



# MENIOTA

AMERICA'S LUXURY FIREPLACE  
FULLVIEW LINEAR DIRECT VENT GAS FIREPLACE HEATER

## Model ML39-PF2

INSTALLATION and OPERATING INSTRUCTIONS MANUAL  
DOCUMENT NO. ML39-PF2-0516



**WARNING:** If the information in this manual is not followed exactly, a fire or explosion may result causing property damage, personal injury or loss of life.

**Do not store or use gasoline or other flammable vapors and liquids in the vicinity of this or any other appliance.**

### WHAT TO DO IF YOU SMELL GAS

- Open windows.
- Do not touch electrical switches.
- Do not try to light any appliance.
- Extinguish any open flame.
- Do not use the phone in your building.
- Immediately call your gas supplier from a neighbor's phone. Follow the gas supplier's instructions.
- If you cannot reach your gas supplier, call the fire department.
- Installation and service must be performed by a qualified installer, service agency or the gas supplier.

**AVERTISSEMENT :** Assurez-vous de bien suivre les instructions donné dans cette notice pour réduire au minimum le risque d'incendie ou pour éviter tout dommage matériel, toute blessure ou la mort.

- Ne pas entreposer ni utiliser d'essence ni d'autres vapeurs ou liquides inflammables dans le voisinage de cet appareil ou de tout autre appareil.
- **QUE FAIRE SI VOUS SENTEZ UNE ODEUR DE GAZ:**
- Ne pas tenter d'allumer d'appareil.
- Ne touchez à aucun interrupteur. Ne pas vous servir des téléphones se trouvant dans le bâtiment où vous vous trouvez.
- Appelez immédiatement votre fournisseur de gaz depuis un voisin. Suivez les instructions du fournisseur.
- Si vous ne pouvez rejoindre le fournisseur de gaz, appelez le service des incendies.
- L'installation et service doit être exécuté par un installateur qualifié, agence de service ou le fournisseur de gaz.

### WARNING

Do NOT use this appliance if any part has been under water. Immediately call a qualified service technician to inspect the appliance and to replace any part of the control system and any gas control, which has been under water.

**INSTALLER:** Leave this manual with the appliance.  
**CONSUMER:** Retain this manual for future reference.

**INSTALLATEUR :** Laissez cette notice avec l'appareil.  
**CONSOMMATEUR :** Conservez cette notice pour consultation ultérieure.

**WARNING**



**HOT GLASS WILL CAUSE BURNS.**  
**DO NOT TOUCH GLASS UNTIL COOLED.**  
**NEVER ALLOW CHILDREN TO TOUCH GLASS.**

**AVERTISSEMENT**



Une surface vitrée chaude peut causer des brûlures.  
Laissez refroidir la surface vitrée avant d'y toucher.  
Ne permettez jamais à un enfant de toucher la surface vitrée.

## **SAFETY AND WARNING INFORMATION**

### **FOR YOUR SAFETY**

A qualified installer, service agency, or the gas supplier must perform installation and service.

Do not store or use gasoline or other flammable vapors and liquids in the vicinity of this or any other appliance.

#### **WARNING**

Do not operate this appliance with the glass removed, cracked or broken. A licensed or qualified person should do replacement of glass.

AVERTISSEMENT. Ne pas utiliser l'appareil si le panneau frontal en verre n'est pas en place, est craqué ou brisé. Confiez le remplacement du panneau à un technicien agréé.

#### **WARNING**

Mendota gas fireplaces are heat producing appliances. Do not burn wood, paper or other materials in this fireplace. This fireplace is designed as a supplement heat source. It is advisable to have an alternative primary heat supply.

In the Commonwealth of Massachusetts:

- Installation must be performed by a licensed plumber or gas fitter;
- A CO detector shall be installed in the room where the appliance is installed.

**WARNING:** Improper installation, adjustment, alteration, service or maintenance can cause injury or property damage. Refer to this manual. For assistance or additional information consult a qualified installer, service agency or the gas supplier.

This appliance may be installed in an aftermarket permanently located, manufactured (mobile) home (USA Only), where not prohibited by local codes.

This appliance is only for use with the type(s) of gas indicated on the rating plate. A conversion kit is supplied with this appliance.

Cet appareil peut être installé dans une maison préfabriquée (mobile) déjà installée à demeure si les règlements locaux le permettent.

Cet appareil doit être utilisé uniquement avec les types de gaz indiqués sur la plaque signalétique. Ne pas l'utiliser avec d'autres gaz sauf si un kit de conversion certifié est installé.

The installation must conform with local codes or, in the absence of local codes, with the current National Fuel Gas Code, ANSI Z223.1 (NFPA 54) or CAN/CGA B149.1 Installation Code.

Installer l'appareil selon les codes ou règlements locaux, ou, en l'absence de tels règlements, selon les Codes d'installation CAN/CGA-B149.

Do not use this appliance if any part has been under water. Immediately call a qualified service technician to inspect the fireplace and to replace any part of the control system and any gas control which has been under water".

«Ne pas se servir de cet appareil s'il a été plongé dans l'eau, complètement ou en partie. Appeler un technicien qualifié pour inspecter l'appareil et remplacer toute partie du système de contrôle et toute commande qui ont été plongés dans l'eau»

**READ and UNDERSTAND** all instructions carefully before starting the appliance. **FAILURE TO FOLLOW** these instructions may result in a possible fire hazard and will void the warranty.

Any safety screen or guard removed for servicing must be replaced before operating this appliance. Tout écran ou protecteur retiré pour permettre l'entretien de l'appareil doit être remis en place avant de mettre l'appareil en marche.

### **THIS UNIT IS NOT FOR USE WITH SOLID FUEL.**

Installation and repair should be **PERFORMED** by a qualified service person. The appliance and venting system should be **INSPECTED** before initial use and at least annually by a professional service person. More frequent cleaning may be required due to excessive lint from carpeting, bedding, material, etc. It is **IMPERATIVE** that the unit's control compartment, burners, and circulating air passageways **ARE KEPT CLEAN** to provide for adequate combustion and ventilation air.

Always **KEEP** the appliance clear and free from combustible materials, gasoline, and other flammable vapors and liquids.

**NEVER OBSTRUCT** the flow of combustion and ventilation air. Keep the front of the appliance **CLEAR** of all obstacles and materials for servicing and proper operation.

Due to high temperature, the appliance should be **LOCATED** out of traffic areas and away from furniture and draperies. En raison des températures élevées, l'appareil devrait être installé dans un endroit où il y a peu de circulation et loin du mobilier et des tentures.

Clothing or flammable material **SHOULD NOT BE PLACED** on or near the appliance. On ne devrait pas placer de vêtements ni d'autres matières inflammables sur l'appareil ni à proximité.

Children and adults should be **ALERTED** to the hazards of high surface temperature and should **STAY AWAY** to avoid burns or clothing ignition. Les enfants et les adultes devraient être informés des dangers que posent les températures de surface élevées et se tenir à distance afin d'éviter des brûlures ou que leurs vêtements ne s'enflamment.

Young children should be **CAREFULLY SUPERVISED** when they are in the same room as the appliance. Toddlers, young children and others may be susceptible to accidental contact burns. A physical barrier is recommended if there are at risk individuals in the house. To restrict access to a fireplace or stove, install an adjustable safety gate to keep toddlers, young children and other at risk individuals out of the room and away from hot surfaces. “Les jeunes enfants devraient être surveillés étroitement lorsqu'ils se trouvent dans la même pièce que l'appareil. Les tout petits, les jeunes enfants ou les adultes peuvent subir des brûlures s'ils viennent en contact avec la surface chaude. Il est recommandé d'installer une barrière physique si des personnes à risques habitent la maison. Pour empêcher l'accès à un foyer ou à un poêle, installez une barrière de sécurité; cette mesure empêchera les tout petits, les jeunes enfants et toute autre personne à risque d'avoir accès à la pièce et aux surfaces chaudes.

These units **MUST** use one of the vent systems described in the Installing Your Fireplace section of the Installers Guide. **NO OTHER** vent systems or components **MAY BE USED**.

This gas fireplace and vent assembly **MUST** be vented directly to the outside and **MUST NEVER** be attached to a chimney serving a separate solid fuel-burning appliance. Each gas appliance **MUST USE** a separate vent system. Common vent systems are **PROHIBITED**.

If the vent-air intake system is disassembled for any reason, reinstall per the instructions provided for the initial installation.

The vent system assembly for this fireplace must be periodically examined by a qualified service agency.

**INSPECT** the external vent cap on regular basis to make sure that no debris is interfering with the airflow. The flow of combustion and ventilation air not to be obstructed

**DO NOT** abuse the glass door by striking the glass, slamming the door shut, etc.

Use only authorized parts and materials obtained from Johnson Gas Appliance Company when replacing defective or damaged glass.

**DO NOT USE** abrasive cleaners on the glass door assembly. **DO NOT ATTEMPT** to clean the glass door when it is hot.

Turn off the gas before servicing this appliance. It is recommended that a qualified service technician perform an appliance check-up annually.

**DO NOT** place furniture or any other combustible household objects within 36 inches of the fireplace front.

# **TABLE OF CONTENTS**

SAFETY AND WARNING INFORMATION.....	2
TABLE OF CONTENTS .....	4
SPECIFIC REQUIREMENTS FOR THE COMMON WEALTH OF MASSACHUSETTS .....	6
ML39 FULL VIEW GAS FIREPLACE DIMENSIONS .....	7
ML39 FEATURES - QUICK REFERENCE INFORMATION .....	8
TECHNICAL SPECIFICATIONS FOR ML39 LINEAR ZC FIREPLACE .....	9
CONGRATULATIONS .....	10
BUILDING PERMIT AND INSTALLATION INSPECTION APPROVAL REQUIREMENTS .....	10
GENERAL APPLIANCE SPECIFICATIONS .....	11
MANTEL CLEARANCES .....	12
CLEARANCES TO COMBUSTIBLES FROM APPLIANCE SURFACES .....	13
CLEARANCE TO SIDE WALL PROJECTIONS.....	13
PLANNING THE INSTALLATION.....	14
ROUGH FRAMING DIMENSIONS.....	15
FRAMING DEPTH AND FINISHING GUIDES.....	16
ADJUSTABLE FRAMING BRACKETS .....	17
FINISHING MATERIALS INSTALLATION .....	17
DECORATIVE FRONTS INFORMATION: .....	18
SAFETY BARRIER.....	20
NON-COMBUSTIBLE FINISHING MATERIALS REQUIREMENTS .....	20
RAISED HEIGHT INSTALLATION OF ML39.....	21
INSTALLATION OF FLAT PANEL TV ON TOP OF ML39 .....	22
ENAMEL PANORAMIC LINER AND FLOOR PLATE INSTALLATION REQUIREMENT .....	23
BACKUP DC POWER INLET PORT INSTALLATION.....	24
GENERAL INFORMATION .....	25
GAS SUPPLY REQUIREMENTS.....	26
GAS PRESSURE REQUIREMENTS.....	27
GAS INPUT RATE VERICATION REQUIREMENTS .....	28
GENERAL INSTALLATION INSTRUCTIONS.....	29
GENERAL FLUE VENTING INSTRUCTIONS.....	30
EXTERIOR VENT LOCATIONS AND RESTRICTIONS.....	31
FLUE VENTING COMPONENTS IDENTIFICATION.....	32
MASTER FLUE VENTING REQUIREMENTS CHART .....	33
APPROVED VENT SYSTEMS QUICK REFERENCE CHART.....	35
MINIMUM RISE HORIZONTAL TERMINATION .....	36
VERTICAL RISE HORIZONTAL TERMINATION.....	37
VERTICAL THROUGH-THE ROOF VENTING .....	39
VERTICAL THROUGH-THE-ROOF VENTING USING FOUR 90° ELBOWS.....	41

ML39 DOOR OPERATION ..... 42

LOCATION OF MASTER SWITCH AND SYNC SWITCH ..... 43

REMOTE CONTROL TRANSMITTER FUNCTIONS ..... 44

REMOTE TRANSMITTER OPERATING INSTRUCTIONS ..... 45

“FIRST TIME” PILOT LIGHTING INSTRUCTIONS..... 47

IPI/STANDING PILOT SYSTEM INFORMATION..... 48

OPTIONAL BURNER MEDIA KITS ..... 49

FOREST OAK TWIG SET INSTALLATION INSTRUCTIONS ..... 51

DRIFTWOOD LOG KIT INSTALLATION INSTRUCTIONS..... 56

FLAME APPEARANCE ADJUSTMENT ..... 61

INSTALLATION CHECK OFF LIST ..... 62

LIGHTING CHECK OFF LIST..... 62

TROUBLE SHOOTING THE ML39 FIREPLACE & MAINTENANCE INFORMATION..... 63

MAINTENANCE..... 64

NATURAL TO LP GAS CONVERSION ..... 66

LPG PRESSURE REGULATOR CONVERSION INSTRUCTIONS..... 68

LP GAS PRESSURE REQUIREMENTS ..... 69

CHECKING FOR NORMAL BURNER IGNITION CHARACTERISTICS ..... 70

ML39 VALVE ASSEMBLY REPLACEMENT PARTS ..... 71

ML39 GAS IGNITION SYSTEM WIRING DIAGRAM..... 72

GLASS FRAME ASSEMBLY REPAIR AND REPLACEMENT ..... 73

LISTING LABEL INFORMATION ..... 74

MENDOTA WARRANTY QUALIFICATION & SERVICE REFERENCE FORM ..... 77

MENDOTA EXTENDED PROTECTION AND LIMITED WARRANTY ..... 79

## **SPECIFIC REQUIREMENTS FOR THE COMMON WEALTH OF MASSACHUSETTS**

The information in this section applies to all installations performed in the Commonwealth of Massachusetts only. For all side wall horizontally vented gas fueled equipment installed in every dwelling, building or structure used in whole or in part for residential purposes and where the side wall exhaust vent termination is less than seven (7) feet above grade, the following requirements shall be satisfied:

If there is no carbon monoxide detector with an alarm already installed in compliance with the most current edition of NFPA 720, NFPA 70 and the Massachusetts State Building code in the residential unit served by the side wall horizontally vented gas fueled equipment, a battery operated carbon monoxide detector with an alarm shall be installed in compliance with the most current edition of NFPA 720, NFPA 70 and the Massachusetts State Building Code.

In addition to the above requirements, if there is not one already present, a carbon monoxide detector with an alarm and a battery backup shall be installed and located in accordance with the installation requirements supplied with the detector on the floor level where the gas equipment is installed. The carbon monoxide detector with an alarm shall comply with 527 CMR, ANSI/UL 2034 Standards or CSA 6.19 and the most current edition of NFPA 720. In the event that the requirements of this subdivision cannot be met at the time of the completion of the installation of the equipment, the installer shall have a period of thirty (30) days to comply with this requirement; provided, however, that during said thirty (30) day period, a battery operated carbon monoxide detector with an alarm shall be installed in compliance with the most current edition of NFPA 720, NFPA 70 and the Massachusetts State Building Code. In the event that the side wall horizontally vented gas fueled equipment is installed in a crawl space or an attic, the carbon monoxide detector may be installed on the next adjacent habitable floor level. Such detector may be a battery operated carbon monoxide detector with an alarm and shall be installed in compliance with the most current edition of NFPA 720, NFPA 70 and the Massachusetts State Building Code.

A metal or plastic identification plate shall be permanently mounted to the exterior of the building at a minimum height of eight (8) feet above grade directly in line with the exhaust vent terminal for the horizontally vented gas fueled heating appliance or equipment. The sign shall read, in print size no less than one-half (1/2) inch in size, "GAS VENT DIRECTLY BELOW, KEEP CLEAR OF ALL OBSTRUCTIONS"

A final inspection by the state or local gas inspector of the side wall horizontally vented equipment shall not be performed until proof is provided that the state or local electrical inspector having jurisdiction has granted a permit for installation of carbon monoxide detectors and alarms as required above.

(b) EXEMPTIONS: The following equipment is exempt from 248 CMR 5.08(2) (a) 1 through 4:

1. The equipment listed in Chapter 10 entitled "Equipment Not Required To Be Vented" in the most current edition of NFPA 54 as adopted by the Board; and

2. Product Approved side wall horizontally vented gas fueled equipment installed in a room or structure separate from the dwelling, building or structure used in whole or in part for residential purposes.

(c) When the manufacturer of Product Approved side wall horizontally vented gas equipment provides a venting system design or venting system components with the equipment, the instructions for installation of the equipment and the venting system shall include:

1. A complete parts list for the venting system design or venting system; and
2. Detailed instructions for the installation of the venting system design or the venting system components.

(d) When the manufacturer of a Product Approved side wall horizontally vented gas fueled equipment does not provide the parts for venting the flue gases, but identifies "special venting systems", the following shall be satisfied:

1. The referenced "special venting system" instructions shall be included with the appliance or equipment installation instructions; and

2. The "special venting systems" shall be Product Approved by the Board, and the instructions for that system shall include a parts list and detailed installation instructions.

(e) A copy of all installation instructions for all Product Approved side wall horizontally vented gas fueled equipment, all venting instructions, all parts lists for venting instructions, and/or all venting design instructions shall remain with the appliance or equipment at the completion of the installation.

# ML39 FULL VIEW GAS FIREPLACE DIMENSIONS

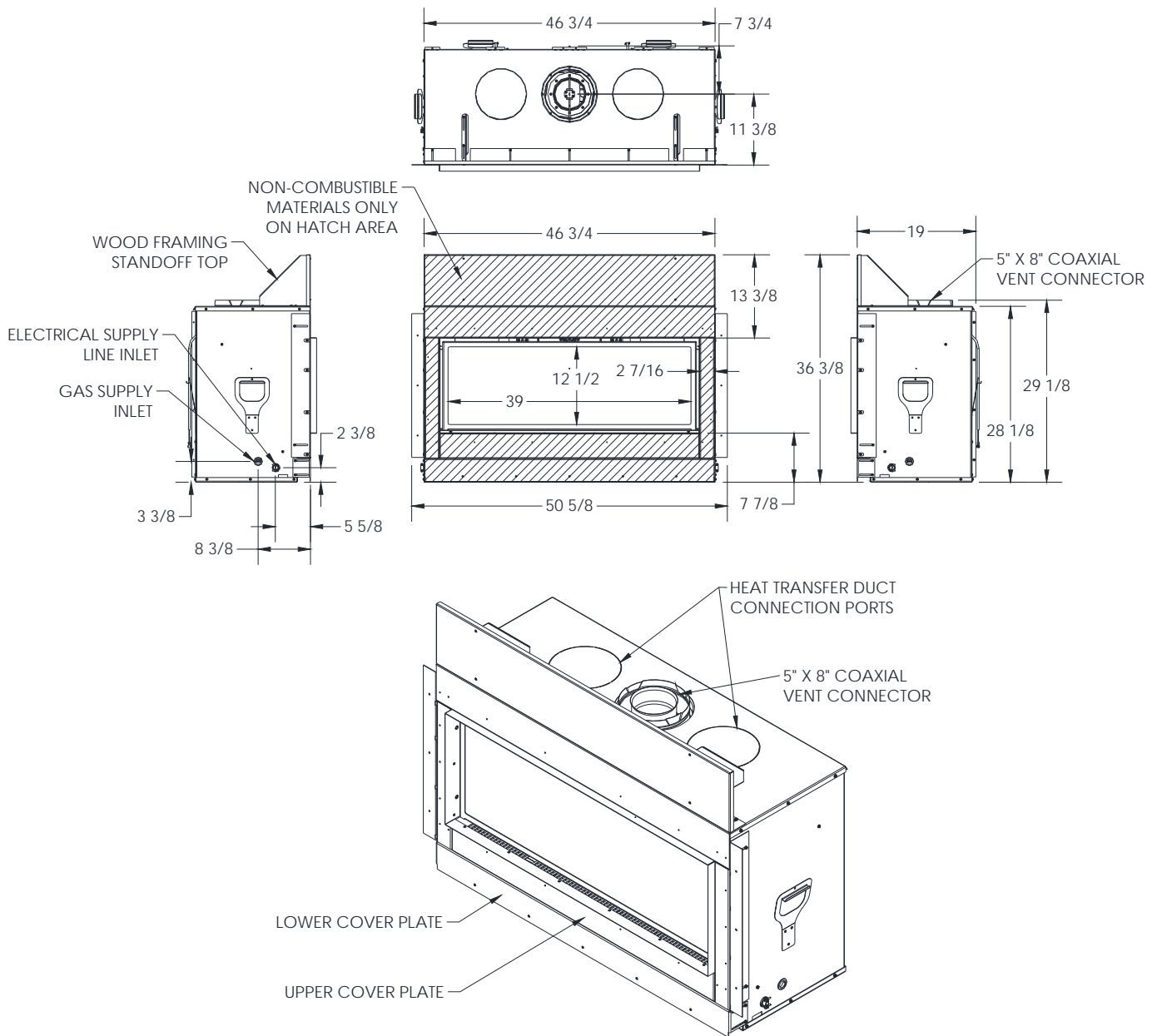

**Removable Cover Plate for Plumbing & Electrical Access before unit is placed inside framed cavity. Replace Lower Cover Plate before sliding unit into framed cavity.**

## **ML39 FEATURES - QUICK REFERENCE INFORMATION**

**Certification And Listing:** Certified under ANSI Z21.88 (2014) • CSA 2.23 (2014) "Vented Gas Fireplace Heater " not for use with solid fuel. **Not to be used as primary heat source.**

**Efficiency Ratings:** P.4 Fireplace Efficiency: 77.3%

**External Dimensions:** 48-1/4" Wide X 37" High X 19-1/2" Deep

**Glass Size:** NeoCeram Glass with non-reflective coating. Visible Glass measures 39" X 12-1/2". Visible Glass Area equals 487.5 in<sup>2</sup>. Actual Glass size is 40-1/8" X 13-5/8".

**Minimum Fireplace Framing Dimensions Requirement:** 48-1/4 Wide X 37" High X 19-1/2" Deep

**Framing Materials Requirement:** Minimum 2X4 Lumber

**Hearth Protection Pad:** **NOT REQUIRED:** Glass bottom edge is raised 9" within appliance body.

**Electrical Supply Requirement:** 120 VAC, 5 Amps, Un-switched, Junction Box provided inside appliance.

**Vent System Requirements:** 5"x8" Coaxial Rigid Vent System. MINIMUM INITIAL VERTICAL RISE REQUIRED IS 18" for Natural Gas and 24" for LP Gas. Maximum Horizontal Vent Length with the Minimum Vertical Starter Section equals 6". Maximum Horizontal Vent run with 4 feet Vertical starter section connection equals 32 feet for NG and 27 feet for LPG.. Maximum Vertical vent run equals 42 feet.

**Mantel Allowance:** 8" Deep Mantel at 12" Above Top Convection Opening .Use the Approved Mantel Profile Chart.

**Vent Damper Adjustment Available:** A single Disc Damper is available for exhaust flow adjustments.

**Controls:** IPI Electronic Ignition System with AC Primary Power and DC Backup Power. Remote Control included. Accent Light operates on AC Power only.

**Blower System:** Optional 210 CFM Dual Blower System. 120VAC, 2 Amps. Dedicated Hot Power only. No switches, Fan Speed Controls or Light Dimmers are allowed in the same AC supply circuit. Optional fans are controlled using remote control.

**Accent Light System:** Dual Accent Light System Included. Light can be turned on or off and dimmed from remote control.

**Burner System:** Single Ceramic Plaque Array burner.

**Burner Shutter System:** Manually controllable internal rotary Burner air shutter.

**Burner Media Options:** Must install one burner media. Driftwood Logs set with Natural Rocks, Twig Set with coals, Natural Rock Set, Black Shades Rock Set, Diamond Clear Glass Pieces, Diamond Shape Black Glass Pieces, Round Clear Glass, and Round Black Glass. Multiple Media types may be combined together..

**Firebox Inner Lining Panels:** Black Enamel, Midnight Metallic Enamel, Metallic Mocha Enamel, Metallic Silver Enamel and Copper Enamel Panoramic options available. Each Firebox Panoramic Liner is supplied with matching Firebox Floor Panel. ***One Firebox Inner Liner Kit must be installed before any use.***

**Natural Gas Information:** Factory equipped for Natural Gas. 5"WC Minimum inlet pressure required. For NG applications, Burner Orifice Size is 1/8".

**LPG Information:** LP conversion kit #HA-96-00023 is an available option. 11"WC Minimum inlet pressure required.

**NOTE:** This installation must conform to local codes. In the absence of local codes, you must comply with the **National Fuel Gas Code, ANSI Z223.1-latest edition** in the U.S.A. and the Natural Gas and Propane Installation Code, **CSA B149 Installation Codes** in Canada.

CAUTION  
THESE INSTRUCTIONS ARE TO  
REMAIN WITH THE HOMEOWNER.

This appliance may be installed in an after-market, permanently located, manufactured home (USA only) or mobile home, where not prohibited by local codes.  
This appliance is only for use with the type(s) of gas indicated on the rating plate.



# TECHNICAL SPECIFICATIONS FOR ML39 LINEAR ZC FIREPLACE

	High Fire - Adjustable to -	Low Fire
BTUH. (MODEL ML39) NAT. GAS	34,250	23,000
BTUH. (MODEL ML39) LP GAS	34,250	28,000

**NOTE: LPG CONVERSION KIT, #HA-96-00023 MUST BE PURCHASED SEPARATELY TO CONVERT TO BURN LPG IN THIS FIREPLACE.**

MAIN ORIFICE: [0-2000ft (610 m)]: #33 NG - #50 LP  
[2000-4500ft (610-1370 m)]: #34 NG - #51 LP

OVERALL EFFICIENCY: [P.4: 77.3%]  
CO-AXIAL DIRECT VENT FLUE: 5" INNER, 8" OUTER, RIGID  
TOTAL WEIGHT: 300 POUNDS  
SAFETY: AGA/CECERTIFIED IPI AUTO ELECTRONIC IGNITION SYSTEM  
ACTIVATED WITH REMOTE CONTROL.



## **APPLIANCE CERTIFICATION AND TESTING AGENCY**

INTERTEK TESTING SERVICES, ICBO#AA647-4

Certified under ANSI Z21.88 (2014) • CSA 2.23 (2014) "Vented Gas Fireplace " not for use with solid fuel. Approved for bedroom installations and mobile homes. UL307B approved for "mobile homes, after first sale of home, not for recreational vehicles."

**GAS REQUIREMENTS SUPPLY PRESSURE:** GAS INLET: 1/2" N.P.T.

NAT. GAS: **7" W.C.** (5" W.C. MIN., 11" W.C. MAX.)

L.P. GAS: **11.0" W.C.** (12" W.C. MIN., 13" W.C. MAX.)

**ELECTRICAL REQUIREMENTS:** 115 VOLT, LESS THAN 1.5 amps (6V DC BACKUP POWER SUPPLY)

**APPROVED VENT SYSTEMS:** DURAVENT, SELKIRK, AMERIVENT, SECURITY, BDM

## **MINIMUM CLEARANCES TO COMBUSTIBLE CONSTRUCTION**

UNIT TO FLOOR	0in. (0mm)	GLASS EDGE TO ADJACENT SIDEWALL	16in. (406 mm)
UNIT TO ENCLOSURE SIDEWALL	1/2in. (13mm)	VENT PIPE TOP TO COMBUSTIBLES	3in. (76mm)
UNIT TO ENCLOSURE BACK WALL	1/2in. (13mm)	VENT PIPE SIDES TO COMBUSTIBLES	1in. (25mm)
UNIT BOTTOM TO ENCLOSURE CEILING	44-3/16in. (1122 mm)	VENT PIPE BOTTOM TO COMBUSTIBLES	1in. (25mm)
UNIT BOTTOM TO ROOM CEILING	60 in. (1524 mm)	8" MANTLE ABOVE DISCHARGE AIR OPENING	12 in. (304 mm)

## **MINIMUM COMBUSTIBLE ROUGH FRAMING DIMENSIONS**

WIDTH = 48-1/4" (138 cm)      HEIGHT = 37" (99.6 cm)      DEPTH = 19-1/2" (49.5 cm)

THIS FIREPLACE INCLUDES A SEALED COMBUSTION SYSTEM, NEO-CERAM GLASS, ELECTRONIC IGNITION SYSTEM, AGA CERTIFIED SAFETY SYSTEM, DUAL ACCENT LIGHTS and REMOTE CONTROL.

OPTIONS: BLACK, VINTAGE IRON, SWEDISH NICKEL, ANTIQUE GOLD, ANTIQUE COPPER GRACE, TRADITIONS AND WILLOW BROOK TRIM KITS. Burner Media Options include Driftwood, Twig Set and many colored and clear glass bead burner media, Natural Rocks Kit.

**WARNING: Do not operate this appliance with the glass removed, cracked or broken. A licensed or qualified person should do replacement of glass.**

**Derating at altitudes above 2000 feet:** Installation of this appliance at altitudes above 2000 feet requires the gas input to be derated by reducing the main burner orifice size. For NG and LPG applications, the main burner orifice size for altitudes above 2000 feet shall be #34 and #51, respectively. For NG and LPG gas, input rate for installation above 2000 feet shall be 32,500 Btu/Hr. and 33,800 Btu/Hr. respectively.

## **CONGRATULATIONS**

You are the owner of a world-class modern gas direct vent sealed combustion fireplace.

This elegant, highly efficient Fireplace will be a constant source of comfort and fascination. It will be the focal point of beauty and interest in your home.

This Mendota Gas Fireplace is an appliance incorporating modern aesthetics of fire viewing. Of particular interest is the low fuel consumption and brilliant fire viewing afforded by the latest technology combustion system.

Carefully read the following instructions prior to actual installation. Proper Mendota Gas Fireplace installation and operation will give you years of safe, trouble free comfort and enjoyment.

If you have any questions regarding installation or operation of your Mendota Fireplace please contact your local dealer.

...CAUTION...

Due to high temperatures, the Fireplace should be located out of traffic and away from furniture and draperies. Children and adults should be alerted to the hazards of high surface temperature and should stay away to avoid burns or clothing ignition. Young children should be carefully supervised when they are in the same room as the Mendota Gas Fireplace.

Clothing or other flammable material should not be placed on or near the Fireplace.

Any safety screen or guard removed for servicing an appliance must be replaced prior to operating this appliance.

The Mendota Gas Fireplace, although certified and listed as a Decorative Gas Appliance, operates at 70% Steady State Efficiency (62% Fireplace Efficiency, P.4) and can be a source of supplemental heat with heat output equal to 24,000 Btu/Hr..

Installation, repair and any adjustments to logs or burner must be done by a qualified service person. The appliance should be inspected before use and at least annually by a professional service person. More frequent cleaning may be required due to excessive lint from carpeting, bedding material, carbon build-up, etc. It is imperative that control compartments, burners and circulating air passageways of the appliance be kept clean. The burner and pilot flames and logs should be visually checked periodically.

DO NOT use this appliance if any part has been under water or exposed to moisture corrosion. Immediately call a qualified service technician to inspect the Fireplace and replace any part of the control system and any gas control, which has been under water. DO NOT use this fireplace if the burner does not light immediately. Turn unit off and call Mendota approved service person if there is any delay in burner light off.

It is Johnson Gas Appliance Company's policy that no responsibility is assumed by the Company or by any of its employees or representatives for any damages caused by an inoperable, inadequate, or unsafe condition which is the result, either directly or indirectly, of any improper operation, installation or servicing procedures.

## **BUILDING PERMIT AND INSTALLATION INSPECTION APPROVAL REQUIREMENTS**

All installations of Mendota Fireplaces and Inserts must comply with all the requirements stated in this Installation and Operating Instructions Manual. The Dealer and/or installer must also obtain all required Building Permits and Inspection Approval from the local building inspection department or the local body having jurisdiction. In order to validate warranty coverage, Mendota may require facsimile copies of the Building Permit and Inspection Approval forms. Failure to provide adequate proof that the installation conforms to all local requirements and the requirements stated in the Installation and Operating Instructions Manual will void all applicable warranty.

INSTALLER: THESE INSTRUCTIONS ARE TO REMAIN WITH HOMEOWNER.

**HIGH ALTITUDE INSTALLATION INFORMATION:** Prior to installing at altitudes higher than 7500, please contact the Mendota technical service department for specific venting requirements and venting restrictions.

# GENERAL APPLIANCE SPECIFICATIONS

**High Altitude Installation Information:** Prior to installing at altitudes higher than 7500, please contact the Mendota technical service department for specific venting requirements and venting restrictions.

MINIMUM ROUGH FRAMING DIMENSIONS		
WIDTH (IN)	HEIGHT (IN)	DEPTH (IN)
48-1/4	37"	19-1/2

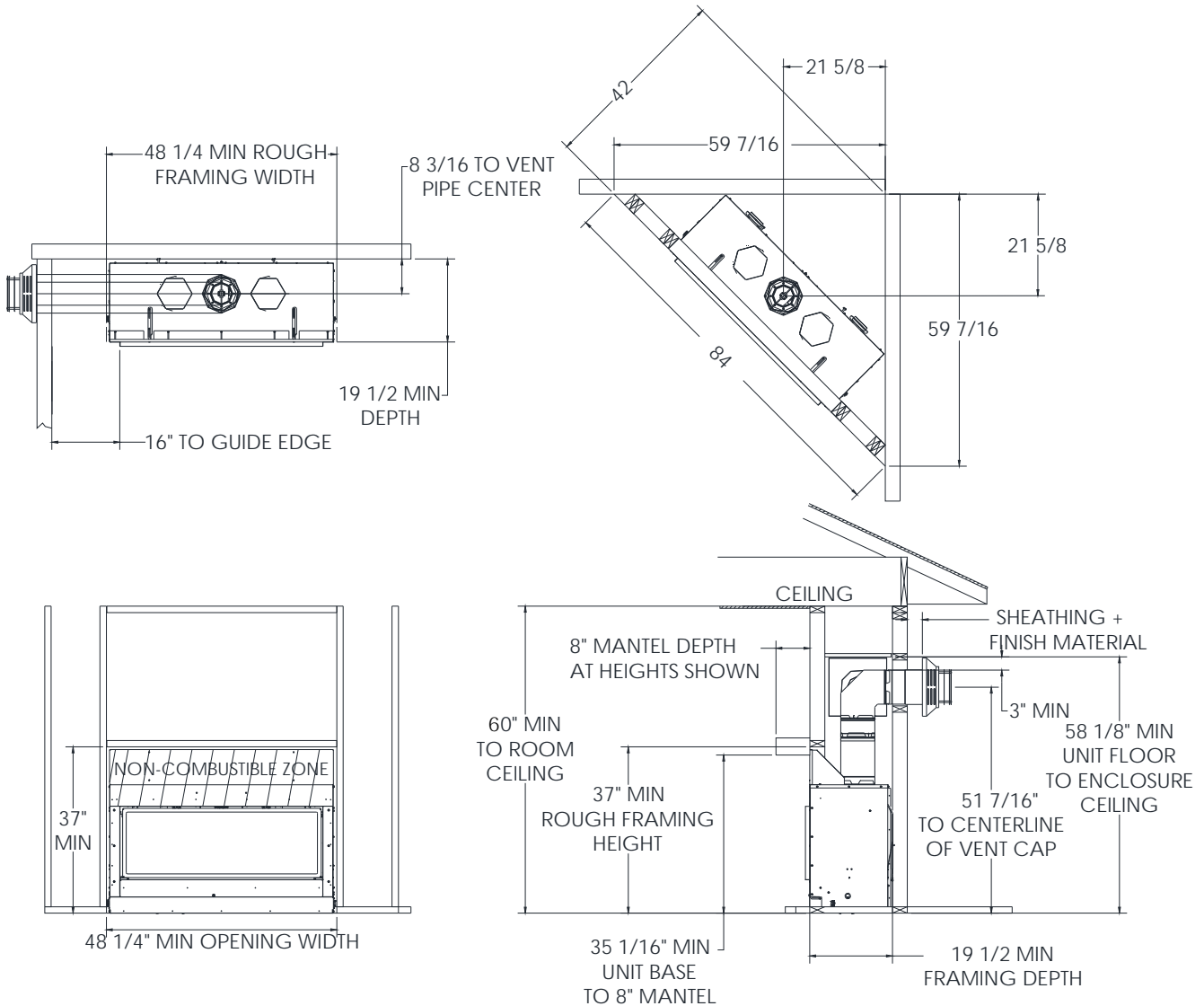

# MANTEL CLEARANCES

Mantel Clearances for this fireplace may be measured from the top of the convection air opening or the floor level of this fireplace.

The location that is referenced normally to measure mantel clearances is the Top of the Convection Air Opening. For ease, however, measure up from the floor level of this fireplace. The chart and diagram, in this page, provide all the reference dimensional information necessary in determining the distance a combustible mantel may protrude out from the face surface of this fireplace. The Chart, at right, shows the Distance from Fireplace Face the combustible mantel may protrude outward at a Distance up From Floor Level of this Fireplace.

If you prefer to take measurements from the top of the convection air opening, note that the top of the convection air opening is 23 inches up from the floor level of this fireplace.

**WARNING:** Make proper use of this chart. Do not compromise the specifications contained in this chart. Failure to adhere to proper clearances required to combustibles may cause spontaneous combustion of the mantel and may result in a fire causing property damage, personal injury or loss of life.

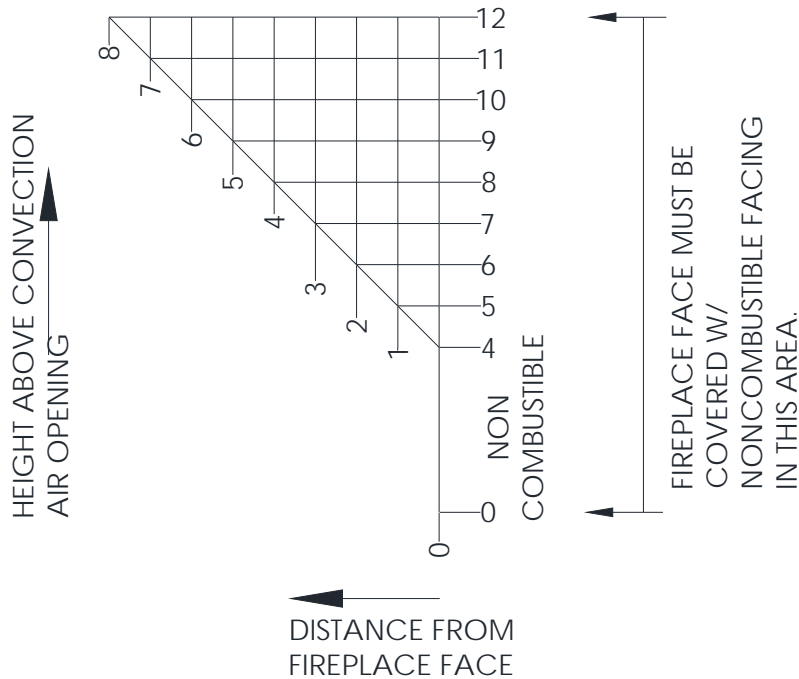

APPROVED MANTEL PROFILE

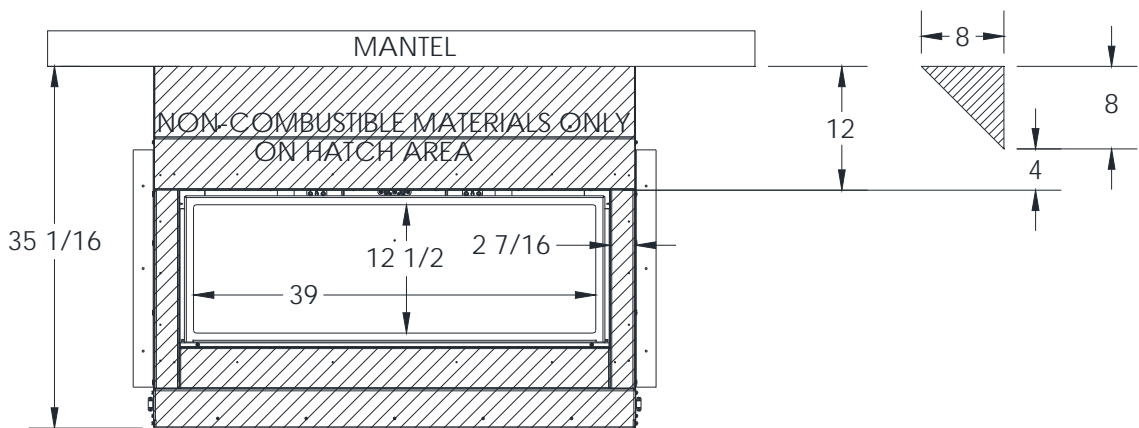

## CLEARANCES TO COMBUSTIBLES FROM APPLIANCE SURFACES

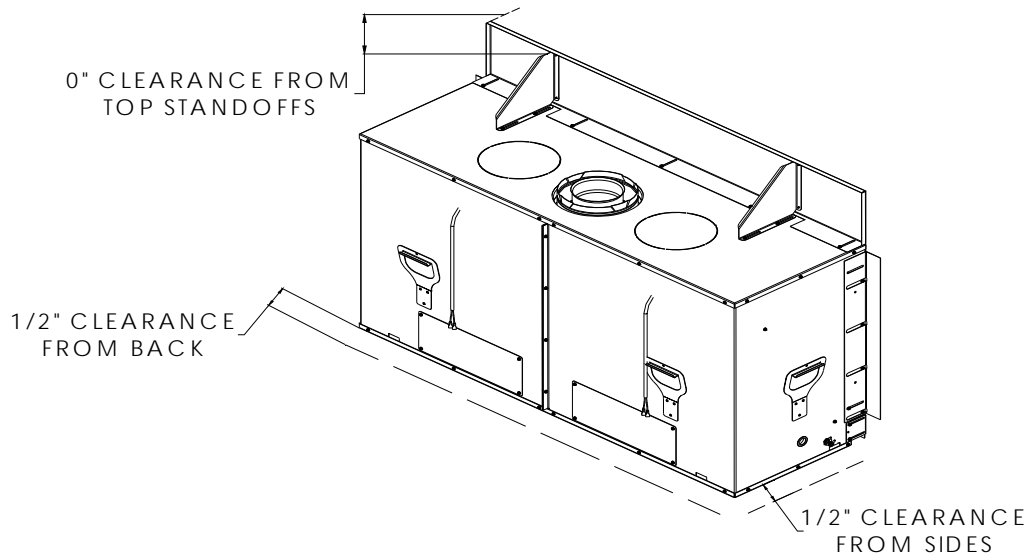

## CLEARANCE TO SIDE WALL PROJECTIONS

Any side wall adjacent to Left or Right side of this appliance protruding out more 16" in from of the front surface of the visible glass door and if perpendicular to the front surface of the glass door must be located a minimum of 16" from the side edge of the visible glass door.

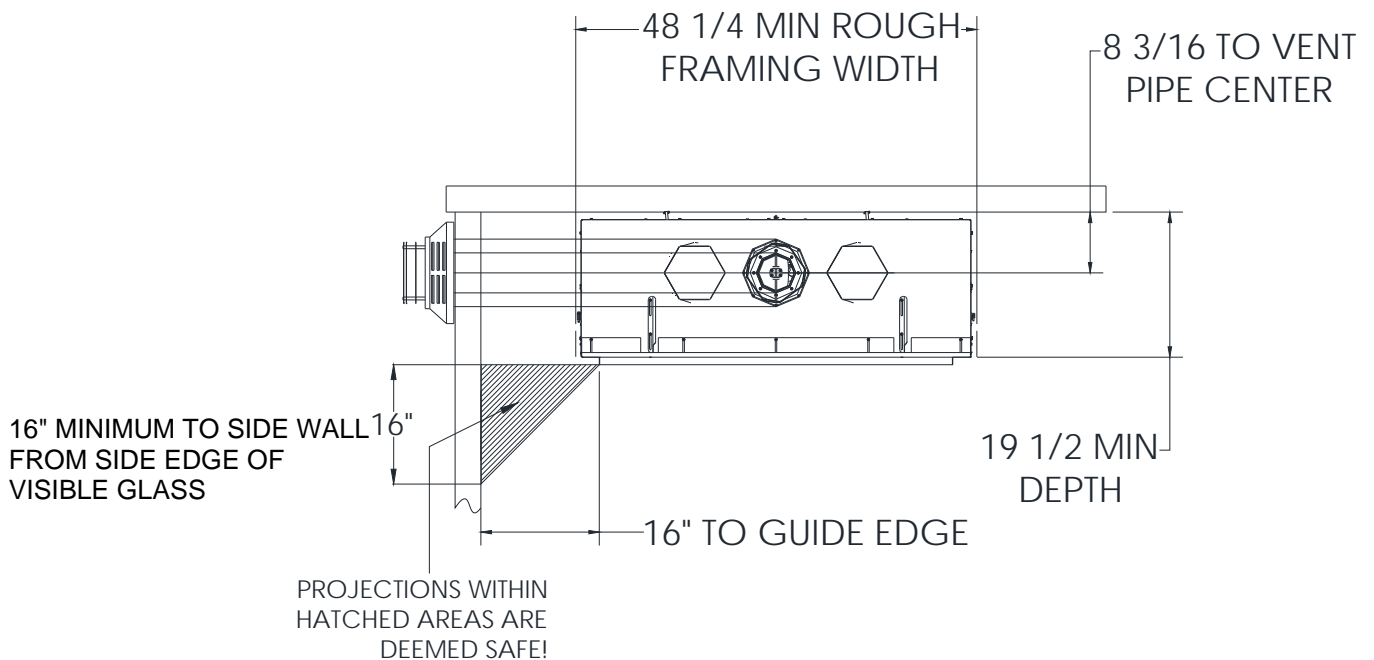

## PLANNING THE INSTALLATION

When planning on appliance installation, it is necessary to determine the following information before installing:

- Where the appliance is to be installed.
- The vent system configuration to be used.
- Gas supply piping.
- Electrical Wiring.
- Framing and finishing details.
- Hearth Protection Pad Requirements.
- Whether accessories such as a wall switch, remote control, and ceiling fan are desired.

### Selecting Appliance Location

When selecting a location for your appliance, it is important to consider the required clearances to adjacent side walls.

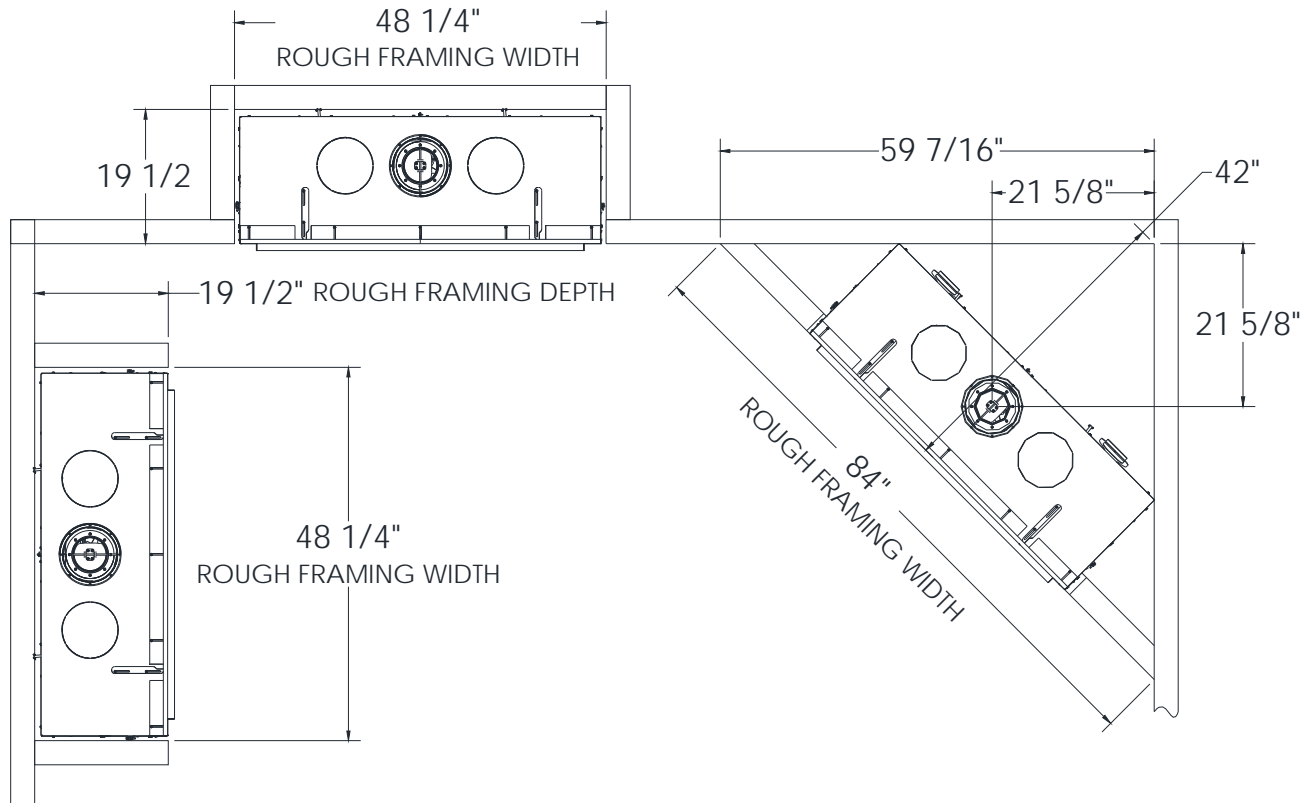

#### WARNING

#### FIRE RISK- ODOR RISK

- Do NOT install this fireplace directly on carpeting, vinyl or any combustible material other than wood. Construct chase to all clearance specifications in manual.
- Locate and install appliance to all clearance specifications in manual.
- **ODOR RISK:** DO NOT INSTALL ANY CEMENT BOARDS OF OTHER MATERIALS THAT CONTAIN POLYMER BASED FIBERS OR OTHER POLYMER MATERIALS.

## ROUGH FRAMING DIMENSIONS

The Rough Framing Dimensions must be maintained to allow this fireplace to slide into the framing cavity.

If the fireplace is to be recessed in a cavity deeper than 19-1/2", all framing and finishing materials protruding past the front face of this fireplace must be of the NON-COMBUSTIBLE variety.

Minimum Rough Framing Dimensions		
	DESCRIPTION	DIMENSION (INCHES)
A	Width	48-1/4
B	Height	37"
C	Depth	19-1/2" (19" Granite/Marble Facing)
D	Vent opening height	10-3/4"
E	Vent opening width	10-3/4"

### Constructing the Appliance Chase

A chase is a vertical box-like structure built to enclose this fireplace and its vent system. Vertical vents that run on the outside of a building may be, but are not required to be, installed inside a chase.

Construction of the chase may vary with the type of building. These instructions are not substitutes for the requirements of local building codes. Local building codes **MUST** be adhered to.

Chases should be constructed in the manner of all outside walls of the home to prevent cold air drafting problems. The chase should not break the outside building envelope in any manner.

Wall, ceiling, base plate and cantilever floor of the chase should be insulated. Vapor and air infiltration barriers should be installed in the chase as per regional codes for the rest of the home. Additionally, in regions where cold air infiltration may be an issue, the inside surfaces of the chase may be sheet rocked and taped for maximum air tightness.

To further prevent drafts, the fire stops should be caulked with high temperature caulk to seal the gaps. Gas line holes and other openings should be caulked with high temp caulk or stuffed with un-faced insulation. If the appliance is being installed on a cement slab, a layer of plywood may be placed underneath this fireplace to prevent conducting cold up into the room.

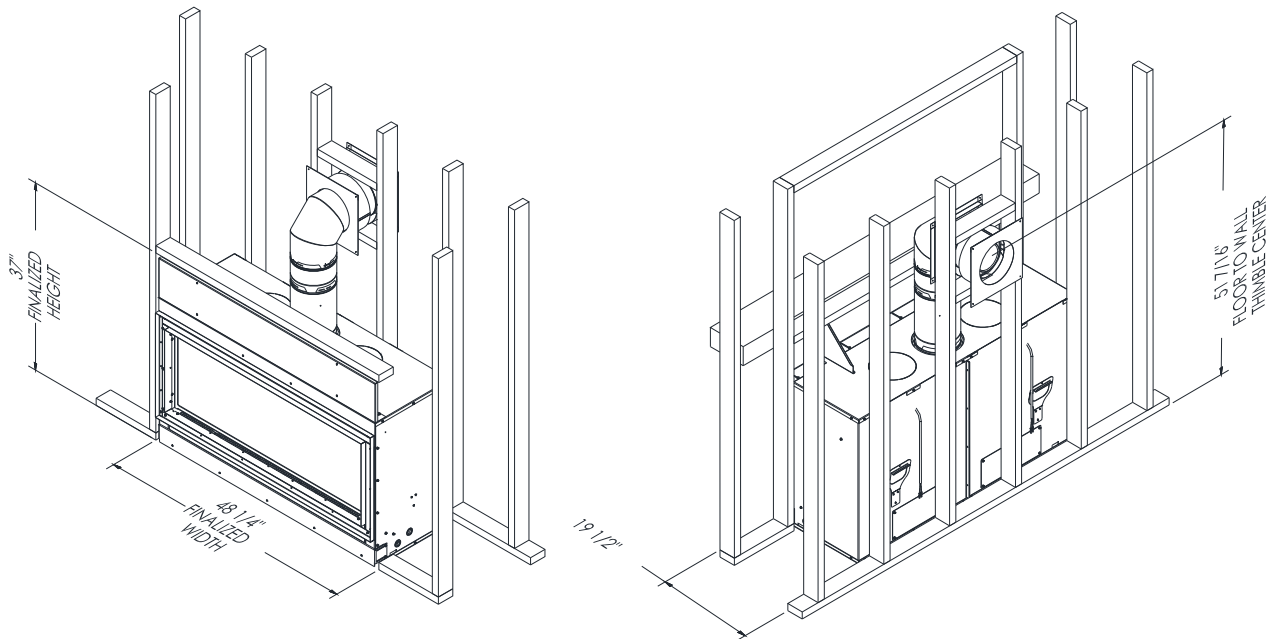

## **FRAMING DEPTH and FINISHING GUIDES**

The general framing depth for this fireplace is 19-1/2 inches. See details about using the Adjustable Framing Bracket, below for flexibility for framing depths.

For installing solid Granite or Marble slabs as fascia material, reduce the framing depth by 1/2" then install 1/2" thick drywall on the framing studs so that the drywall is flush with the front face of this fireplace. Install the Granite or Marble slab so that it adheres to the face of the fireplace and the drywall.

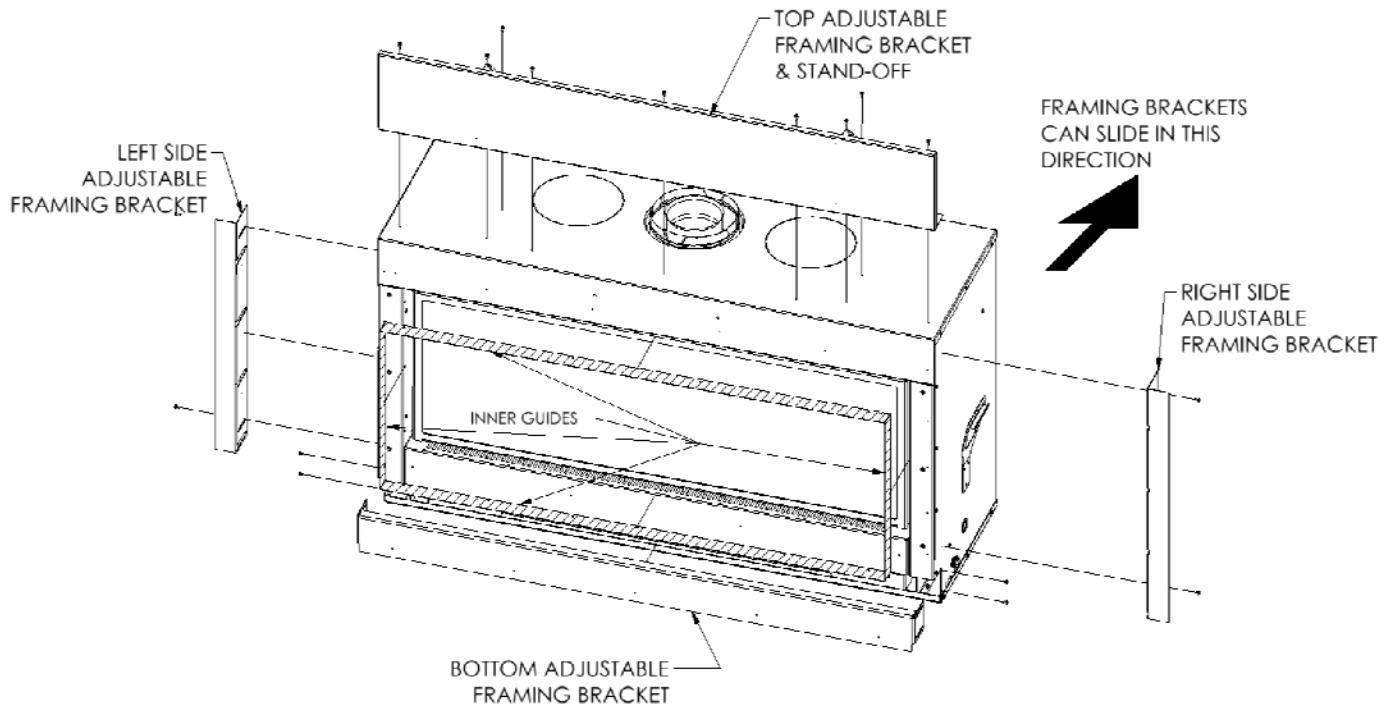

**Adjustable Framing Brackets (Sides, Top and Bottom):** Defined as Metal Brackets which are secured to the front outer perimeter of the ML-39 body and have adjustable slots to move inward to reduce the rough framing depth by the thickness of the Finishing Material base Substrate. To adjust, loosen securing screws and slide brackets backwards.

**Inner Guide:** Defined as the flat metal guides supplied with the ML-39 which are located at the outer perimeter of the convection air gap around the glass frame. These act as temporary guides and are to be used to position the finishing material's edges adjacent to the top, sides and bottom convection air gap around the glass frame. Use the Inner Guide if you installing only the Traditions or Willowbrook Front or if you wish to install the Grace Front on top of your final finishing material that is less than 2.00 inches thick.

**Outer Guide** (not shown): Defined as the bent metal guides which are designed to be used as the inner edge of final finishing material bordering the outer edge of the Grace Decorative Front. The Outer Guide should be used if you desire the final finishing material thickness to be deeper than 2" thick or if you wish the Grace Decorative Front to be recessed closer to the viewing glass surface.

**Finishing Material base Substrate:** Defined as any non-combustible materials (which are required in the non-combustible materials only allowed zones of this fireplace) or drywall boards (normally used in combustible material allowed zones) which is secured to the rough frame members and act as the inner substrate that the final finishing material is adhered to.

**Final Finishing Material:** Defined as any non-combustible finishing material such as polished granite or marble, ceramic tiles, faux rock, brick or others.



## **ADJUSTABLE FRAMING BRACKETS**

The ML-39 model is factory equipped with Top, Sides and Bottom adjustable framing brackets. These parts can slide backwards the thickness of the ***Finishing Material base substrate*** such as Durock, Hardibacker (in non-combustible zones) or Drywall board (in combustible material allowed zones). The framing depth shall be reduced by the thickness of the Finishing Material base.

### **What is the core purpose and end benefit of the adjustable/sliding Top, Sides and Bottom Framing Brackets?**

Adjusting the adjustable Top, Sides and Bottom framing brackets backwards equal to the thickness of the ***Finishing Material base Substrate*** results in only the thickness of the final finishing material protruding out from the face of the ML-39 unit. Doing this allows you to remove and discard the Inner Guides if installing tiles with metallic tile edging strips or if installing the Grace Front on top of the Final Finish Material. The Grace mounting brackets allow in/out adjustment for final finish material thickness of up to 2 inches.

### **How is the Rough Framing Depth of ML-39 affected if you adjust the Outer Framing Brackets?**

1. The nominal rough framing depth for the ML-39 is 19-1/2". You may slide the Outer Framing Bracket backwards to reduce the rough framing depth by the same amount. Example: If you slide the Outer Framing Brackets backwards 1/2", then the required rough framing depth will be  $19\text{-}1/2" - 1/2" = 19"$ .

### **What do these adjustable Outer Framing Brackets parts affect?**

1. The adjustable outer edge metal parts eliminate the need for the Minimum 1" thick finishing material thickness.
2. If you reposition the Outer Adjustable Framing Brackets, you should remove and discard the Inner Guides. Instead, use metallic tile edging strips, available at home improvement stores in various shapes and colors. Never use polymeric (plastic) tile edging strips.

## **FINISHING MATERIALS INSTALLATION**

All finishing materials that surround this fireplace's rectangle profile must extend out from the face surface of this fireplace 1 inch if the 19-1/2" framing depth is used and the Inner or Outer Finishing Guides are utilized. **A MAXIMUM THICKNESS OF 2" OF FINISHING MATERIAL IS ALLOWED OVER THE FACE OF THE UNIT WHEN USING THE INNER GUIDES AND INSTALLING A GRACE FRONT!** If you wish to install finishing materials in thickness greater than 2" with the Grace Front, use outer guides.

### **Tiles and Faux Rock**

If installing Tiles or Faux Rock, first install a 1/2" thick (minimum) Cement Board (Hardibacker or Durock Brand) over the face of the fireplace and framing members. Follow by applying ThinSet mortar (no polymer additives) using 1/4" square notched trowel on the cement board surface. Finally, install tile to reach a finish material depth of 1 inch.

**WARNING OF ODOR RISK:** Cement Boards used shall not contain any polymer based fibers or polymer materials. ThinSet mortar with polymer additives is not allowed. If in doubt, use RTV 500°F rated high temperature silicone to adhere tile, granite or marble to the face of unit. Always apply the silicone in 1/8" wide beads in spline shape vertical lines only. Allow at least 24 hours to for the silicone to cure before firing this fireplace.

### **Marble and Granite Slabs**

If installing Marble or Granite slabs as fascia materials, specify that the inner edges that will be adjacent to the Glass Door are polished. Rough Framing should be created at 19" depth with the front surface of this fireplace protruding out 1/2" from the framing surface.

Install 1/2" thick drywall on framing members so that its outer surface is flush with the front face of this fireplace. Attach Marble or Granite slabs to face of unit and to drywall surface using adhesive that does not off gas when hot. Mendota recommends the use of Copper RTV Silicone as the adhesive applied in thin 1/8 beads of spline shapes. NEVER place large globs of any adhesive or Copper RTV Silicone between two faces. Doing so will cause odor issue for long periods of time after installation is completed.

In the area defined as "NONCOMBUSTIBLE ZONE", only NONCOMBUSTIBLE MATERIALS ARE ALLOWED. DO NOT INSTALL DRYWALL OVER THE NONCOMBUSTIBLE ZONE.

### **WARNING OF ODOR RISK**

**Cement Boards used shall NOT contain any polymer based fibers or polymer materials. ThinSet mortar used shall not contain any polymer additives.**

## **DECORATIVE FRONTS INFORMATION:**

### **Traditions Front Only:**

The Traditions Front is approximately the overall size of the viewing glass frame. This Front mounts using steel barrel nuts on the outer sides of the viewing glass frame. The bracket attached to the Traditions Frame allows you to pull the Traditions outward in incremental steps up to 1", maximum. The Traditions Front can be close to the glass frame or away from the glass frame. This front comes with a screen and is a conforming safety barrier.

For the Traditions Front, use the inner guides or use your selection of Metallic tile edging.



### **Willowbrook Front Only:**

The Willowbrook Front is, approximately, the overall size of the viewing glass frame. This Front mounts using steel barrel nuts on the outer sides of the viewing glass frame. The bracket attached to the Willowbrook Frame allows you to pull the Willowbrook outward in incremental steps up to 1", maximum. This front comes with a screen and is a conforming safety barrier.

For the Willowbrook Front, use the inner guides or use your selection of Metallic tile edging.



**Grace Front Only:**

The Grace Front's inner edges start outside the convection air gaps around the viewing glass frame. This Front is mounted using steel spacers and screws on the outer sides of the convection air gap on the sides of the viewing glass frame. The bracket attached to the Grace Frame allows you to pull the Grace outward in incremental steps up to 2", maximum. The Grace Front can be mounted close to the steel face of this fireplace if the Outer Guides are used and are applicable in the installation plan. Else, if Final Finishing material is desired behind the Grace Front, use the Inner Guides and adjust the rough framing depth and the Outer Adjustable Framing Brackets. With Final Finishing Material mounted behind the Grace by using the inner guides, the Grace can be mounted only as close as the Final Finishing Material thickness allows. This front comes with a screen and is a conforming safety barrier.



**Grace Front With a Traditions Front or Willowbrook Front Combination:**

A Traditions or Willowbrook Front can be mounted along with a Grace Front. First determine the desired depth perspective. Do you want the Grace Front Face close to the Traditions Face or Willowbrook Face? Do you want the Final Finishing Material behind the Grace Front or do you wish to use the Outside Guides which hold the Final Finishing Material outside the outer perimeter of the Grace Front? When installing a Grace Front with a Traditions or Willowbrook Front the screen of the Grace Front may be removed.



## SAFETY BARRIER

All decorative fronts that can be mounted on the ML39 Fireplace are certified Safety Barriers. If the Fireplace is installed without a decorative front then the Safety Barrier part number AA-11-02117 must be installed on the Fireplace. The Safety Barrier will mount on the glass frame of the fireplace. Follow the instruction manual with the Safety Barrier for installing the Safety Barrier. Never operate the fireplace without a certified Safety Barrier installed on the fireplace. Only use Mendota approved fronts with this fireplace.

## NON-COMBUSTIBLE FINISHING MATERIALS REQUIREMENTS

WARNING: The cross hatched areas labeled as "NONCOMBUSTIBLE ZONE" must be covered with noncombustible finishing materials that is 1-inch thick, minimum unless Adjustable Framing Brackets are utilized. (See section on Adjustable Framing Brackets for more information.) DO NOT ALLOW COMBUSTIBLE MATERIALS TO ENCROACH IN THIS AREA!

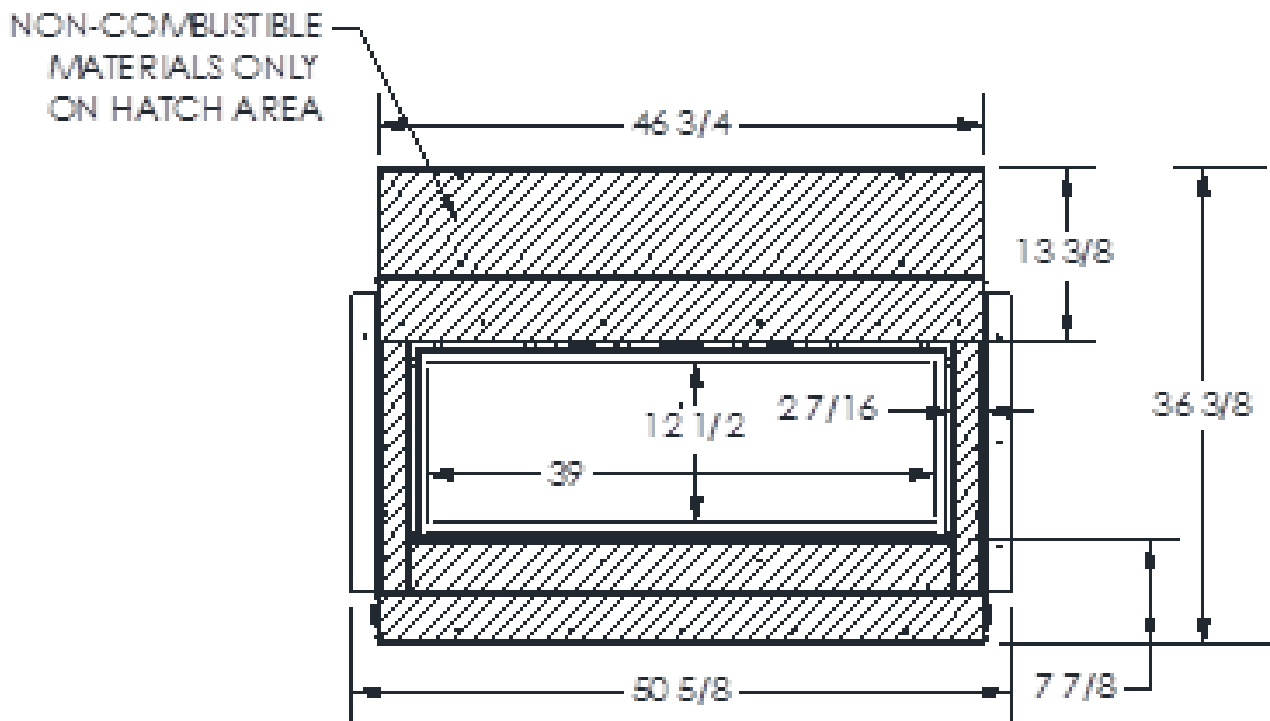

## **RAISED HEIGHT INSTALLATION OF ML39**

The ML39 Linear Gas Fireplace may be installed in an elevated configuration. Please consult the table, below to determine the maximum raised height allowable based on the internal ceiling height of the room this Fireplace is installed in.

Room Ceiling Height [DIM C]	MAXIMUM Floor to ML39 Bottom [DIM A]	MAXIMUM Floor to Bottom of Visible Glass [DIM B]	LIMITATIONS **MUST BE ADHERED TO**
84"	17"	26-3/16"	LIMITED by Clearance to Soffit. Use metal shield on soffit if you cannot conform.
96"	29"	38-3/16"	LIMITED by Clearance to Soffit. Use metal shield on soffit if you cannot conform.
108"	41"	50-3/16"	LIMITED by Clearance to Soffit. Use metal shield on soffit if you cannot conform.
120"	53"	62-3/16"	LIMITED by Clearance to Soffit. Use metal shield on soffit if you cannot conform.

If this fireplace is elevated high enough beyond the maximum on the table, above, you will be required to use a sheet metal shield which is mounted on the soffit directly above the vent cap spanning 36" wide centered over the vent cap and spanning the full depth of the soffit, spaced 1" down from the soffit surface using tubular spacers or stacked washers. This metal shield allows you to lower the clearance between Vent Cap Center and the metal shield to 12".

The ML39 Linear Fireplace may be installed directly on wood floor or any non-combustible solid flooring, except carpet and vinyl. The bottom edge of the visible glass will be located 9-3/16" up from the floor level in this configuration.

Mendota recommends that the ML39 be installed on an elevated wood framed support stand of at least 15" tall which will result in the bottom edge of the visible glass locating at 24" above the floor level of the room.

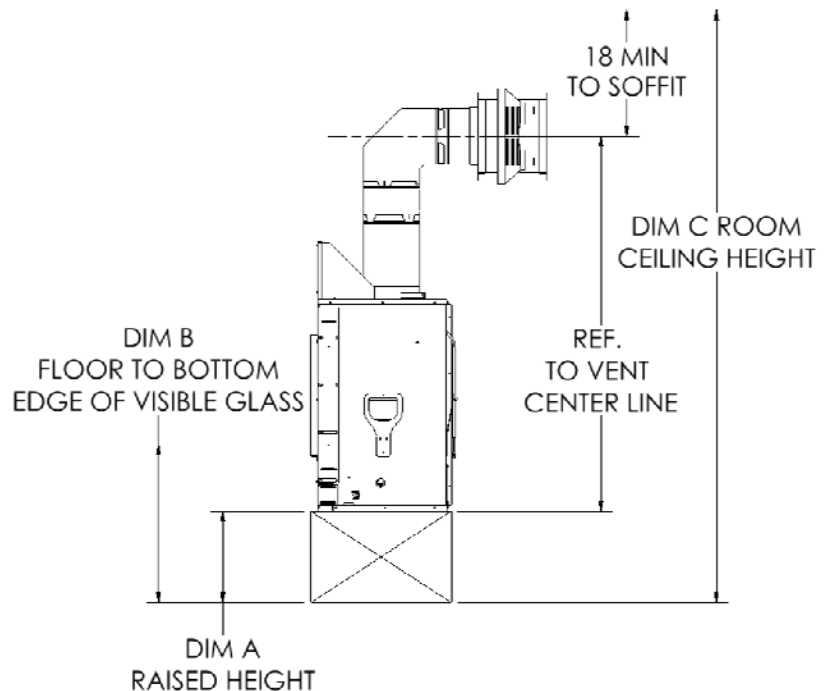

### **How To Determine The Proper Installed Height Of This Fireplace:**

Determine how individuals spend their time in the room this fireplace is to be installed. If time is spent mostly sitting on a chair or sofa, determine the eye level height of the shortest individual while this individual is sitting in the chair or sofa. Subtract 10" from the eye level height. This is the recommended height for the bottom edge of the visible glass.

This recommendation is strictly cosmetic and is not required to be adhered to.

## INSTALLATION OF FLAT PANEL TV ON TOP OF ML39

All flat panel TVs are solid state electronic appliances and are vulnerable to ambient temperatures greater than 90°F.

The ML39 is a gas fired heater and high ambient temperatures are to be expected in the immediate vicinity of this fireplace.

If the installation of a Flat Panel TV is desired above this appliance, proceed with caution. Follow the specific framing dimension and instructions provided below. Mendota does not warrant any TV installed above a Mendota Fireplace against heat damage.

Given, below, is the minimum TV Cavity framing and creation method. If possible, increase the distance between the top edge of the top convection air opening of this fireplace and the bottom edge of the TV cavity as much as possible beyond the 18" minimum requirement. Higher up means a cooler TV.

You **MUST** create a recessed 5" deep cavity to house the TV. **NEVER** mount any TV above this fireplace without creating a recessed cavity.

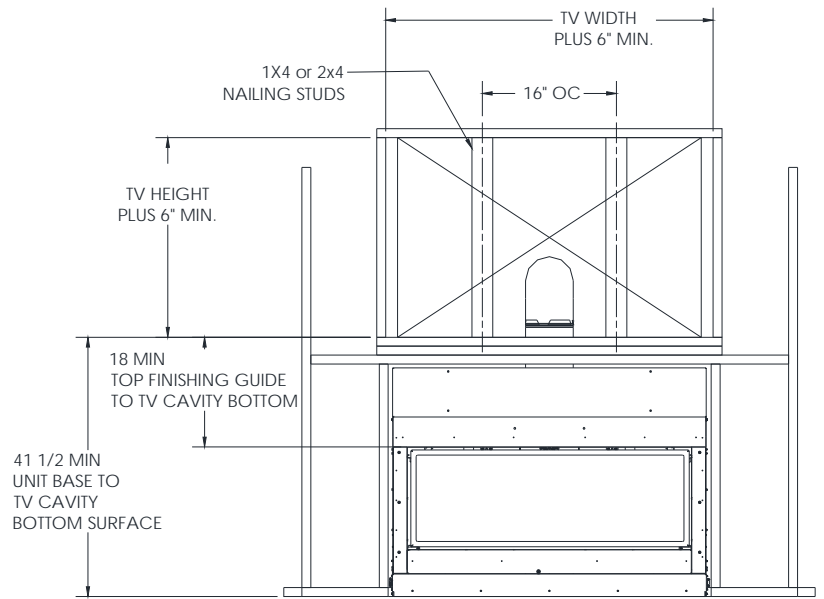

### Framing the TV Recessed Cavity

Use 2x6 lumber to create the basic frame for the TV cavity. Front edge of 2x6 lumber shall be flush with the front edge of the top rough framing 2x4 member. Locate the bottom 2x6 so its top surface is a minimum 18" above the top edge of the top convection air opening of this fireplace. Allow more distance if the ceiling height allows rather than using the 18" minimum.

The finished recessed cavity shall be 6" wider than the TV width, 6" taller than the TV height and 5" deep. Avoid using TV mounting brackets that are too deep. The TV's front-most surface must be recessed inward in the cavity at least 2 inches from the front surface of the final finish material.

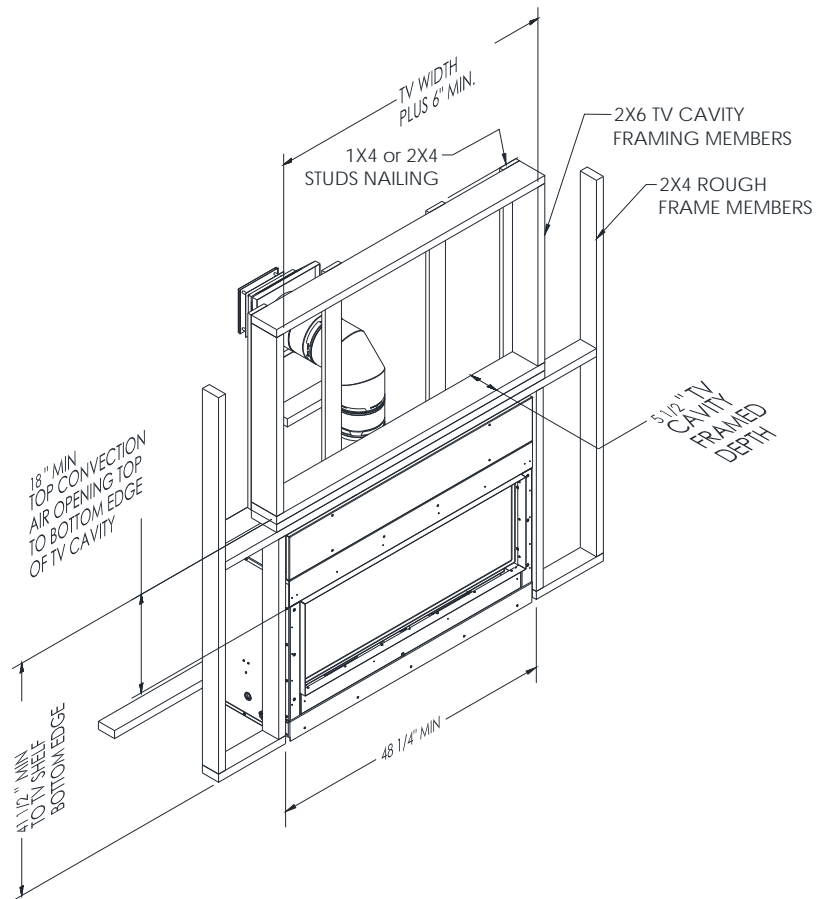

## **ENAMEL PANORAMIC LINER AND FLOOR PLATE INSTALLATION REQUIREMENT**

There exist 5 color options for the required Panoramic Panel Kit. The Panoramic Panel and a matching floor plate are available in Black, Midnight Black, Copper, Mocha Metallic and Silver Metallic attractive colors. You must select one colored Panoramic Panel Kit and install it before any test firing of this appliance.

The specific color kits and its corresponding part number are given, below:

<b>Kit Number</b>	<b>Color</b>
AA-11-02138	Black Reflective
AA-11-02139	Midnight Black
AA-11-02140	Copper
AA-11-02141	Mocha Metallic
AA-11-02142	Silver Metallic

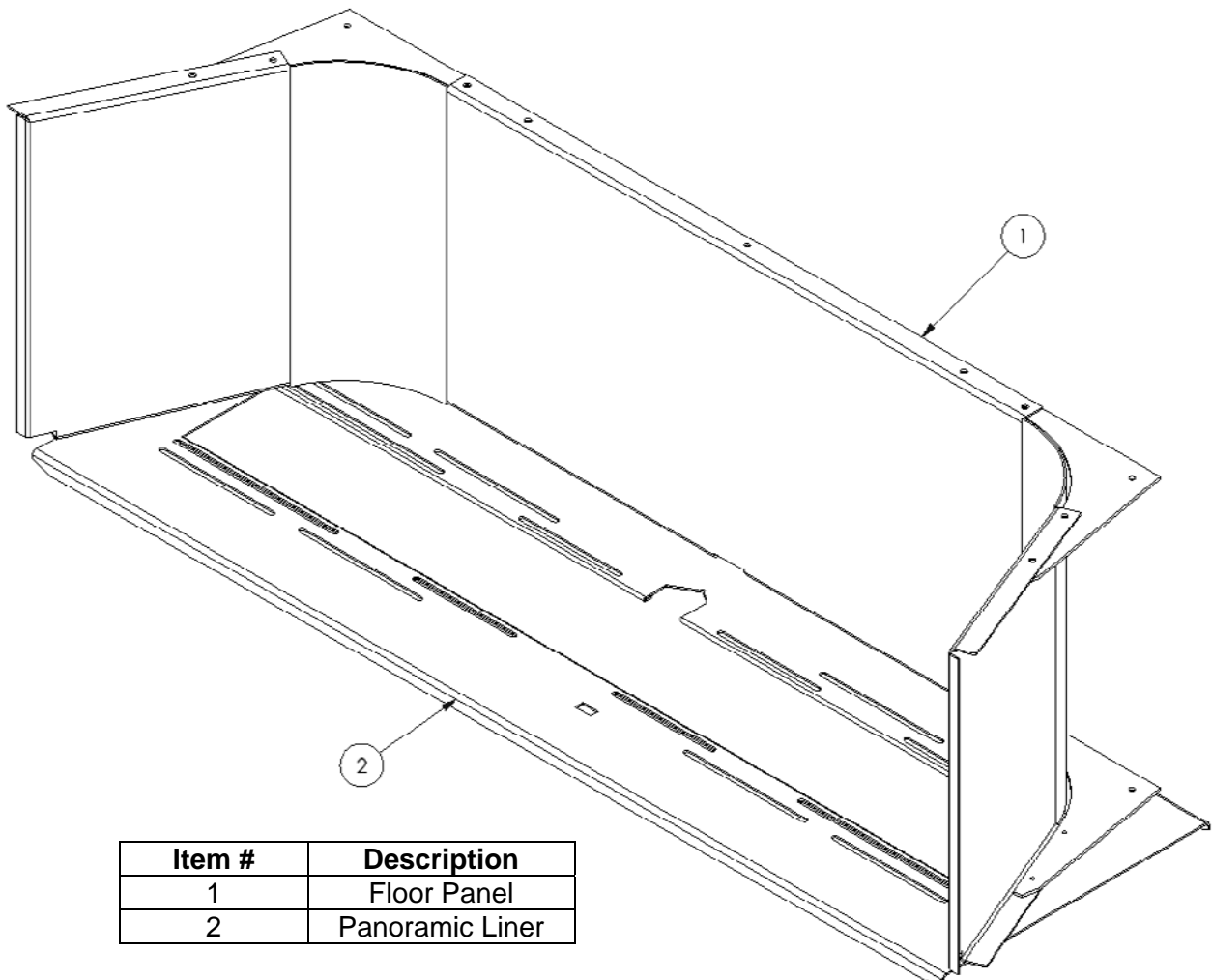

<b>Item #</b>	<b>Description</b>
1	Floor Panel
2	Panoramic Liner

## **BACKUP DC POWER INLET PORT INSTALLATION**

Under normal conditions when AC power is available, this appliance is designed to operate on 110 VAC power. During power outages, it is designed to operate using 6 V DC backup power. This appliance is supplied with a DC power inlet harness, a single gang outlet box and two single cover plates. In addition, a 4 X AA size battery pack and a connector harness is also supplied.

**Installation:** It is important that you install the supplied harness, outlet box and cover plate on the left side of this appliance. The DC Power Inlet harness is 6 feet long, allowing installation of the single gang box up to 4 feet to the left of this appliance. Install the single gang box at a maximum height of 18" to the center of the box or match the mounting height of this single gang box with the height of other AC outlets that are installed in the same room as this appliance. **WARNING: DO NOT STAPLE** the 6' DC Power Inlet Harness to the wall studs.

**Cover Plates:** Two cover plates are supplied and are White and Beige in color. If the home décor requires a different color other than the two supplied colors, obtain one from a local hardware store. Make certain that the cover you obtain is exactly the same dimensions as the ones supplied with this fireplace.

**Decal Installation:** A notification decal (label) is supplied with this fireplace that aids in identifying the DC Power Inlet. Attach this label to cover plate once installation is complete and verified.

**Instruct Homeowner:** Demonstrate to the homeowner how to attach the backup DC power pack during power outages. Instruct homeowner to retain the DC battery pack and the connecting harness in a safe and secure place for use during power outages.

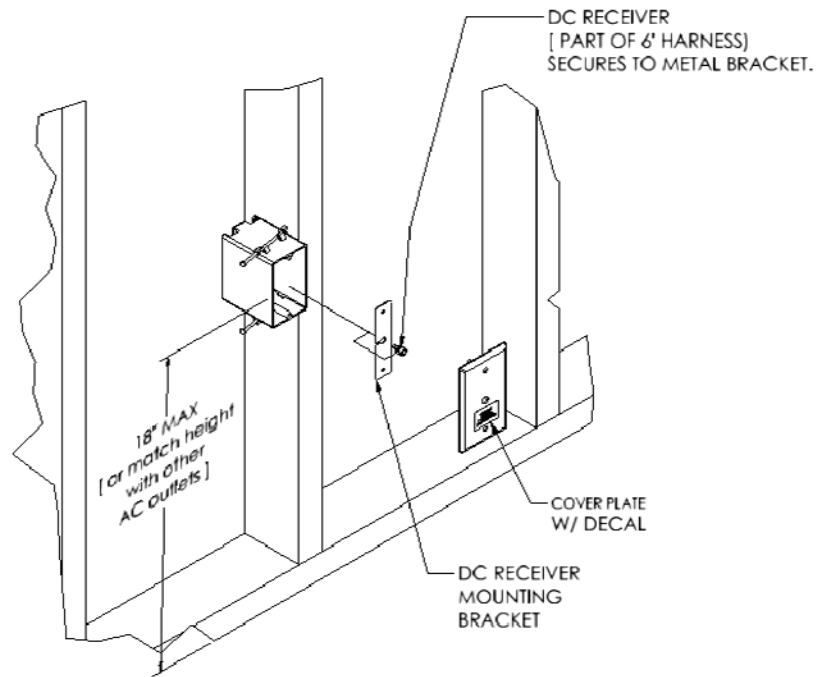

ATTACH DECAL  
TO COVER PLATE.

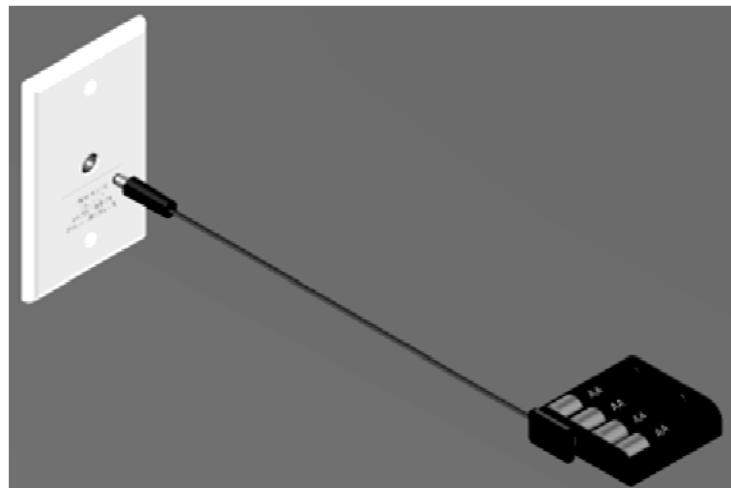



## **GENERAL INFORMATION**

Your Mendota Gas Fireplace has a state-of-the-art co-axial direct vent, sealed combustion system. This advanced combustion system brings in outside air for combustion and directly exhausts through an exhaust vent. The Mendota system maintains high air quality and assures proper operation in today's "air-tight" homes.

### **Accessing gas valve train and electrical junction box during initial installation**

To gain access, prior to placing this fireplace in a framed chase, to make the gas supply connection, to install LPG conversion kit, to check for gas leaks and to make initial electrical supply connection, remove the bottom two cover plates as shown, below. **Make certain the lowest cover plate is reinstalled before this fireplace is placed in the framed chase.**

### **Safety and Structural Concerns**

The ML39 Fireplace must be installed and serviced by a Mendota approved serviceperson. Any adjustments to burner, pilot and burner media must be made by a Mendota approved service person. If pilot goes out, always wait five (5) minutes before attempting to relight pilot.

### **Venting Requirements**

This Mendota Fireplace can be vented using any available brand DIRECT VENT coaxial pipe (5"X 8") off the top. Use only Mendota specified vents and vent caps when installing your fireplace. Closely follow venting locations, directions and re-

quirements. Observe the restrictions relating to vent position on exterior of home. Be sure all vent pipe sections are fully twist-locked and leak-proof. Be sure 1000° Silicate Stove Sealant is used on the inner pipe joints of all Simpson DuraVent pipe components and all adjustable pipe sections.

The Mendota Direct Vent Fireplace may be placed within 16 inches of adjacent sidewalls. The fireplace may be placed directly on concrete or wood flooring. If the appliance is to be installed on carpeting, vinyl or other combustible material other than wood flooring, the appliance shall be installed on a metal or wood panel placed on top of the flooring material and extending the full width and depth of the appliance. An 8" combustible mantel may be installed at a minimum of 12" above the heat outlet (35") up from the floor level of this fireplace) and no more than 8" out from wall at that height. Non-combustible (marble, brick, stone, etc.) mantels can be installed at any desired height above the top convection air opening. Combustible Mantels of any depth with a sheet metal protector plate in its under-side may only be installed **outside** the "NON-COMBUSTIBLE ZONE" above the top convection air opening.

Never block off convection air openings or paths. Always use Mendota decorative fronts and Mendota approved vent systems and vent caps.

**Hearth Protection Pad:** A non-combustible hearth protector is not required.

### **Aesthetic Considerations**

Burning or static fireplaces are a major aesthetic focus in any room. Locate your gas fireplace as you would a television set. The Mendota Hearth Gas Fireplace will be a continuing source of comfort and fascination. Corner installations will afford you the greatest potential for viewing in many rooms. This fireplace may be installed in an elevated position as long as 70 in. minimum distance is provided between the floor level of this fireplace and the room's ceiling surface.

### **Electrical Requirements**

Electronic Ignition System and an Accent Light system are included in this Mendota Direct Vent Fireplace. These devices require constant electrical power except during power outages. A 120-volt electrical service must be supplied at the fireplace location at the time of installation, on the left side of this fireplace. It must be electrically grounded in accordance with local codes, or in their absence, with the current edition of the National Electric Code ANSI/NFPA 70. Use of a wall switch control in the power supplied to this fireplace is NOT allowed.

Three loose wires are secured to a metal plate on the left side in the gas train cavity using a nylon wire tie. Cut the nylon wire tie and use wire nuts to connect house power to the three color-coded loose wires. A junction box is not required since the steel body of this appliance functions as a fire stop.

### **Manual Gas Shutoff Valve Installation Requirement**

Obtain a Manual Gas Shutoff Valve approved per local gas plumbing codes and install per local gas plumbing codes in the specified location. Manual Shutoff Valve is not supplied with this product.

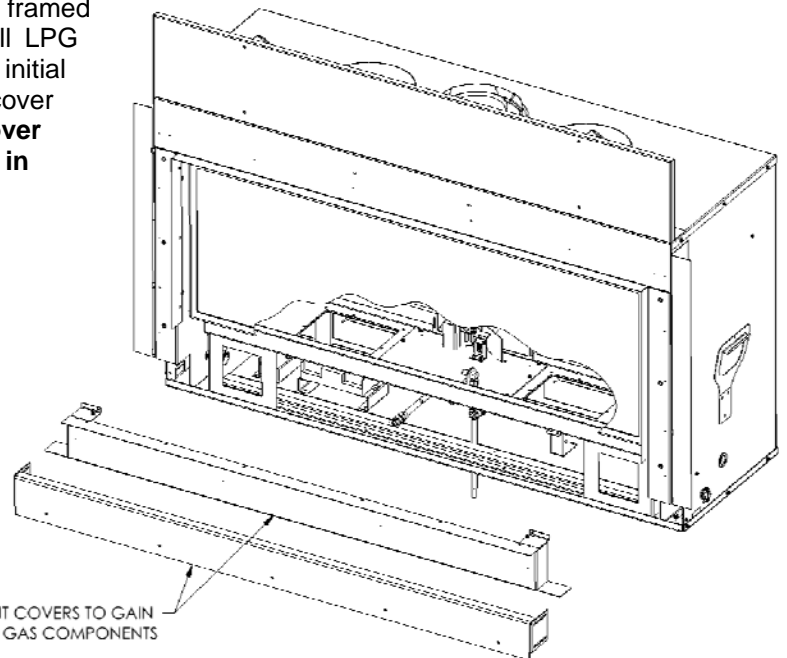

## GAS SUPPLY REQUIREMENTS

Correct gas pressure and proper gas supply line sizing is imperative to the successful performance of your Mendota gas fireplace. Be sure the gas supplier or plumber carefully checks for correct gas pressure and gas line sizing when installing the fireplace.

It is critical to check for gas leaks when connecting gas line to the fireplace -- check with soap & water solution.

Be sure to install "approved" flex gas line with brass-to-brass fittings to prevent gas leaks at connections.

Gas supply piping must include a drip leg to eliminate the possibility of contaminants entering the gas train.

Adhere strictly to local and national codes for entire installation.

Correct gas pressure and proper gas supply line sizing is required.

### Gas Supply Line Sizing

This Mendota Gas Fireplace comes equipped with a 1/2" N.P.T. Female inlet. Gas supply piping can enter the Fireplace cabinet on the left or right side. Location of gas supply entry hole on each side is the same and is shown in the image on the right.

An approved manual shut-off ball valve or keyed valve, as required by local codes must be installed at an accessible location. The appliance and its individual shut-off valve must be disconnected from the gas supply piping system during any pressure testing of that system at test pressures in excess of 1/2 PSIG (3.5 kPa).

The appliance must be isolated from the gas supply piping system by closing its manual shut-off ball valve during any pressure testing of the gas supply piping system at test pressures equal to or less than 1/2 PSIG (3.5 kPa).

A proper gas line diameter must be selected to run from the supply regulator to the Fireplace. Refer to the following table for proper gas pipe diameters. Strictly adhere to the correct pipe sizes.

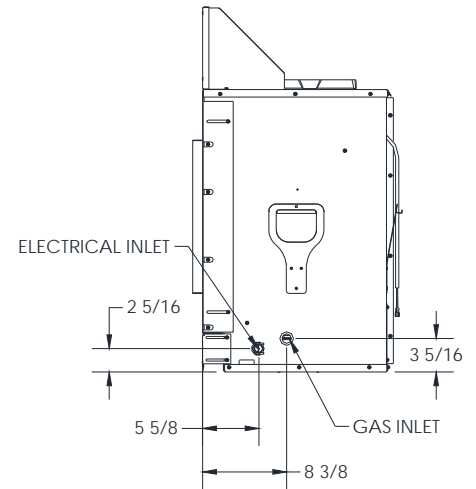

**WARNING:** Never use any type of pipe thread sealants or compounds on the seats of flare or compression connections.

PIPE LENGTH (FEET)	SCHEDULE 40 PIPE INSIDE DIA.		TUBING, TYPE L OUTSIDE DIA.	
	NAT.	L.P.	NAT.	L.P.
0-10	1/2" (1.3 cm)	3/8" (1.0 cm)	1/2" (1.3 cm)	3/8" (1.0 cm)
10-40	1/2" (1.3 cm)	1/2" (1.3 cm)	5/8" (1.6 cm)	1/2" (1.3 cm)
40-100	1/2" (1.3 cm)	1/2" (1.3 cm)	3/4" (2.0 cm)	1/2" (1.3 cm)
100-150	3/4" (2.0 cm)	1/2" (1.3 cm)	7/8" (2.3 cm)	5/8" (1.6 cm)
150-200	3/4" (2.0 cm)	1/2" (1.3 cm)	7/8" (2.3 cm)	3/4" (2.0 cm)

**NOTE:** Some areas allow coated stainless steel (CSST), copper tubing or galvanized pipe - check with local approval agencies and codes. **NEVER** use plastic pipe.

### Gas Pressure Checking Requirements

Inlet and manifold gas pressure checking taps are located on gas valve. Perform inlet and outlet pressure tests before completing the facing installation. Remove front access panel to gain access to the valve test ports. A qualified installer shall take pressure measurements at these ports to verify and set the correct inlet gas pressures during initial installation. Outlet gas pressures are factory-set and cannot be field adjusted.

**NOTE:** Check for gas leaks with soap and water solution on all factory joints and field installed joints during first firing of this appliance.

## GAS PRESSURE REQUIREMENTS

One of the main causes of operating problems with gas appliances can be improper gas pressure! Problems such as changes in flame color or configuration, gas pilot or burner outages, intermittent operation, changes in heat output, excessive burner noise, etc. are nearly always the result of changes in gas pressure or improper gas pressure at the time of the installation. The most important item to check during initial installation and the first thing to check when problems occur are the input and output gas pressures!

Gas is normally supplied to a residence at 1/2 PSI (13" - 15" W.C.) (3 KPA). A pressure regulator is then placed outside the residence, near the gas meter, which drops this pressure to 7" W.C. (1.8 KPA) (Nat. Gas). This "inches to inches" regulator is of adequate capacity to service the gas appliances (such as dryer, furnace, etc.). If this regulator's capacity is not sufficient to add the Gas Fireplace, an additional "inches to inches" regulator must be installed for the Fireplace. EXCEPTION: Some codes allow 2-PSI (1.4KPA) supplies to enter the residence, in which case "pounds to inches" regulators are used.

The following table provides information on correct gas pressure requirements. Be sure your gas supplier or plumber carefully follows this table.

**GAS PRESSURE REQUIREMENTS**

	DESIRED INLET PRESSURE	MINIMUM INLET PRESSURE	MAXIMUM INLET PRESSURE	MANIFOLD OUTLET PRESSURE	AIR SHUTTER POSITION*
NATURAL GAS	7.0" W.C. (1.75 kPa)	5.0" W.C. (1.12 kPa)	11" W.C. (2.61 kPa)	3.5" W.C. (0.87 kPa)	0 - 1/8 " OPEN (3 mm)
L.P. GAS	11.0" W.C. (2.75 kPa)	11" W.C. (2.75 kPa)	13.0" W.C. (3.24 kPa)	10.0" W.C. (2.5 kPa)	1/4" OPEN MIN. (5 mm)

**NOTE:** For altitudes above 2,000 feet some variations in air shutter settings may be required.

### Gas Valve Pressure Test Ports

Manifold pressure must be taken at the "OUTPUT PRESSURE" tap and inlet pressure at the "INLET PRESSURE" tap **with the burner operating** by a qualified installer. Perform pressure tests prior to installing fascia material around this fireplace.

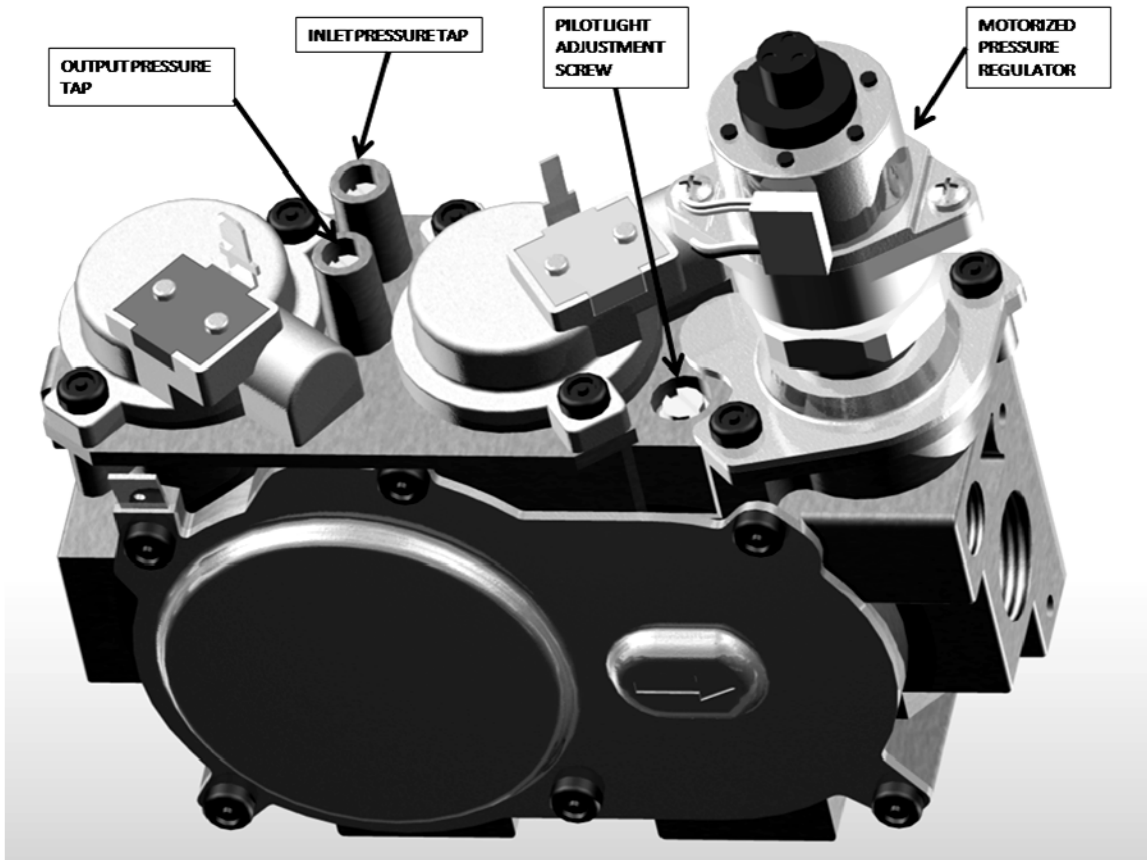

## **GAS INPUT RATE VERICATION REQUIREMENTS**

### **For Natural Gas**

1. Verify Main Orifice Size. The main orifice body has the orifice hole size stamped on it. NG orifice size shall be 33" for 0-2000 feet elevation and #34 for elevations exceeding 2000 feet.
2. Verify that the Manifold Gas Pressure is within 3.5" WC +/- 1/8":
3. Turn OFF all other appliances and their pilot flame in the home.
4. Read the main home gas supply meter reading.  
Write the initial reading here >> **Initial Gas Meter Reading** \_\_\_\_\_
5. Run this appliance for a period of 30 minutes on maximum flame size. Then turn off the main burner and pilot flame.
6. Read the main home gas supply meter reading after the 30 minutes of burn time.  
Write the reading here >> **Final Gas Meter Reading** \_\_\_\_\_
7. Subtract Initial Gas Meter from Final Gas Meter Reading. Write the result here >> \_\_\_\_\_
8. Multiply the result is step 7 by 100,000. Write the result here >> \_\_\_\_\_
9. Multiply the result in step 8 by 2. Write the result here >> \_\_\_\_\_

The result in step 9 shall be at least maximum Input Rate (34,250 Btu) for altitudes below 2000 Feet. For altitudes higher than 2000 feet, the result in step 9 shall be at least 32,500 Btu.

### **For LPG**

1. Verify Main Orifice Size. The main orifice body has the orifice hole size stamped on it. LPG orifice size shall be #50 for 0-2000 feet elevation and #51 for elevations exceeding 2000 feet.
2. Verify that the Manifold Gas Pressure is within 10" WC +/- 1/8".
3. Follow Steps 3 – 9 above.

The result in step 9 shall be at least maximum Input Rate (34,250 Btu) for altitudes below 2000 Feet. For altitudes higher than 2000 feet, the result in step 9 shall be at least 33,800 Btu.

## **GENERAL INSTALLATION INSTRUCTIONS**

**CAUTION:** Each installation must conform to all local, state and national codes. Refer to the national fuel gas code and local zoning and code authorities for details on installation requirements. The Mendota Fireplace must be vented to the outside in accordance with the latest edition of the National Fuel Gas Code. In the absence of local codes, the installation must conform to the most current edition of the National Fuel Gas Code ANSI Z223.1, also known as NFPA 54. **NOTE:** The Mendota ML39 Fireplace is approved for mobile home and bedroom installations. The ML39 Fireplace must be installed by a qualified service person.

**CAUTION:** The Mendota ML39 Fireplace may be installed in a manufactured (mobile) home after the first sale of the home. Manufactured home (mobile home) installation must conform with the Manufactured Home Construction and Safety Standard, Title 24 CFR, Part 3280, or, when such a standard is not applicable, the Standard for Manufactured Home Installations, ANSI A225.1/NFPA 501A, or CSA Z240.4-Gas Equipped Mobile Housing. Consult your local building official. **Note:** For mobile home installations unit must be bolted to the floor and properly grounded.

**High Altitude Installation Information:** Prior to installing at altitudes greater than 7500, please contact the Mendota technical service department for specific venting requirements and venting restrictions.

### **General Installation Information**

1. After selection of the desired fireplace location, prepare the rough opening using framing dimensions. Be sure to also prepare opening to allow for co-axial vent).

2. Check to make certain all venting requirements and locations are being followed.

3. This Fireplace is designed for installation into rough wood framing.

**NOTE:** FRAMING MATERIAL ABOVE FIREPLACE MUST MAINTAIN CORRECT CLEARANCE TO FIREPLACE AND VENT PIPES.

**WARNING:** One-inch clearance to sides & below and 3 inches clearance on top of horizontal vent sections and elbows are required.

4. **NOTE:** A removable panel in the enclosure for future visual inspection of flue connection is recommended.

5. Have an electrician install a 110-Volt supply to the junction box on lower left side of the fireplace cabinet. Connect wires using wire nuts. Make sure the grounding wires are properly connected and that the installation conforms to all local and national wiring codes.

6. Have gas supplier or qualified plumber install gas supply line to fireplace and connect to the ½" female connector. Be sure gas and plumbing instructions (see Page 25 and 27) and all local and national codes are carefully followed.

**IMPORTANT:** Any safety screen, guard, glass, grill etc. removed for servicing this fireplace must be replaced prior to operating this fireplace.

### **Blower Operation**

The Optional blower, if installed, can be regulated with the remote (included). **NOTE:** There will be a time delay in blower operation during "heat-up" (5 min.) and extended blower operation during "cool-down" of unit (12-1/2 min.).

### **Operation During Power Outages**

The fireplace is designed to operate during power outages on back-up batteries. The blower and Accent Light will not operate during the power outage.

## **GENERAL FLUE VENTING INSTRUCTIONS**

The Mendota Fireplace must be vented using the Mendota approved vent system components. Approved brands of vent components include DuraVent, Amerivent, Selkirk and Security vent pipes and venting components. All warranties will be voided and serious fire, health or other safety hazards may result from any of the following actions: Installation by unauthorized personnel; installation of any damaged component; unauthorized modification of vent system; installation of any components not approved by Mendota; failure to meet all clearance requirements; failure to properly twist-lock and positively seal all components. Consult local building codes before beginning the installation.

**WARNING:** Always maintain required clearances (air spaces) to combustibles to prevent a fire hazard. Do not fill air spaces with insulation. Check installation instructions for minimum clearance requirements between the outer walls of the vent pipe and nearby combustible surfaces. Be sure to check the vent termination clearance requirements from decks, windows, soffit, gas regulators, air supply inlets, and public walkways, as specified in these installation instructions and local building codes.

**Safety Precautions For The Installer:** 1) Wear gloves and safety glasses for protection; 2) Exercise extreme caution when using ladders or on rooftops; and 3) be aware of electrical wiring locations in walls and ceilings.

**WARNING:** This gas appliance and vent system must be vented directly to the outside of the building, and never attached to a chimney serving another solid fuel or gas burning appliance. Each direct vent gas appliance must have its own separate vent system. Common vent systems are prohibited.

To assure proper venting performance of this high-performance Mendota Direct Vent Fireplace, it is critical that all brands of vent pipe sections are sealed tightly and leak-proof. This means that all pipe sections must be carefully rotated into the fully "twist-locked" position.

**NOTE:** When using vent pipe and components that do not incorporate a fiberglass or graphite gasket at the inner exhaust tube joints, you must use Milpak 1000F silicate stove sealant (#65-06-00909). Aluminum foil tape may be used on the outer (air intake) pipe joint but is not mandatory. Local Codes may vary. Contact your dealer for proper materials.

**NOTE:** Do not separate telescoping sections. They must be used as complete assemblies. We strongly recommend that fixed length pipe sections be used in place of telescoping sections whenever possible.

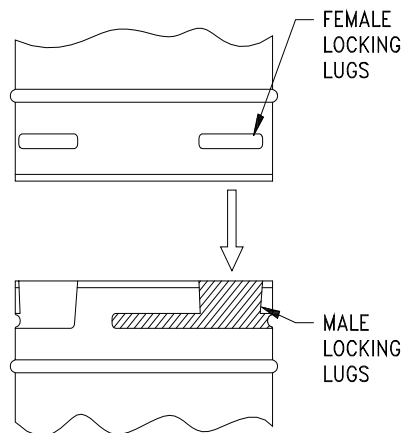

### **Component "Twist-Lock" Connection Procedure**

DuraVent and American Metals pipe and fittings are designed with special twist-lock connections. Twist-lock procedure is as follows: four (4) indentations, located on the female ends of pipes and fittings are designed to slide straight into the male ends of the adjacent pipes and fittings, by orienting the four pipe indentations so that they match and slide into the four entry slots on the male ends.

Push the pipe sections completely together then twist-lock one section clockwise, approximately  $\frac{1}{4}$  turn until the two sections are fully locked. The female locking lugs will not be visible from the outside on the black pipe or fittings. They may be located by examining inside of the female ends.

### **High Altitude Installation Information**

Prior to installing at altitudes higher than 7500, please contact the Mendota technical service department for specific venting requirements and venting restrictions.

# EXTERIOR VENT LOCATIONS AND RESTRICTIONS

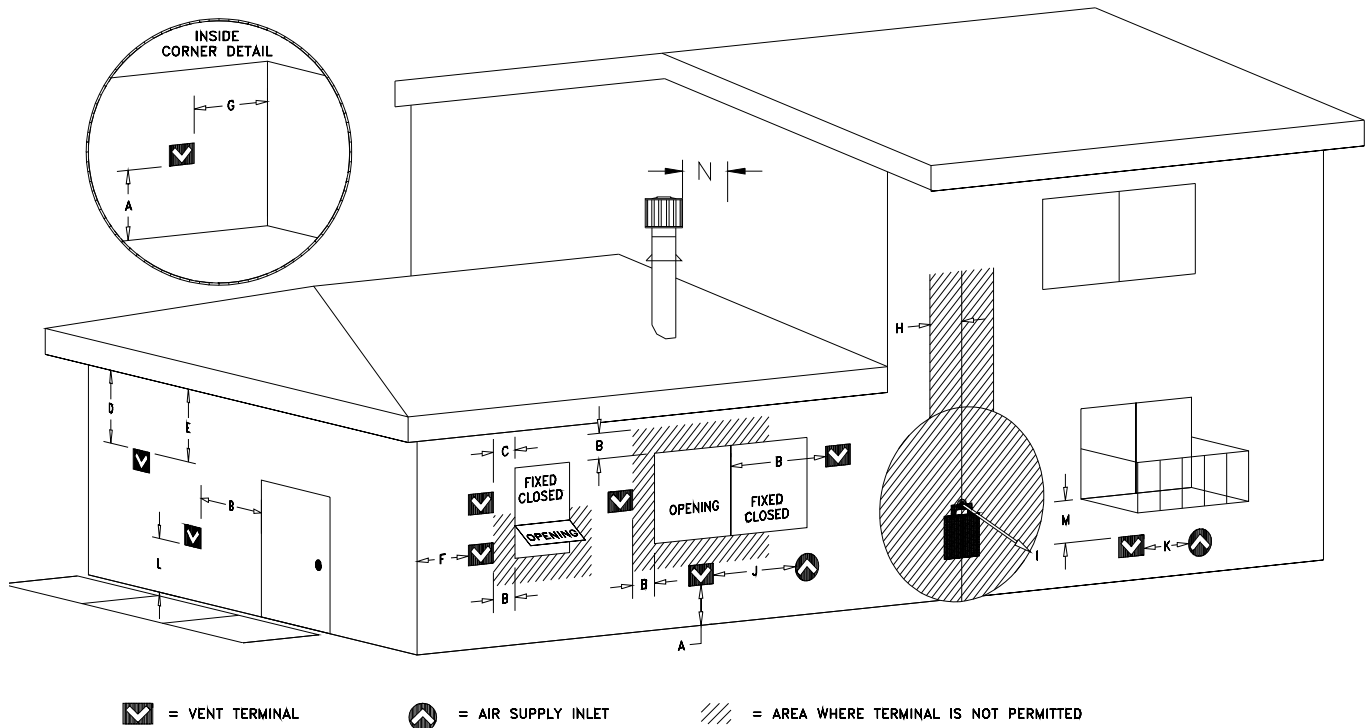

## ALL MEASUREMENTS FROM CENTER-LINE OF VENT CAP

✓ - Vent Terminal

⬆ - Air Supply Inlet

≡ - Area where terminal is not permitted

A = Clearance above grade, veranda, porch, deck, or balcony (\*12 inches (30 cm) minimum). Vinyl surfaces require 24" min.

B = Clearance to window or door that may be opened (\*12 inches (30 cm) minimum).

C = \*Clearance to permanently closed window (minimum 12 inches (30 cm) recommended to prevent condensation on window)

D = \*Vertical clearance to ventilated soffit located above the terminal from the center-line of the terminal 18" (47 cm) min.

E = \*Clearance to unventilated soffit 18" min (46 cm) min.

F = Clearance to outside corner - 7 inches (18 cm).

G = Clearance to inside corner - 12 inches (30 cm). Vinyl surfaces require 24" min (60 cm).

H = \*Not to be installed above a meter/regulator assembly within 3 feet (90 cm) horizontally from the center-line of the regulator

I = \*Clearance to service regulator vent outlet \*3 feet (92 cm) minimum.

J = \*Clearance to non-mechanical air supply inlet to building or the combustion air inlet to any other appliance. 12 inches (30 cm) minimum.

K = \*Clearance to a mechanical air supply inlet 6 feet (1.8 m) minimum

L = † Clearance above paved side-walk or a paved driveway located on public property (\*7 feet (2.1 m) minimum)

M = Clearance under veranda, porch, deck, or balcony (\*12 inches (30 cm) minimum ‡)

N = Minimum 24" horizontal clearance to any surface, such as an exterior surface, for vertical terminations.

† A vent shall not terminate directly above a sidewalk or paved driveway, which is located between two single-family dwellings and serves both dwellings.

‡ Only permitted if veranda, porch, deck, or balcony is fully open on a minimum of two sides beneath the floor.

\* As specified in CGA B1:19 Installation Codes (1991). **Note:** Local codes or regulations may require different clearances. Clearances are in accordance with local installation codes and the requirements of the gas supplier. Dégagement conforme aux codes d'installation locaux et aux exigences du fournisseur de gaz.

## FLUE VENTING COMPONENTS IDENTIFICATION

DO NOT SEPARATE TELESCOPING SECTIONS.  
USE TELESCOPING SECTIONS AS COMPLETE ASSEMBLIES.

**High Altitude Installation Information:** Prior to installing at altitudes higher than 7500, please contact the Mendota technical service department for specific venting requirements and venting restrictions.

ITEM	DESCRIPTION
1	6" or 7" PIPE (DuraVent 6"/Amerivent 7")
2	12" VENT STACK
3	24" VENT STACK
4	36" VENT STACK
5	48" VENT STACK
6	90° GALVANIZED ELBOW
	45° GALVANIZED ELBOW
7	ADJUSTABLE WALL THIMBLE (not shown)
8	ATTIC INSULATION SHIELD 12"
9	ROOF FLASHING (0/12 TO 6/12)
10	ROOF FLASHING (7/12 TO 12/12)
11	STORM COLLAR
12	VERTICAL VENT CAP
13	SUPPORT BAND
14	HORIZONTAL VENT CAP
15	FIRE STOP SPACER

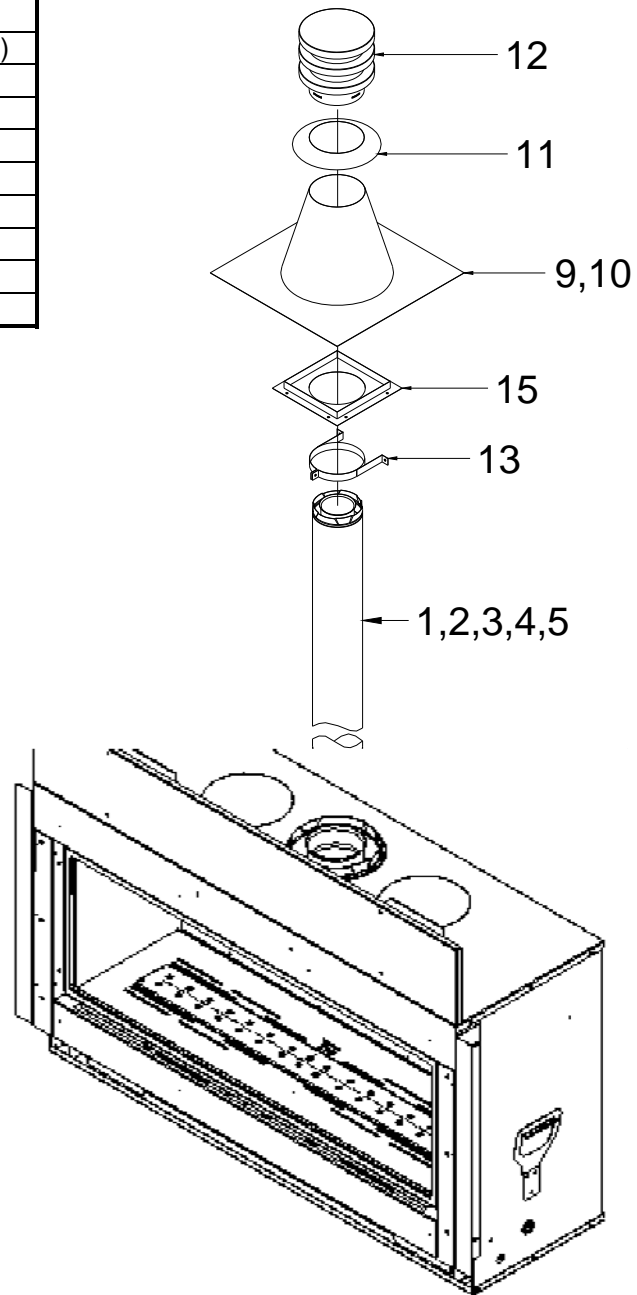
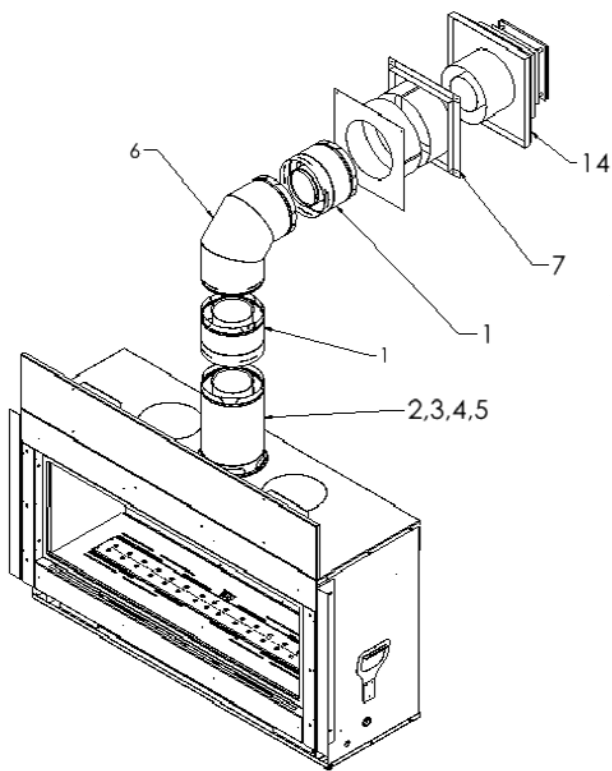



# MASTER FLUE VENTING REQUIREMENTS CHART

**NOTE:** THIS CHART IS APPLICABLE TO NATURAL GAS ONLY. FOR LPG INSTALLATIONS, SEE TABLE ON LEFT SIDE OF THE CHART, BELOW.

**Important Notes:**

- Always use the longest vertical starter pipe section as the first vertical section attached to the fireplace directly. 18" minimum vertical section is required for Natural Gas and 24" minimum vertical section for LPG applications.
- 6 inches maximum horizontal pipe run allowed with a 90° elbow connected to the 18" minimum vertical section Natural Gas and 24" vertical section LPG.
- Maximum Vertical Run allowed is 40 feet.
- Maximum Vent System length allowed is 42 feet.
- Maximum number of 90° elbows allowed in Zone A is 3 and in Zone B is 4.
- In **Zone "A"**, 32 feet maximum horizontal run allowed with a 4 feet starter section for NG and 27 feet maximum horizontal for LPG. If the starter vertical section is less than 4 feet, use the chart and reduce 4 feet for every 90° elbow installed after the first 90° elbow.
- In **Zone "B"**, 32 feet maximum horizontal run allowed NG (27 feet max for LPG) only if the first vertical section connected directly to the top of this fireplace is 4 feet or longer.

**High Altitude Installation Information:** Prior to installing at altitudes higher than 7500, please contact the Mendota technical service department for specific venting requirements and venting restrictions.

Natural Gas ONLY	
V min	H max
18 in.	6 in.
24 in.	6 ft.
30 in.	13 ft.
36 in.	19 ft.
42 in.	25-1/2 ft.
48 in.	32 ft.
4 ft. - 10 ft.	32 ft.
10 ft. - 40 ft.	Varies

**LPG	
V min	H max
24 in. (LPG)	6 in.
30 in.	8 ft.
36 in.	14 ft.
42 in.	20 ft.
48 in.	27 ft.
4 ft. - 10 ft.	27ft.
10 ft. - 40 ft.	Varies

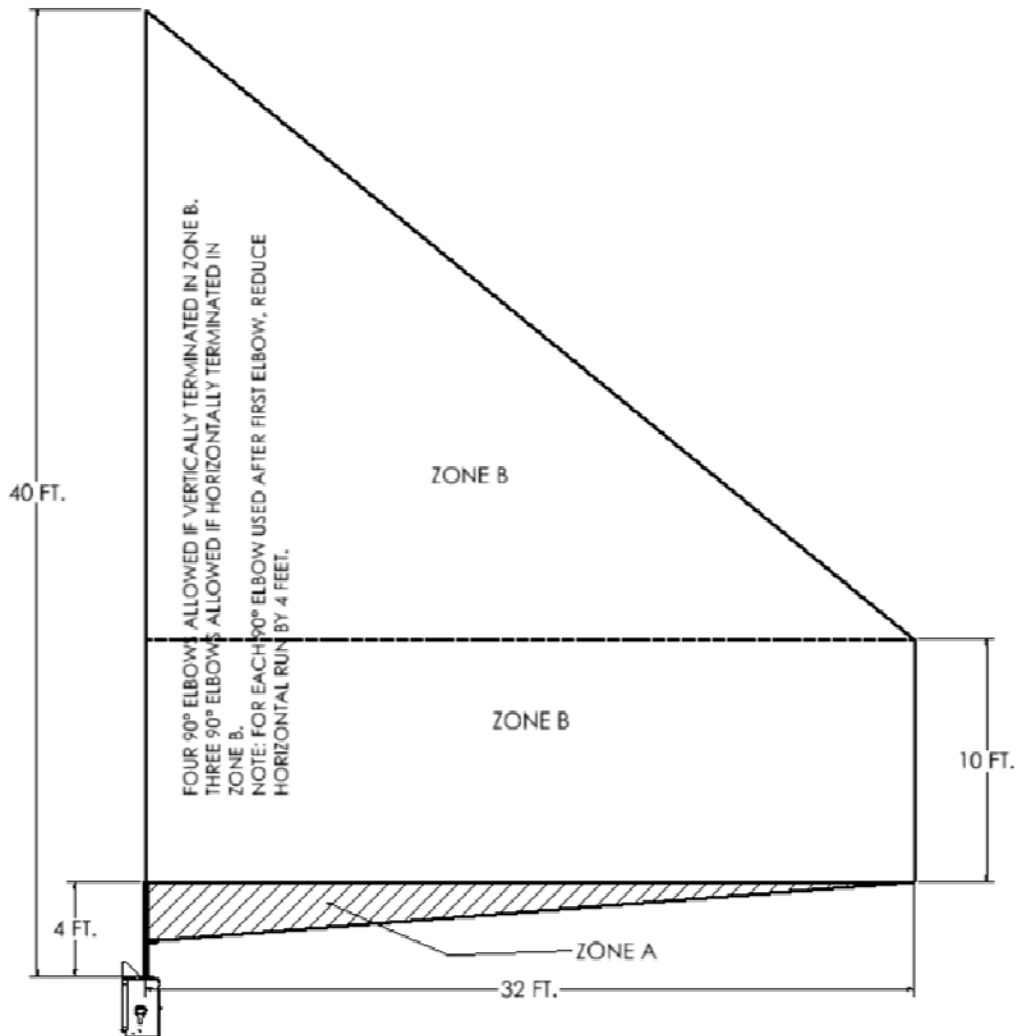

## **IMPORTANT VENTING CONFIGURATION NOTES**

**High Altitude Installation Information:** Prior to installing at altitudes higher than 7500, please contact the Mendota technical service department for specific venting requirements and venting restrictions.

### **Maximum Horizontal Run**

Maximum Horizontal Run allowed is 32 feet if a vertical starter section that is between 4 feet to 10 feet is connected directly to this fireplace's flue starter collar and no more than one (1) 90 degree elbow is used.

Maximum Horizontal Run allowed is 6" if an 18" vertical starter section is connected directly to this fireplace's flue starter collar.

### **Maximum Vent System Length**

Combined total length of all straight pipe sections in the vent system shall be less than 42 feet.

Combined total length of all straight pipe sections in the vent system shall be less than 42 feet when using three (3) 90-degree elbows or equivalent and terminating the vent system horizontally in Zone "B".

Combined total length of all straight pipe sections in the vent system shall be less than 42 feet when using four (4) 90-degree elbows or equivalent and terminating vertically.

### **How To Calculate The Vent System Lengths**

For calculation purposes and usage of charts in this manual, simply add the lengths of all individual straight pipe sections.

For example: if you use two 2-foot lengths and one 4-foot length, the total vent system length will be  $2+2+4 = 8$  feet.

### **Using 90° Elbows in Zone "B"**

The ML39 Fireplace by MENDOTA allows maximum flexibility in the use of 90° elbows in the vent system. The length of the first straight vertical section directly connected to the fireplace's starter collar determines the maximum horizontal run and the number of 90° elbows allowed for this fireplace.

For vent systems that provide a starting vertical section that is 4 feet or longer, you may connect up to 32 feet of horizontal pipe. For each 90° elbow installed after the first 90° elbow on top of the first 4 ft. section connected to the starter collar of this fireplace, reduce maximum allowed horizontal run by 4 feet.

### **Using 90° Elbows in Zone "A"**

For vent systems that provide a starting vertical section less than 4 feet, the following rules apply:

a. You must use the Master Flue Venting Requirements Chart. See Zone "A" below the 4' vertical run line.

b. A single 90° vertical-to-horizontal elbow is already calculated into the allowable maximum 32' horizontal run. The Venting Requirements Chart assumes that for all horizontal runs calculated, one 90° elbow is used within the venting system.

**Each additional 90° elbow reduces the maximum horizontal distance by 4'.**

c. If you plan to use more than one 90° elbow within the vent system, first use the Master Flue Venting Requirements Chart and calculate the maximum horizontal run you are allowed based on the first vertical section connected directly to the fireplace. From this maximum horizontal run calculated, subtract 4 feet for each additional 90° elbow you will use.

**Example 1:** Assume you are using a 3 feet long starter vertical section. This should allow, per Master Flue Venting Requirements Chart, 19 feet of horizontal run. If you want to use three 90° elbows, subtract 8 feet for two elbows from the 19 feet maximum allowed [4 feet for each elbow after the first elbow]. This yields 11 feet as the maximum horizontal run that you are allowed to install using the 3 foot vertical starter section.

**CAUTION:** If a vertical-to-horizontal discharge elbow or a horizontal-to-horizontal discharge elbow is enclosed within a wall, floor or ceiling, a top air space clearance of 3" must be maintained above the elbow body.

### **Using 45-Degree Elbows**

Two 45-degree elbows may be used in place of one 90-degree elbow. On 45-degree runs, one foot of diagonal pipe is equal to 8-1/2 inches horizontal run and 8-1/2 inches vertical run. Two 45-degree elbows may be connected directly to the vent starter adapter on this fireplace to create an offset to provide the required clearances to combustible framing or sheathing materials.

Two 45-degree elbows may be connected directly to the top of this fireplace to create a horizontal offset. 20 feet maximum horizontal run allowed with this offset configuration only if the first vertical section connected directly to the last 45-degree elbow is more than 4 feet long. For maximum allowable horizontal distances with the 45-degree offsets, see the Master Venting Configuration Chart.

**NOTE:** Each horizontally positioned 45° elbow reduces the maximum horizontal distance by 1½'.

**Support:** Horizontal runs of pipe will require one vent support for every 3 ft. of pipe.

# APPROVED VENT SYSTEMS QUICK REFERENCE CHART

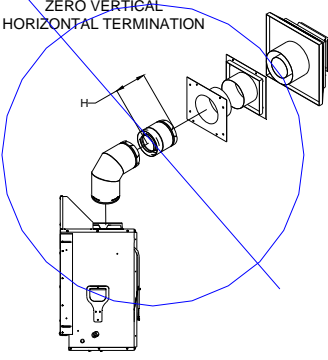
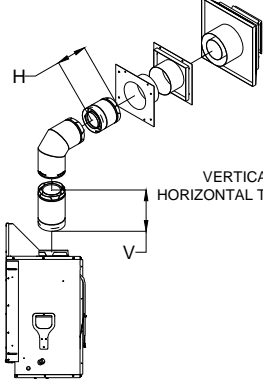
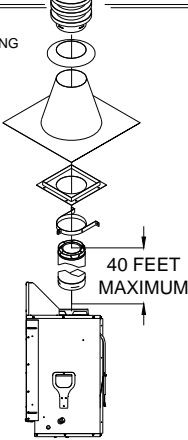
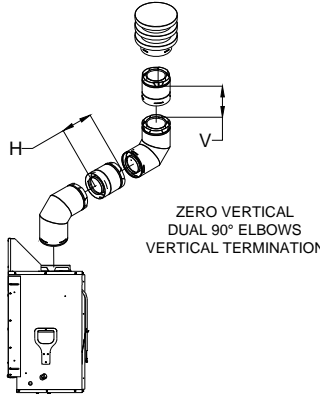
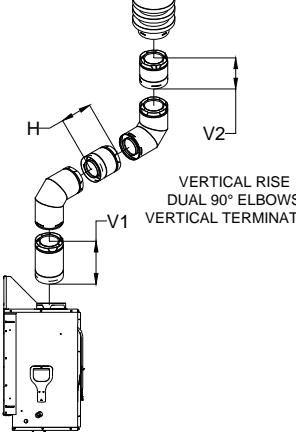
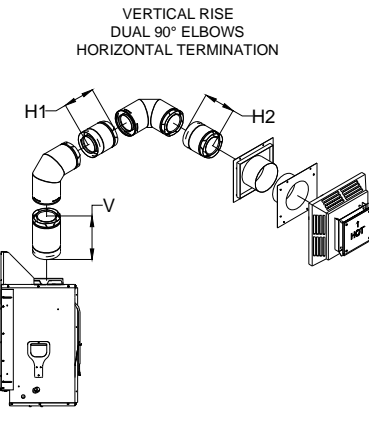
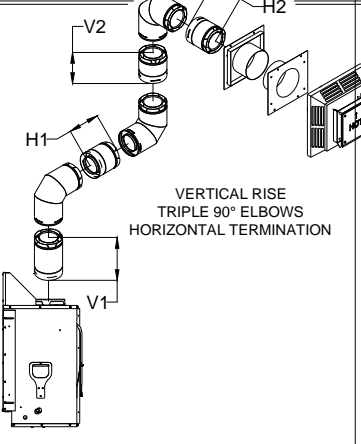
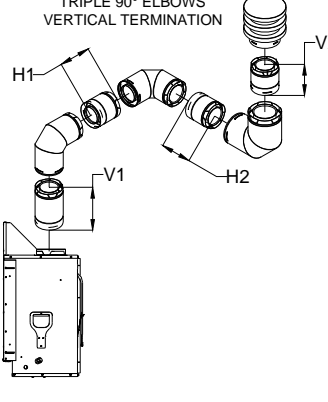
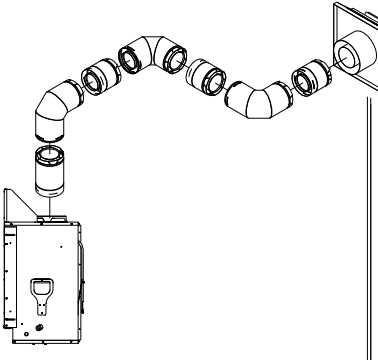
 <p>ZERO VERTICAL HORIZONTAL TERMINATION</p>	 <p>HORIZONTAL RISE VERTICAL RISE HORIZONTAL TERMINATION</p>	 <p>STRAIGHT UP, VERTICAL VENTING</p> <p>40 FEET MAXIMUM</p>
<p><b>NOT ALLOWED</b></p>	<p><b>APPROVED</b></p>	<p><b>APPROVED</b></p>
 <p>ZERO VERTICAL DUAL 90° ELBOWS VERTICAL TERMINATION</p>	 <p>HORIZONTAL RISE VERTICAL RISE DUAL 90° ELBOWS VERTICAL TERMINATION</p>	 <p>VERTICAL RISE DUAL 90° ELBOWS HORIZONTAL TERMINATION</p>
<p><b>APPROVED</b></p>	<p><b>APPROVED</b></p>	<p><b>APPROVED</b></p>
 <p>VERTICAL RISE TRIPLE 90° ELBOWS HORIZONTAL TERMINATION</p>	 <p>VERTICAL RISE TRIPLE 90° ELBOWS VERTICAL TERMINATION</p>	 <p>THREE HORIZONTAL DISCHARGE 90° ELBOWS <b>APPROVED w/ RESTRICTIONS</b></p>
<p><b>APPROVED</b></p>	<p><b>APPROVED</b></p>	<p><b>APPROVED</b></p>

## **MINIMUM RISE HORIZONTAL TERMINATION**

The ML39 Fireplace must be installed by a qualified Mendota approved serviceperson. When the minimum 18" (24" for LPG) vertical and following 90-degree elbow is connected directly to this fireplace, the horizontal centerline of the 90° elbow will be 51 7/16" (57 7/16 for LPG) inches up from the floor level of this Fireplace.

Use "fixed" pipe sections in place of adjustable pipe sections wherever possible. 1000° sealant must be used on ALL inner pipe joints that do not have factory installed gasket material.

Always maintain 1" clearance from vent pipe sides and bottom to combustibles, 3" clearance on top of pipe on horizontal runs and on top of horizontal discharge elbows. Do not fill air spaces with insulation or other material.

Position the fireplace in desired location. See Exterior Vent Locations and Restrictions page for guidelines on proper vent cap placement on the exterior of home. Check to determine if wall studs are in the way when venting system is attached. If this is the case, you may want to adjust the fireplace location or modify the exterior wall framing to allow the vent system to penetrate the wall.

Measure from the floor level of the fireplace up 51 7/16" inches [add 1/4" rise for every foot of horizontal run] and mark wall directly at the center of where the vent pipe will penetrate the exterior wall.

Cut and frame a 10-3/4" wide x 10-3/4" high opening in the wall. The hole must be positioned so the vent system will run level or have a 1/4" rise per foot of run AND be perpendicular to the wall. The height of the opening must be located to meet all local and national building codes. Do not allow the termination to be easily blocked or obstructed. If wall being penetrated is non-combustible material, i.e. masonry block, brick, etc., a 9-inch diameter hole is acceptable.

Attach the 18" vertical section to the fireplace starter adapter. Attach a 90-degree elbow then a 6" horizontal section. Be sure all vent component connections are in their fully twist-locked position and are leak-proof. Be sure 1000° sealant is used on the inner pipe joints of all pipe sections manufactured by Simpson DuraVent. The length of the horizontal piece that fits through the wall will be determined by the location of the fireplace relative to the wall. For a normal installation where this fireplace is installed directly against an exterior wall constructed using 2x4 lumber or 2x6 lumber, only a 6" horizontal section is required. There MUST be a minimum of 1" air space clearance to combustibles from all vent components (3" above horizontal runs and horizontal discharge elbows).

A wall thimble must always be used when penetrating combustible wall materials.

From the exterior of the home, slide the horizontal vent cap over the end of the horizontal pipe and tightly secure the cap to the wall with screws. Seal with a high quality caulking.

**NOTE:** Combustible wall thickness must be 4" to 8" maximum

**NOTE:** Vent Cap body shall not be recessed into wall or siding.

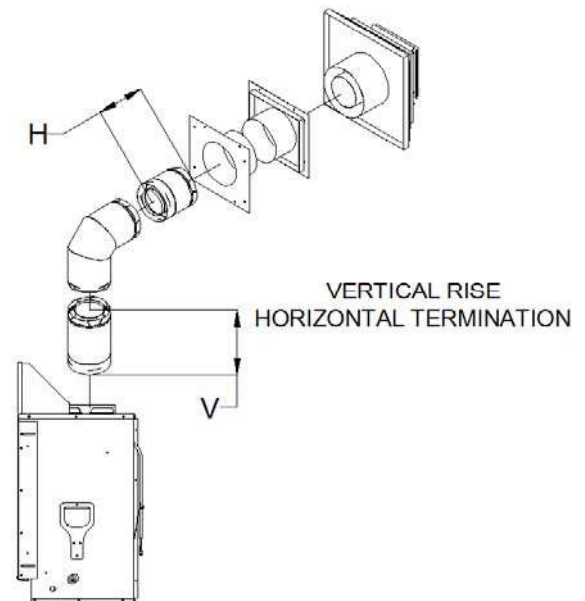
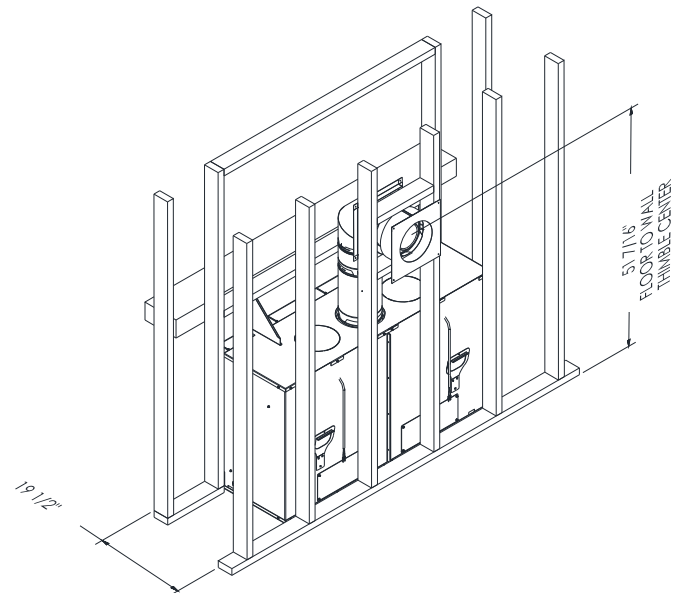

## VERTICAL RISE HORIZONTAL TERMINATION

The minimum vertical section required to be connected directly to the starter adapter on this fireplace is 48 inches when used with a maximum horizontal run of 32 ft. If the total length of the vertical sections connected directly to the starter adapter on this fireplace is between 4 feet and 41 feet, you are allowed a maximum 32 feet horizontal run. For other venting configurations within these maximum limits, see Master Flue Venting Requirements Chart, Zone A and Zone B.

Combined total length of all pipe sections (include restriction of elbows) in the vent system shall be less than 42 feet.

**NOTE:** The horizontal run of vent pipe must be level or have a ¼" rise for every 1' of run toward the termination. Never allow the vent to run downward. This will cause high temperatures and the possibility of a fire.

This ML39 Fireplace must be installed by a qualified Mendota service person

Position the fireplace in desired location. See Exterior Vent Locations and Restrictions page for guidelines on proper vent cap placement on exterior of home. Check to determine if wall studs are in the way when vent system is attached. If this is the case you may want to adjust the fireplace location.

Locate where vent pipe will pass through any ceilings and will penetrate the outside wall. Since vent pipe sections "overlap" we suggest pre-assembling and measuring the total vent pipe run so you can more accurately locate the point where the vent pipe will penetrate the outside wall. Be sure all vent components are properly twist locked and leak-proof. Be sure 1000° sealant is used in the inner pipe joints of all pipe sections manufactured by Simpson DuraVent.

Cut and frame a 10-3/4" wide x 10-3/4" high opening in the outside wall openings and 10" x 10" opening in ceiling openings. The outside wall hole must be positioned so the vent system will run level or have a ¼" on rise AND be perpendicular to the wall. The height of the opening must be located to meet all building codes and not allow the termination to be easily blocked or obstructed. A ceiling fire stop spacer is required at any floor (ceiling) opening.

Connect vent pipe to the fireplace adapter on top of fireplace vent outlet.

The horizontal pipe must end flush with the exterior wall of the home. Horizontal pipe will require a proper support every 3 ft. of vent pipe. THERE MUST BE A MINIMUM OF 1" CLEARANCE TO COMBUSTIBLES FROM ALL VENT PIECES ON THE SIDES AND BOTTOM AND 3" ABOVE HORIZONTAL RUNS).

A wall thimble must always be used when penetrating combustible wall materials.

**NOTE:** Combustible wall thickness must be 4" to 8" maximum. From the exterior of the home, slide the horizontal vent cap over the end of the horizontal pipe and tightly secure the vent cap to the wall with screws. Seal with high quality caulking.

**NOTE:** Venting terminal (Vent Cap) should not be recessed into wall or siding.

**NOTE:** DO NOT SEPARATE TELESCOPING SECTIONS. THEY MUST BE USED AS COMPLETE ASSEMBLIES.

V min	H max
18 in.	6 in.
24 in.	6 ft.
30 in.	13 ft.
36 in.	19 ft.
42 in.	25-1/2 ft.
48 in.	32 ft.
4 ft. - 10 ft.	32 ft.
10 ft. - 40 ft.	Varies

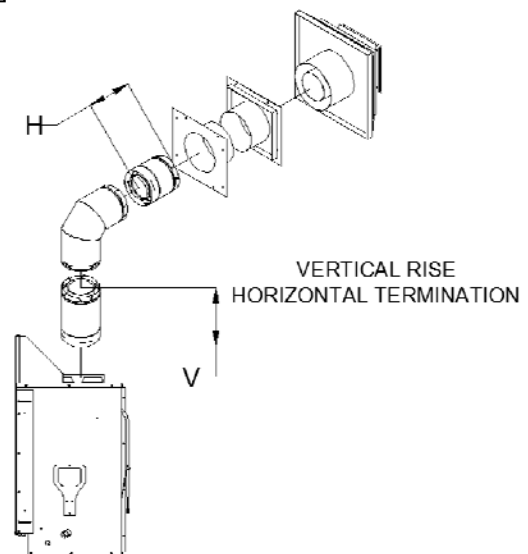

VERTICAL RISE  
DUAL 90° ELBOWS  
HORIZONTAL TERMINATION

V min	H1 +H2 max
24 in.	2 ft.
30 in.	9 ft.
36 in.	15 ft.
42 in.	21-1/2 ft.
48 in.	28 ft.
4 ft. - 10 ft.	28 ft.
10 ft. - 40 ft.	Varies

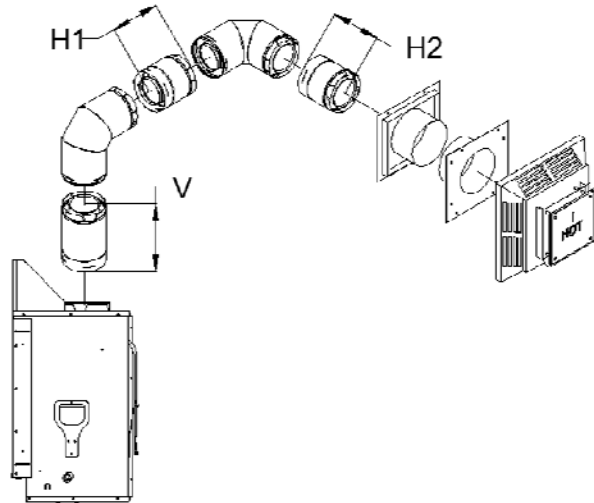

V1 min	H1 max	V2 max	H2 max
18 in.	6 in.	36-1/2 ft.	42 ft – H1-V2
24 in.	6 ft.	32 ft.	42 ft – H1-V2
30 in.	13 ft.	27-1/2 ft.	42 ft – H1-V2
36 in.	19 ft.	20 ft.	42 ft – H1-V2
42 in.	25-1/2 ft.	6-1/2 ft.	42 ft – H1-V2
48 in.	32 ft.	10 ft.	42 ft – H1-V2
4 ft. - 10 ft.	32 ft.		Varies
10 ft. - 40 ft.	Varies		Varies

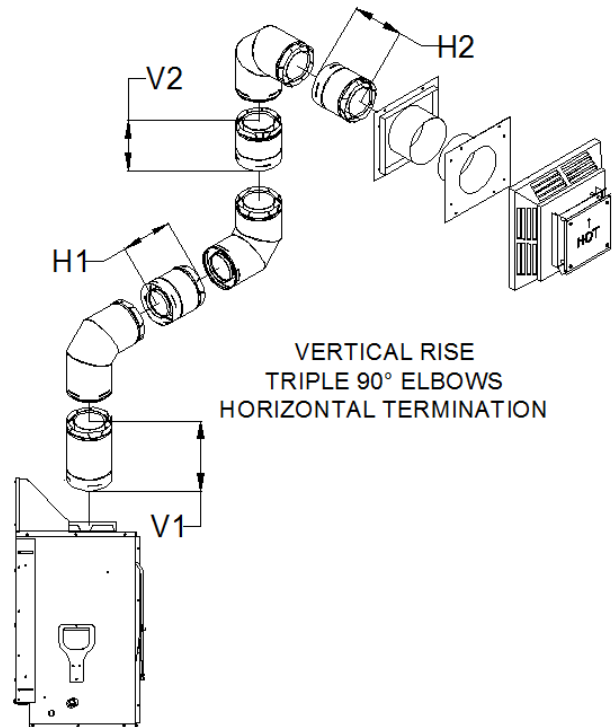

VERTICAL RISE  
TRIPLE 90° ELBOWS  
HORIZONTAL TERMINATION

## **VERTICAL THROUGH-THE ROOF VENTING**

The maximum vertical run of vent pipe is 40 ft. from the top of the fireplace. The fireplace will support a run of a maximum of 40 ft. Maintain 1" air space clearances on all sides of vents (3" above horizontal runs).

If an offset is required directly on top of the fireplace, two 45° elbows may be connected directly to the top of this fireplace to create a horizontal offset then to run upwards vertically. Doing so will continue to allow the use of the 40 feet maximum vertical run.

The ML39 Fireplace must be installed by a qualified Mendota approved serviceperson.

1. Place the fireplace in its desired location. Drop a plum bob from the ceiling to the position of the fireplace flue exit. Mark the location where the vent will penetrate the ceiling. Drill a small hole at this point. Next, drop a plum bob from the roof to the hole previously drilled in the ceiling. Mark and drill the spot where the vent will penetrate the roof. Determine if ceiling joists, roof rafters or other framing will obstruct the venting system. You may wish to relocate the fireplace or to offset, to avoid cutting load bearing members.
2. Cut and frame a 10" x 10" opening in the ceiling centered on the hole drilled in Step No. 1.
3. To determine the length of the vent pipe required, measure the distance from the fireplace flue outlet to the ceiling, the ceiling thickness and the vertical rise in the attic or second story and allow sufficient vent height above roofline. For two story installations, fire stops are required at each floor level. If an offset is needed in the attic, additional pipe and elbows will be required.
4. Assemble the desired lengths of vent pipe and elbows to reach from the fireplace flue outlet. Ensure that all vent pipe and elbow connections are in their fully twist-lock position and that inner pipe joints (DuraVent only) are sealed and are leak-proof. Maintain 1" airspace clearances to combustibles (2" above horizontal runs). Cut a 10" x 10" opening in the roof, centered in the small drilled hole placed in the roof in No. 1. The opening should be a sufficient size to meet all clearance requirements. Continue to assemble lengths of pipe and elbows necessary to reach up through the roofline. Galvanized pipe and elbows may be utilized in the attic, as well as above the roofline. The galvanized finish is desirable above the roofline due to its higher corrosive resistance.
5. If an offset is necessary, it is important to support the vent pipe every 3 ft. to avoid excessive stress on the elbows and possible separation. Wall straps are available for this purpose.
6. Slip the flashing over the pipe sections protruding through the roof. Secure the base of the flashing to the roof with roofing nails and seal flashing to roof. Ensure the roofing material overlaps the top edge of the flashing. Verify you have at least the minimum clearance to combustibles at the roofline.
7. Continue to add pipe sections until the pipe and the vent cap meet the minimum building code requirements, as outlined in No. 8 on the following page.
8. For multi-story vertical installation, a ceiling fire stop is required at the second floor and any subsequent floors. The opening should be framed to 10" x 10" inside dimensions as described in step No. 5.
9. Any occupied areas above the first floor, including closets and storage spaces, which the vertical vent passes through, must be enclosed. The enclosure may be framed and sheet rocked with standard construction materials, however, be sure to maintain minimum allowable clearances between the outside of the vent pipe and the combustible surfaces of the enclosure.
10. Height "H" from roof surface to the top of vent cap can be determined as follows:

Complete installation with storm collar and vent cap.

ROOF PITCH	"H" DIMENSION	
	FEET	METERS
FLAT to 6/12	1	.3
7/12 to 9/12	2	.6
10/12 to 12/12	4	1.2
13/12 to 16/12	6	1.8
17/12 to 21/12	8	2.4

STRAIGHT UP,  
VERTICAL VENTING

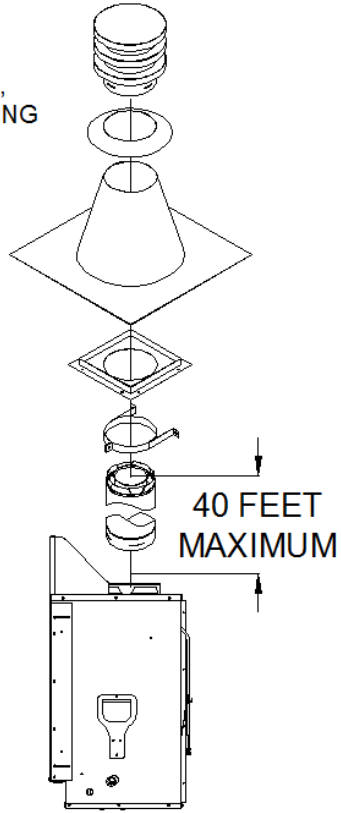

V1 min	H max	V2 max
18 in.	6 in.	38-1/2 ft.
24 in.	6 ft.	34 ft.
30 in.	13 ft.	27 ft.
36 in.	19 ft.	21 ft.
42 in.	25-1/2 ft.	14-1/2 ft.
48 in.	32 ft.	10 ft.
4 ft. - 10 ft.	32 ft.	Varies
10 ft. - 40 ft.	Varies	Varies

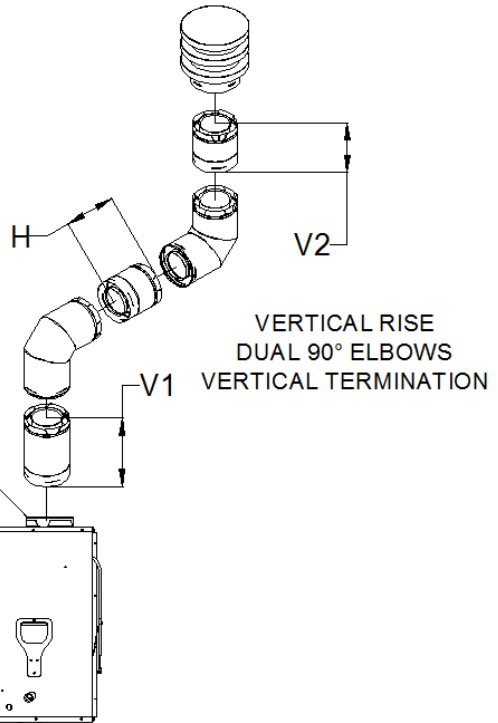



V1 min	H1 +H2 max	V2 MAX
24 in.	2 ft.	10 ft.
30 in.	9 ft.	10 ft.
36 in.	15 ft.	10 ft.
42 in.	21-1/2 ft.	10 ft.
48 in.	28 ft.	10 ft.
4 ft. - 10 ft.	28 ft.	Varies
10 ft. - 40 ft.	Varies	Varies

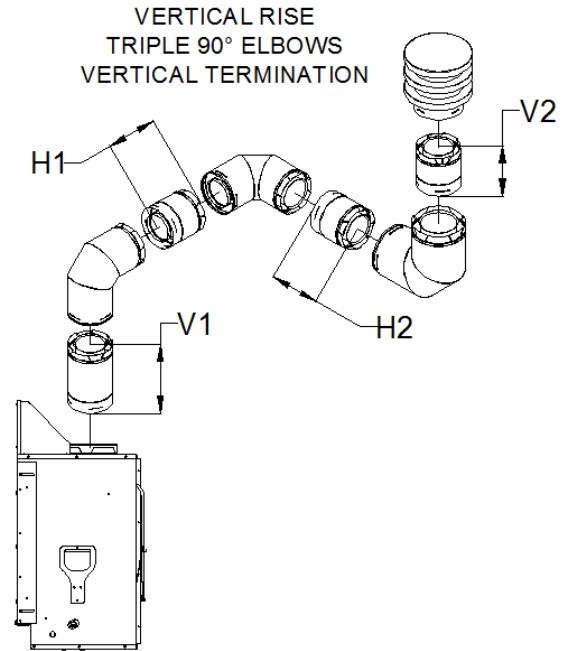

### **VERTICAL THROUGH-THE-ROOF VENTING USING FOUR 90° ELBOWS**

In extreme situations, Four 90° elbows may be required to reach a proper exit point for the vent system. Mendota has spent considerable time and effort in the design of this fireplace and its venting system. Through this effort, Mendota has been able to certify the use of Four 90° elbows.

The use of Four 90° elbows must meet some minimum prerequisites.

Prerequisite #1: The vent system must terminate vertically using a vertical vent cap.

Prerequisite #2: There must be a minimum 12 inches of vertical starter section connected directly to the top of this fireplace.

Prerequisite #3: For vertical starter sections less than 4 feet tall, you must reduce 6 feet off the maximum horizontal run allowed per Master Flue Venting Requirements Chart.

## ML39 DOOR OPERATION

### To Remove Door

Use the glass latch tool to disconnect the spring latches from the glass frame. Insert tool into hole in latch, pull towards you and Rotate 90 degrees to disengage top latches. Remove tool. There are two spring latches on top of this gas fire-place.

With both hands, rotate top edge of glass frame away from unit 8 inches. Lift glass frame up 1 inch, at an angle, and move away from unit. Door is now free from unit.

### To Replace Door

Identify small tabs that protrude downward on the bottom left and right corners of glass frame. Identify a rectangle slot on the bottom right and left corners of firebox opening sides.

Carefully line up the bottom corner tabs in glass frame bottom corners with slots in firebox bottom left and right corners. Insert tabs into slots and center glass frame over firebox, left to right.

After door has been placed into slots, rotate door towards firebox until gasket seal is touching the firebox frame.

Use the tool provided to connect the spring latches to the glass frame. Insert tool into hole in spring latch, pull latch towards you, rotate latch so the hook is facing downward then release latch to hook to door frame.

Door is now connected and sealed to unit.

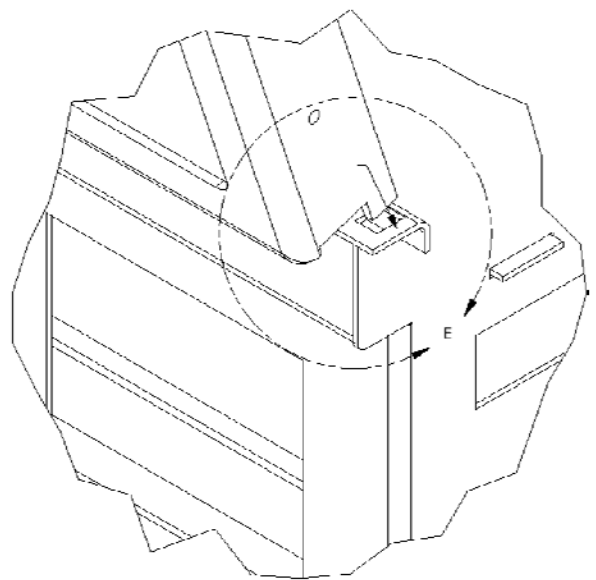
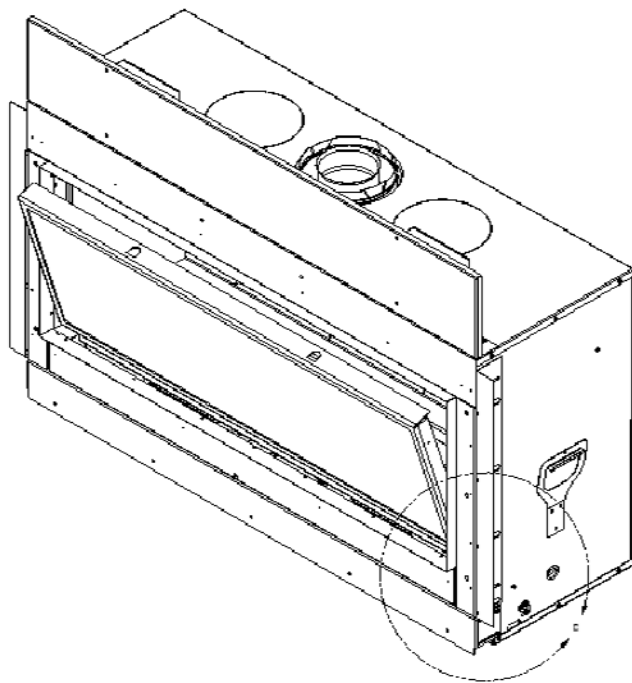
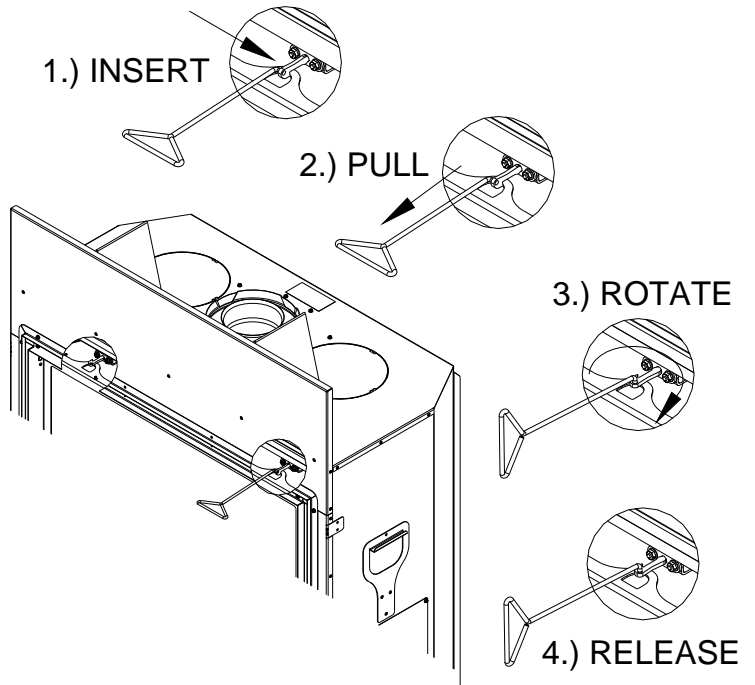

## LOCATION OF MASTER SWITCH AND SYNC SWITCH

The Master Switch and Sync Switch are located 6-3/4" to right from the left edge of the glass frame and under the bottom edge of the glass frame in the bottom air gap.

Use the glass latch tool to actuate the two switches.

The Master Switch must be ON for the pilot flame and burner flames to activate.

The SYNC switch is to be used initially when mating the remote transmitter with the receiver located within this appliance body. Sync switch use is not necessary during remote transmitter battery replacement. The receiver will continue to remain synced to the original transmitter even if battery power is removed from the remote transmitter.

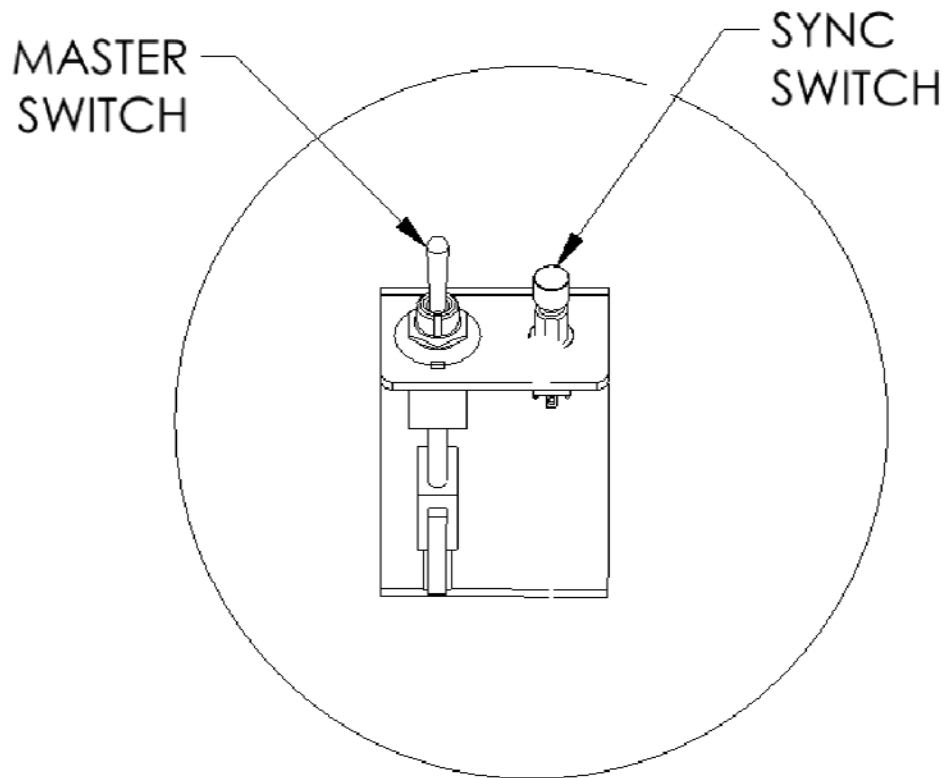

## BEFORE YOU BEGIN

Read this entire manual before you use your new fireplace (especially the section “Safety Precautions” on page 2). Failure to follow the instructions may result in property damage, bodily injury, or even death.

## REMOTE CONTROL TRANSMITTER FUNCTIONS

**NOTE:** The Wall Receiver will “beep” once every time a Remote Transmitter Key is pressed, signaling that the command has been received.

Identify the four function buttons on the Remote Transmitter:



**On/Off Key:** This button turns the system ON or OFF. When this button is pressed and the system is OFF, the pilot light will stay ON if the “Standing Pilot Switch” is in the ON position.



**Thermostat Key:** This button, when pressed after the ON/OFF KEY is pressed and the system is ON, will allow the selection of three modes: Manual Operation, Normal Thermostat and Smart Thermostat.

**Manual Mode:** In this mode, the room temperature is ignored and the fireplace can be turned ON indefinitely. The room temperature rise has no effect on this mode. All other functions such as fan speed control, flame height control, secondary burner On/OFF control and Accent Light ON/OFF controls will be manually controllable.

**Normal Thermostat:** In this mode, the fireplace will stay functioning until the room temperature increases 1°F above the Set Point Temperature. To increase the Set Point Temperature, Press the UP button until the desired temperature is displayed in the SET POINT TEMPERATURE window. The fan will turn on 5 minutes after fireplace startup and will turn off 12-1/2 minutes after the flames turn off, in this mode. The flame height can be adjusted while the fireplace is functioning, fan speed can be adjusted after 5 minutes of startup. Secondary burner can be turned On or Off at any time after startup. The Accent Light can be turned on or off any time after startup.

**Smart Thermostat:** In this mode, all other functions except the flame height adjustment are allowed. Manual flame height adjustment is not allowed in this mode. The Smart Thermostat function adjusts the flame height in accordance to the difference between the set point temperature and the actual room temperature. As the room temperature gets closer to the set point temperature, the Smart Function automatically modulates the flame down.



**Up/Down Key:** This key is used to increase or decrease the Set Point Temperatures, Flame Height and Fan Speed and to toggle between Accent Light ON/OFF and Secondary Burner ON/OFF.



**Mode Selection Key:** This key is used to toggle between the various function icons : Flame Height, Fan Speed, Accent Light and Secondary Burner.



Fig. 1: PROFLAME Transmitter.

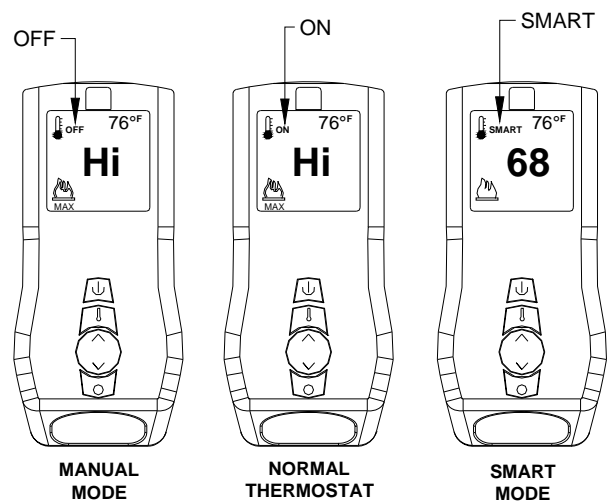

# REMOTE TRANSMITTER OPERATING INSTRUCTIONS

## TO TURN ON THE APPLIANCE:

Press the ON/OFF button. The transmitter display will show all active icons on the screen. Select the Thermostat Mode by pressing the Thermostat Key: OFF (meaning Manual Mode), ON (meaning normal Thermostat) or Smart (meaning Smart Mode). In OFF (Manual Mode), the appliance will ignite and start on HI. In ON (Normal Thermostat Mode), the appliance will only ignite if the Set Temperature is greater than the Room Temperature. In SMART (Smart Mode), the appliance will only ignite if the Set Temperature is greater than the Room Temperature.



TO TURN OFF THE APPLIANCE, press the ON/OFF button.



**Mode Key:** Pressing the MODE KEY toggles between the various available functions: Flame Height, Fan Speed, Accent Light Dimmer and Secondary Burner On/Off.



FLAME HEIGHT

**Flame Height:** 6 flame height Levels are available. While the Flame Height Icon is displayed, pressing the Up or Down button once will increase or decrease the flame height by 1 of 6 increments. If the flame height is at Level 1 and the Down button is pressed, all burners will turn OFF. If in IPI mode, the pilot light will also extinguish. If in Standing Pilot Mode, the pilot light will remain ON. Note: If in SMART model, the flame height function is not available for manual adjustment. In SMART mode, the flame height regulates automatically.



Flame Off

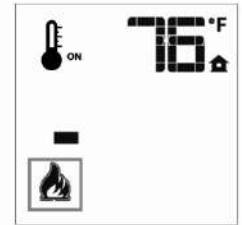

Flame Level 1

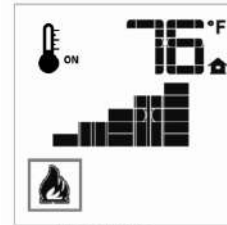

Flame level 5



Flame Level Maximum



FAN SPEED

**Fan Speed Control:** The fan speed can be adjusted through six (6) speeds and OFF. To activate this function, press the MODE Key to index to the fan control icon. Use the UP/Down Arrow Key to turn ON, OFF or adjust the fan speed. A single “beep” will confirm reception of the command. Once you set the desired fan control, the system will remember your selected fan speed until you manually change it.

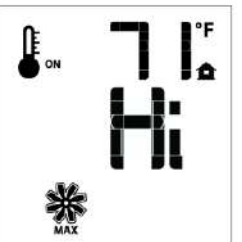
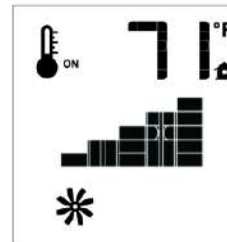

**Accent-Light Dimmer:** This function controls the Mendota Accent Light functions. Pressing the UP key in this mode will TURN ON the Accent Light and allow you to control the brightness of the Accent Light in 6 steps. A single “beep” will confirm reception of the command. Once you set the desired light brightness, the system will remember your selected brightness level until you manually change it.

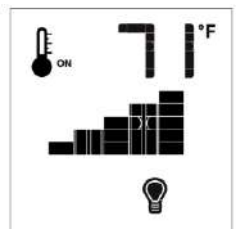

2nd BURNER

**Secondary Burner:** This function controls the Secondary Burner's ON/OFF feature. Pressing the UP Key in this mode will TURN ON the Secondary Burner and Pressing the DOWN Key will TURN OFF the Secondary Burner. The flame level will not change when you turn the Secondary Burner On or Off. The flame level can only be changed in the Flame Level mode.

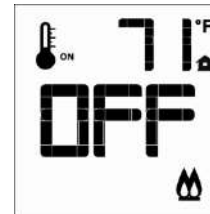

### **Temperature Indicator (°F or °C)**

Press the ON/OFF Key and Turn Off the Fireplace.

Simultaneously, Press both the MODE Key and the Thermostat Key.

Look at the LCD display to verify that your desired indicator (°F or °C) is being displayed. If not, repeat step 2.

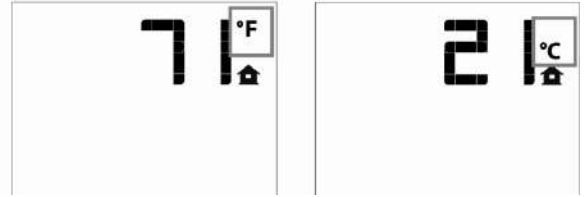

### **Key Lock Function**

To prevent unsupervised children from operating the fireplace, a KEY LOCK function is provided with this remote control system. To activate the KEY LOCK function, simultaneously press the "MODE KEY" and the "UP KEY". To deactivate the KEY LOCK function, simultaneously press the "MODE KEY" and the "UP KEY".

During KEY LOCK mode, none of the Keys will function. You must DEACTIVATE the system before you can use the Remote Transmitter.

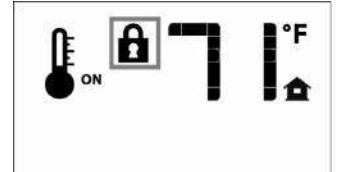

### **Low Battery Power Detection**

**Transmitter Batteries:** The life span of the remote control transmitter batteries depends on various factors: quality of the batteries used the number of ignitions of the appliance, the number of changes to the room thermostat set point, etc. When the Transmitter batteries are low, a Battery Icon will appear on the LCD display of the Transmitter before all battery power is lost. When the batteries are replaced, this icon will disappear.

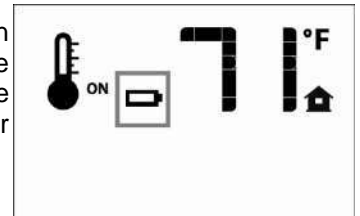

### **Operating During Power Outages**

This electronic ignition system utilizes the supplied 110VAC power when it is available for all functions of this system. If the AC power is interrupted during a power outage, plug in the battery pack (supplied with this fireplace) to the Fireplace Backup Power Inlet Port installed on the wall to the left side of the fireplace (located about 18" up from floor level).

During the power outage, the appliance's burners will function. In addition, Flame Height adjustment and Secondary Burner ON/OFF functions will be available. The Fan and Accent Light, which are wholly dependent on 110VAC power, will not function.

This appliance is designed and tested to be operated during power outages. The overall efficiency of this appliance will be reduced by approximately 5% when the blower function is disabled during the power outage period.

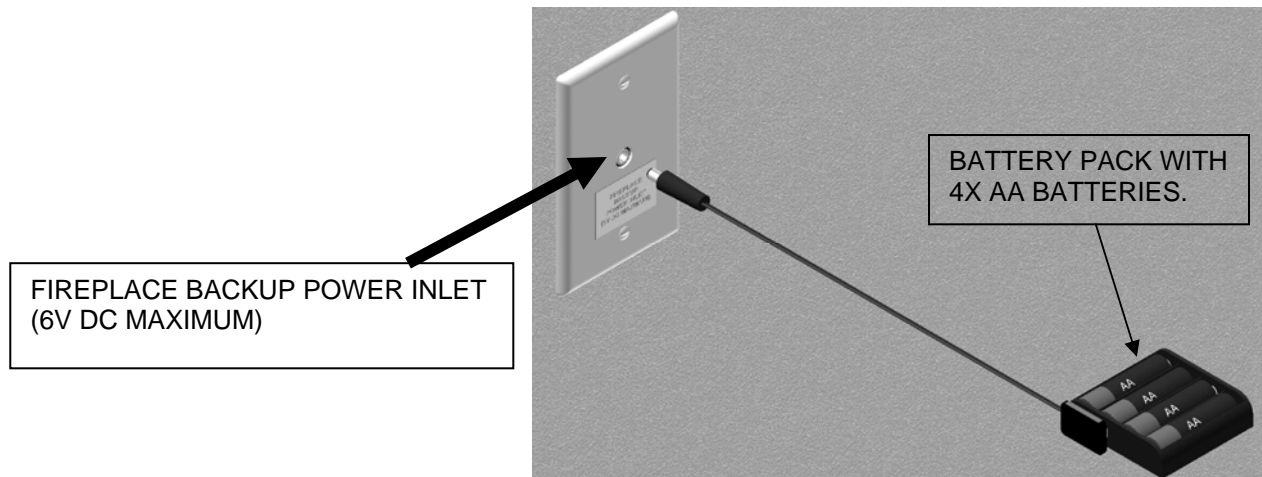

## **“FIRST TIME” PILOT LIGHTING INSTRUCTIONS**

**IMPORTANT:** Be sure all items on "INSTALLATION CHECK OFF LIST" in the Installation Manual have been completed!

**CAUTION:** If the pilot goes out, be sure to wait a minimum of five minutes before attempting to relight the pilot. Make certain that any manual gas supply shut-off valves located upstream of fireplace are open and the Master On/Off switch is toggled to the ON position.

Make certain that 110VAC power is connected to Electrical Junction Box on left side of Fireplace and that the Electrical Power is "ON".

Insert Batteries in the Remote Transmitter. Note the polarity of batteries and insert as indicated on the battery compartment cover.

For the "First Time Lighting", Remove the Glass Door. This is required to purge the gas line of air and to inspect the pilot lighting spark.

Press OFF on the remote Transmitter. Press MODE button on Transmitter. Press UP for "CPI" (standing pilot mode). Press MODE button again to exit. You will hear a series of clicks and after a few seconds, you will hear sparking at the pilot spark electrode.

Allow adequate time for the air in the gas-line to purge. The control system will stop sparking after 30 seconds if the pilot light does not light. After a 30 second delay the control system will start sparking again for 30 seconds more. If the pilot light does not light after the third 30 second spark event, the system will enter "Lock-out" mode. To unlock from "Lock-out" mode, Press the ON/OFF button on Transmitter then Press ON/OFF button on the transmitter again so the Transmitter display turns off. Wait 30 seconds. Turn OFF the Master Switch. Wait 30 seconds and Turn Master Switch ON again. Repeat this sequence until the pilot flame lights and the pilot is burning steadily.

Once the pilot flame is lit and well-established, close glass door.

**WARNING:** NEVER IGNITE MAIN BURNERS WITH GLASS DOOR REMOVED OR OPEN. Doing so will lead to damage to pilot flame sensor and spark electrode wire leads.

Press the ON/OFF button on Transmitter to "ON". All burners should ignite and run at "high-fire". Toggle through other functions of the Fireplace (Flame Height, Fan Speed and Accent Light brightness) to verify all functions.

Perform gas inlet and outlet pressure tests and leak tests on field installed gas fittings and factory installed fittings in the gas valve compartment, at this time. Note: Burners must be ON to check outlet pressures and to leak test gas train fittings upstream of main gas valve.

### **Initializing The Remote Control System**

**MASTER SWITCH:** Remote Transmitter WILL NOT communicate to receiver unless the Master Switch is ON. The master switch when OFF disable all functions and acts as a Master Safety Shutoff Switch.

(Synchronizing Receiver and Transmitter)

Master Switch and Sync Switch are located at the bottom left corner of the Glass Frame.

Toggle Master Switch to ON (pull toward front of unit). Remote Transmitter WILL NOT communicate to receiver unless the Master Switch is ON.

Locate Sync Switch (directly above Master Switch). Press the Sync Button. The receiver will beep 3 times indicating that it is ready to synchronize with a Remote Transmitter.

Push the "ON" key on the Remote Transmitter. The receiver will beep 4 times to indicate that the Transmitter's command is accepted and sets to the particular code of that Transmitter. The system is now initialized.

**NOTE:** Once synchronized, the Transmitter and Receivers will communicate permanently and no further Synchronizing steps are necessary unless either the Transmitter or Receiver is replaced.

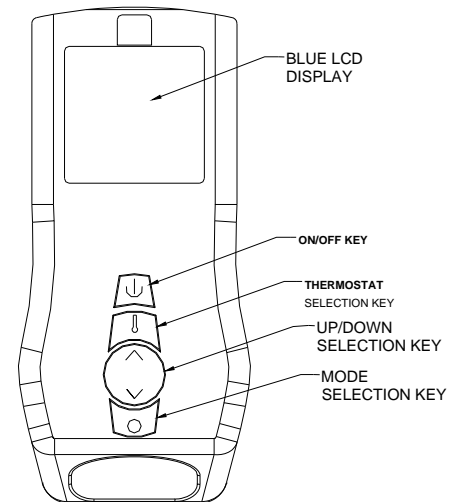
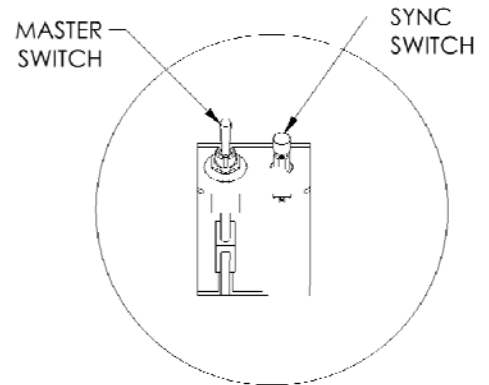

**REMOTE TRANSMITTER**

## IPI/STANDING PILOT SYSTEM INFORMATION

	REMOTE CONTROL	WALL RECEIVER
Supply voltage	4.5V (three 1.5V AAA batteries)	6.0V (four 1.5V AA batteries)
Ambient temperature ratings	32 – 122 °F (0 – 50 °C)	32 – 140 °F (0 – 60 °C)
Radio Frequency	315 MHz	315 MHz

### ATTENTION!

The transmitter and receiver are RADIO FREQUENCY DEVICES. Placing the receiver in or near metal may severely reduce the signal range.

Turn off the main gas supply of the appliance during installation or maintenance of the receiver.

Toggle the Master Switch to OFF during installation or maintenance.

Turn “off” main gas supply to the appliance prior to removing or reinserting the batteries in the receiver.

During appliance installation/maintenance or in case of remote control malfunction, turn off electrical supply to this appliance and disconnect the Backup batteries from the wall DC connector. Contact technical service.

### Intermittent Pilot Light and Standing Pilot Light Features

This gas fireplace is equipped with an electronic ignition System that first lights a pilot light then uses the pilot light to ignite the main burners. The pilot light can be set in the CPI (Standing Pilot) mode to allow the pilot light to remain on indefinitely by setting the Remote Transmitter to CPI mode. If the remote transmitter is set to the IPI (Intermittent Pilot) mode, the pilot light will only light and remain ON while the main fireplace burners are operating.

**IPI Mode:** This mode turns the pilot light “OFF” when the fireplace is not functioning and only lights the pilot light automatically when a call for heat is made by the remote control.

**(CPI) Standing Pilot Mode:** If set to CPI Mode, the pilot light will ignite and remain ON at all times.

### Setting To IPI versus CPI Mode:

With the remote transmitter OFF, press the MODE button. You will see either “CPI” or “IPI” displayed on the transmitter screen. Press the UP arrow button to set “CPI” mode and press the DOWN arrow button to set “IPI” mode. One set to the desired setting, press On/Off button to activate the fireplace.

**NOTE:** Mendota Fireplaces recommends that the (CPI) Standing Pilot Mode be used during the winter months when the average daily high temperature falls below 50°F. This will keep the fireplace chimney heated for proper updraft during burner ignition and it will also eliminate excessive condensation of exhaust vapors on the door glass. Further, leaving the fireplace in the Standing Pilot Mode will keep the fireplace body warm and eliminate cold drafts and heat loss to the cold air that is trapped inside the firebox.

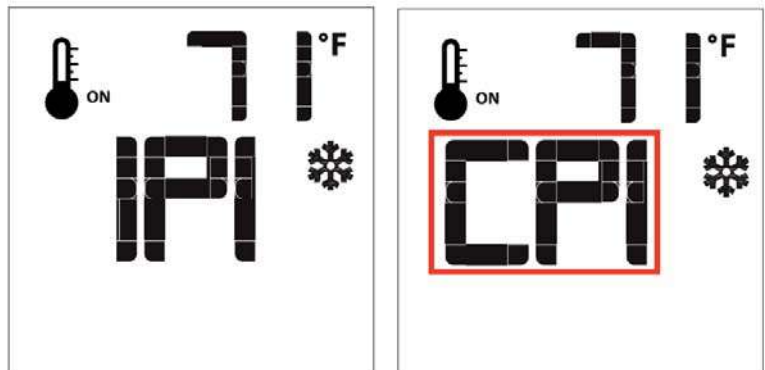



## **OPTIONAL BURNER MEDIA KITS**

### **Introduction:**

The Optional Burner Media available for the Mendota ML-39 are designed and created to be heat resistant when placed directly on top of the main burner. Different media types may be mixed together to create attractive presentations.

**WARNING:** Never use media that is smaller than 1/2" diameter. Do not use common crushed glass media. Common soda lime glass is not heat resistant and will discolor and break apart. This can result in the burner ports being plugged which can lead to poor combustion, poor flame presentation and possible delayed ignition hazards.

**HINT:** The flame appearance shapes and flame color quality change dramatically with the amount of base media placed on top of the burner and media placed over the combustion air slots behind the burner and in front of the burner. Flame appearance is always better if sparse media is used.

### **Burner Top Color:**

To provide for extended burner lifetime, the burner top material is selected to be 304 Stainless Steel. High temperature powder paint or liquid spray paint do not adhere to 304 Stainless Steel readily. For this reason, the burner top is left bare and unpainted. If you wish, you may use Stove Bright High Temperature Spray Paint to touch up the burner top, while understanding that the paint may only temporarily remain on the burner. This is strictly a cosmetic option that you may use.

### **Installation Instruction:**

1. Install the burner floor plate (Burner Airbox) and one Panoramic Curved Liner inside the firebox per instructions included with the Panoramic Curved Liner Kit.
- a) Glass Media (3/4" diamond clear, 3/4" diamond black, 1/2" diamond clear, 1/2" round clear, 1/2" round black): You may mix different size, shape and different color glass media. Spread liberally over the top of the burner but very sparingly over the combustion air slots located behind and in front of the burner. Attractive combination options are:
  - I. A base layer of 3/4" clear diamond with a 2-3 inch wide second layer of 1/2" diamond clear on top.
  - II. A base layer of 3/4" black diamond with a second layer of 1/2" diamond randomly dispersed as a second layer.



- b) Natural Rock Media: Spread randomly over the top of the burner but very sparingly over the combustion air slots located behind and in front of the burner. Create random multi level layers with large rocks on top in random colors and in random positions.



- c) Natural white tumbled marble: Spread randomly over the top of the burner but very sparingly over the combustion air slots located behind and in front of the burner. Create random multi level layers with rocks in random positions.



# FOREST OAK TWIG SET INSTALLATION INSTRUCTIONS

## Parts Identification Diagrams

Open the box and, very gently and carefully, pull out the three foam packages and lay on the floor.

Use a utility knife to cut tape strips that secure foam package tops to foam package bottoms. Lift off foam package top very slowly and carefully. If you find that the foam package upside down, reverse it before attempting to separate the top and bottom foam trays.

It is of the utmost importance that you treat every package and every twig piece and assembly like you would an egg. Breakage is your responsibility and is not covered by a Warranty Policy.

The diagrams, below, show all the parts included with this Twig Set. *Right Side Twig Assembly has brown colored bark on the bottom right corner and Left Side Assembly has brown colored bark on the bottom left corner.*

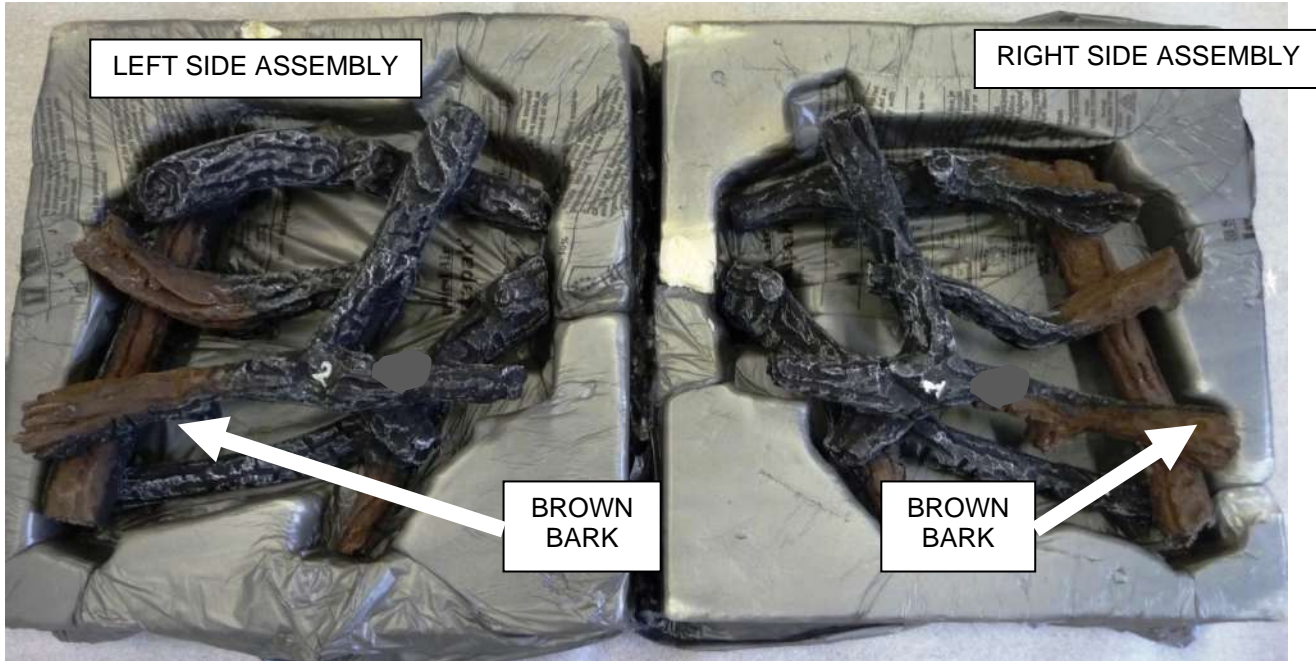

## **INSTALLATION INSTRUCTIONS:**

**CAUTION:** The log pieces are fragile. Exercise extreme care when opening the log set package and removing individual log pieces.

### **Introduction:**

The Forest Oak Twig Log Set is designed and created to replicate a natural burnt twig pile. The colors selected include black shades, grey shades, brown shades and red shades.

**Optional Base Media:** The twig set includes a bag of “super black” coals. You may, however, pair the twig set with the Natural Rock Kit, White Marble Rock Kit or other glass media. It is up to the homeowner to select the desired cosmetic effect. Coals are included with the twig set but other Base Media Kit(s) are not included with the Twig Log Set and must be purchased separately.

**Note:** In these instructions, the standard coal media is shown. The same installation procedures apply to other base media types selected.

**HINT:** The flame appearance shapes and flame color quality change dramatically with the amount of base media placed on top of the burner and media placed over the combustion air slots behind the burner and in front of the burner. Flame appearance is always better if sparse media is used.

### **Burner Top Color:**

To provide for extended burner lifetime, the burner top material is selected to be 304 Stainless Steel. High temperature powder paint or liquid spray paint do not adhere to 304 Stainless Steel readily. For this reason, the burner top is left bare and unpainted. If you wish, you may use Stove Bright High Temperature Spray Paint to touch up the burner top, while understanding that the paint may only temporarily remain on the burner. This is strictly a cosmetic option that you may use.

### **Sooting Potential on Log Pieces:**

Soot can form on log pieces if the yellow color zone of the burner flame impinges directly underneath twig pieces. The three main twig assemblies must remain flat on the burner top. Raising the twig assembly upward and away from the burner surface will result in some twigs of the assembly sitting in the yellow zone of the burner flames and may result in soot deposits in those areas.



**Installation Instruction:**

2. Install the burner floor plate (Burner Airbox) and one Panoramic Curved Liner inside the firebox per instructions included with the Panoramic Curved Liner Kit.
3. Place "Middle Twig Assembly" directly in the middle of the burner and its left rear end touching the rear wall of the Panoramic Curved Liner.

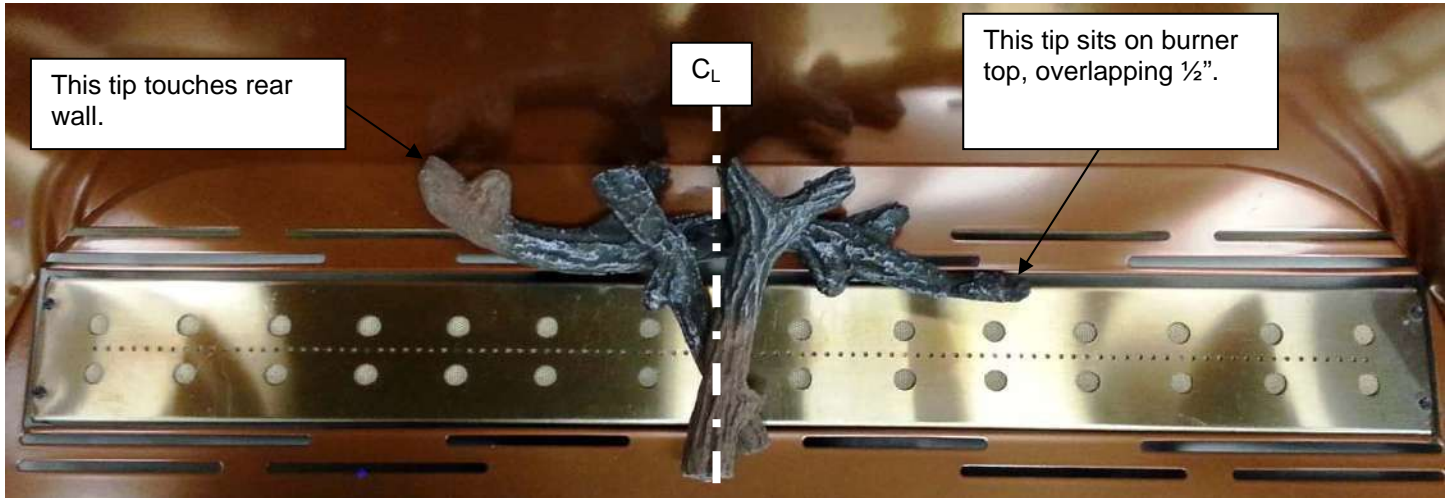

4. Place "Left Side Assembly" on the left side of burner as shown, below. This assembly has legs that sit directly on top of the burner and floor plate.



5. Place "Right Side Assembly" on the right side of burner as shown, below. This assembly has legs that sit directly on top of the burner and floor plate.



6. The three assemblies shall be positioned relative to one another as depicted, below.



7. Place Individual Twig Pieces #1, 2 & 3, as shown below.

- a) Twig #1 sits on the flat floor in front of the front end of Middle Assembly.
- b) Twig #2 sits on top of flat floor at its left end and on top of Middle Assembly at its right end.
- c) Twig #3 sits on top flat floor at its right end and on top of Middle Assembly at its left end.



- 8. Spread Coals in the open areas loosely and in one single layer on top of the burner in the middle open area between the two twig assemblies and also a few pieces on other areas of the burner under the twig assemblies. Avoid packing coals tightly.
- 9. You may brush inswool over twig pieces and coals for a dramatic glow effect. Use inswool liberally. Use a stiff nylon bristle cleaning brush; pinch a bundle of inswool in a tight ball in one hand and brush across top of inswool ball to break off inswool fibers over the burner areas, twig pieces and coals.

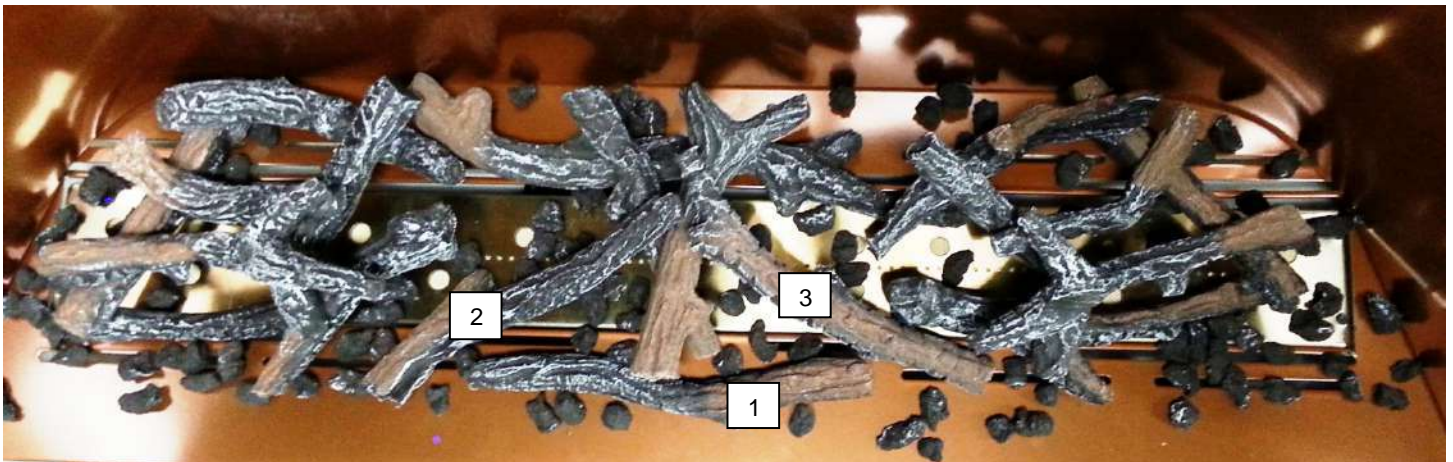

**LP Specific Hints:**

- 1. Make certain burner air shutter is fully open.
- 2. If soot deposits on the Twig Piece, place coals on large burner ports that are located directly below the sooting spots.

## **DRIFTWOOD LOG KIT INSTALLATION INSTRUCTIONS**



**Caution:** The log pieces are fragile. Exercise extreme care when opening the log set package and removing individual log pieces.

### **Introduction:**

The ML-47 Driftwood Log Set is designed and created to replicate naturally weathered wood. The colors selected include black shades, grey shades, brown shades and green moss shades. The moss growth is replicated in certain recessed areas of each log piece.

### **Optional Base Media:**

The driftwood set may be paired with Natural Rock Kit, Coals, White Marble Rock Kit or other glass media. It is up to the homeowner to select the desired cosmetic effect. Base Media Kit(s) are not included with the Driftwood Log Set and must be purchased separately.

**Note:** In these instructions, the Natural Rock Kit is shown. The same installation procedures apply to other base media type selected.

**Hint:** The flame appearance shapes and flame color quality change dramatically with the amount of base media placed on top of the burner and media placed over the combustion air slots behind the burner and in front of the burner. Flame appearance is always better if sparse media is used.

### **Burner Top Color:**

To provide for extended burner lifetime, the burner top material is selected to be 304 Stainless Steel. High temperature powder paint or liquid spray paint do not adhere to 304 Stainless Steel readily. For this reason, the burner top is left bare and unpainted. If you wish, you may use Stove Bright High Temperature Spray Paint to touch up the burner top, while understanding that the paint may only temporarily remain on the burner. This is strictly a cosmetic option that you may use.

### **Sooting Potential on Log Pieces:**

Follow specific instructions provided to cover the large burner holes with Base Media. Failure to do so can result in soot formation on log pieces if the yellow color zones of the flames impinge directly underneath the log pieces. The instruction provided to block specific burner ports are intended to eliminate soot formation on the driftwood log pieces.



**Installation Instruction:**

1. Install the burner floor plate (Burner Airbox) and one Panoramic Curved Liner inside the firebox per instructions included with the Panoramic Curved Liner Kit.
2. Identify the Driftwood Log Pieces per diagram, below.

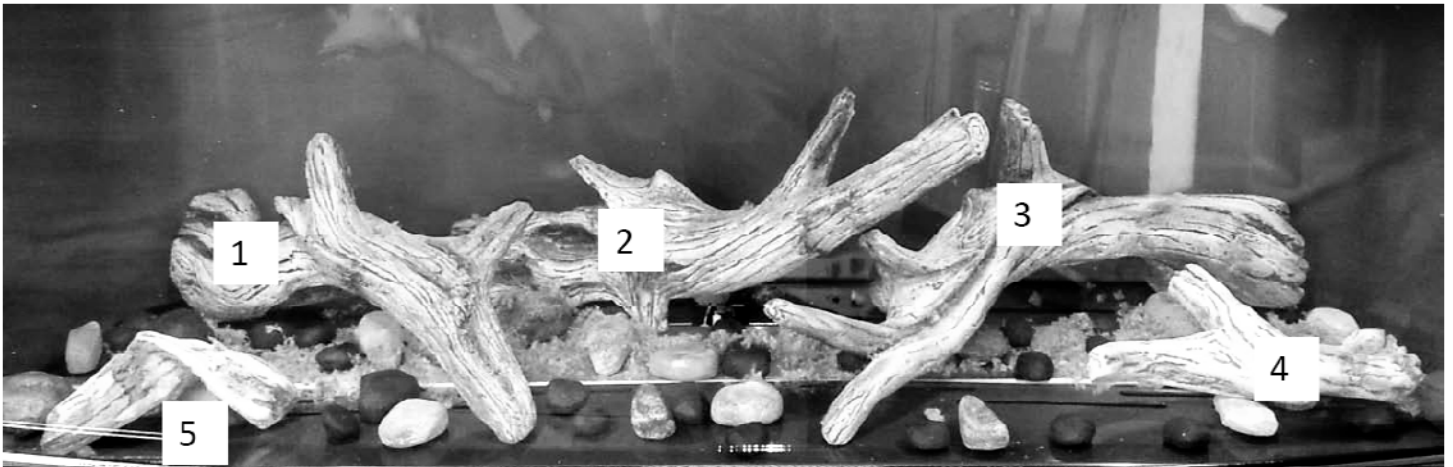

3. See diagram, below. Identify the large holes which are shaded in the diagram. Place one piece of base media directly over each of these holes. If using Natural Rock as base media, select smallest rock pieces and place them directly over the holes identified.

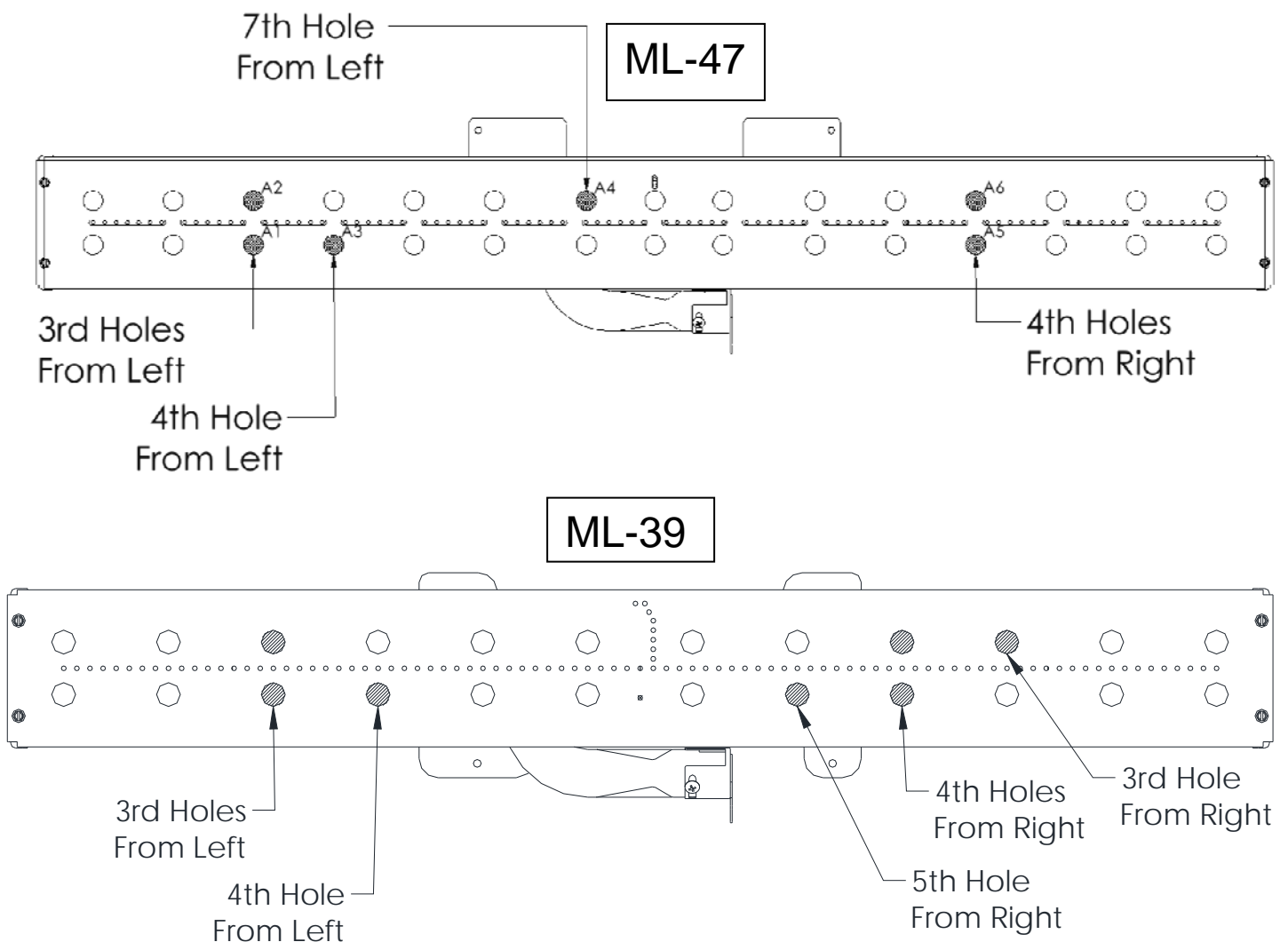

**Note:** Place Logs 1, 2 and 3 directly on the floor plate only. Do not attempt to place Logs 1, 2 or 3 on top of any base media. The logs are designed to sit directly on top of a flat surface.

- Place Log #2 in location shown, below. Left rear edge of Log #2 shall touch rear wall of the Panoramic Curved Liner and front right tip shall be about  $\frac{1}{2}$ " in front of rear edge of the burner. Left edge shall be approximately 8" from the left edge of the burner on the ML-47. On the ML-39 the left edge shall be approximately 5" from the left edge of the burner as shown below.

ML-47



ML-39

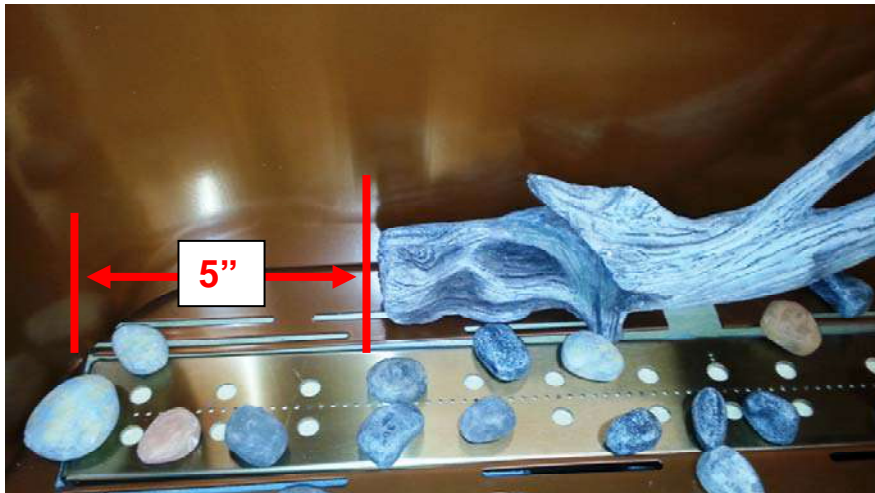

5. Place Log #1 with its left rear edge touching rear wall of panoramic panel and left edge touching the curved corner of the panoramic panel liner. Front right tip of Log #1 should sit in front of the front edge of the burner and in front of the combustion air slot.
6. Place Log #5 in front of the burner as shown, below. Log #5 may sit on top of Base Media as you desire and its left to right location is not critical. However, avoid placing Log #5 on top of burner ports.

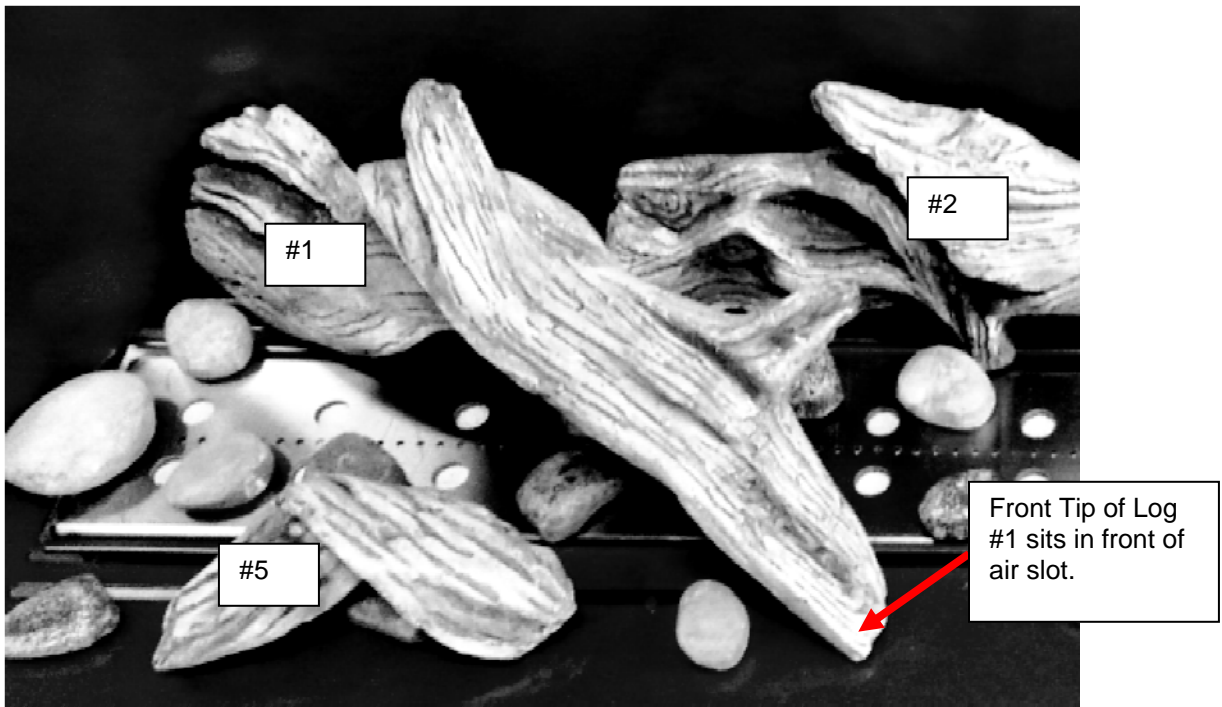
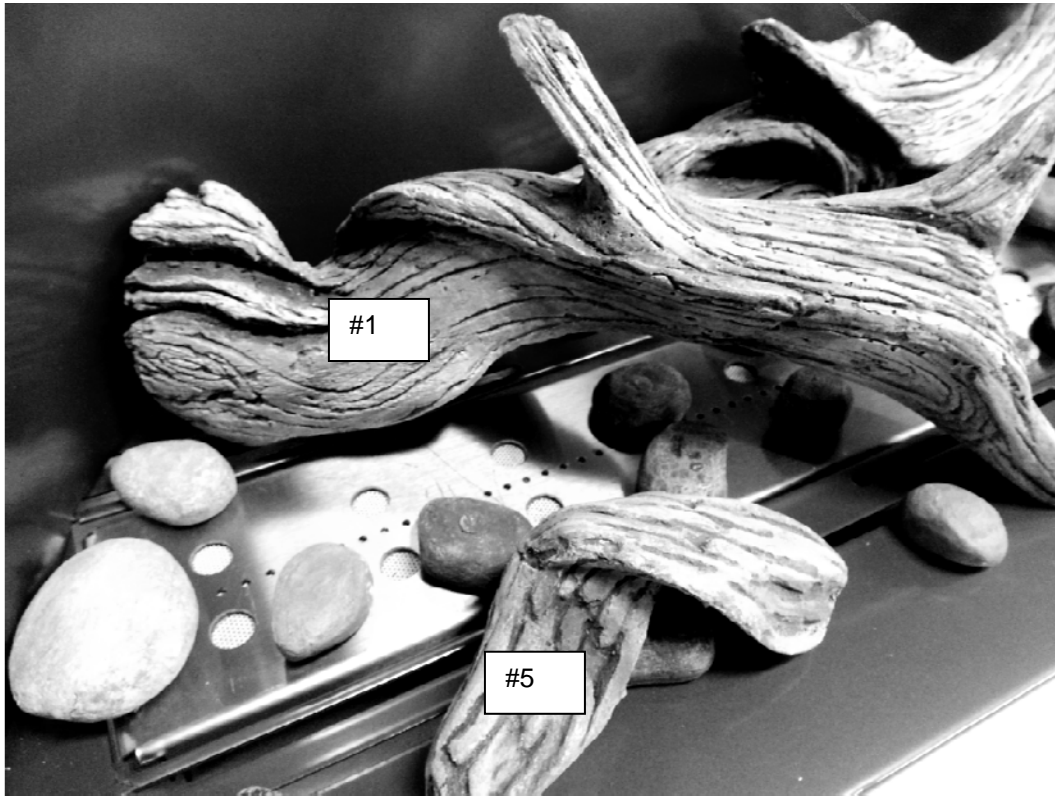

7. Log #3 sits as shown in the image, below. The right rear corner of Log #3 touches the curved right corner of the panoramic panel and the front left tip sits directly on top of the burner floor plate (Burner Airbox) approximately 1-3/4" in front of the front edge of the burner.



8. Place Log #4 in front of the burner as shown, above. Log #4 may sit on top of Base Media as you desire and its left to right location is not critical. However, avoid placing Log #4 on top of burner ports.
9. You may place Base Media randomly on top of the remaining burner surface. But do not pack media tightly. Leave large gaps between media pieces. You may place multiple layer of media on top of the burner, however, be aware that the flame appearance, flame height and flame color will vary depending media distribution. Definitely avoid blocking off air slots in front and rear of burner. You can sparsely distribute Base Media over air slots but majority of air slots must remain open to allow combustion air flow to the burner flames.
10. You may sprinkle inswool over Base Media and Burner Top loosely to gain glow effect and to hide burner surface, if desired.
11. Below is an example of how the Driftwood Presentation appears when complete.



## FLAME APPEARANCE ADJUSTMENT

### Air Shutter Adjustments

Be sure burner and burner media are positioned properly. For Natural Gas applications, air shutter shall be 1/8" open. For LPG applications, start with air shutter open to 3/8". After burner has been properly installed and operated for 20 minutes, small additional adjustments to the air shutter may be necessary for final flame appearance. These small shutter adjustments can be made by following these procedures:

**NOTE: Start with the burner air shutter set at 1/8" open for NG and 3/8" to 1/2" open for LPG.** Opening the shutter will yield shorter and blue(er) flames and closing the shutter will yield taller and yellow(er) flames.

The burner air shutter adjustment lever is located inside the firebox on the right side of center.

Install burner media and glass frame, and burn unit for 20 minutes minimum.

If flame is too "blue" open Air Shutters until flames turn yellow.

If flames are too "orange" or are causing sooting, open Air Shutters until flames begin to turn blue.

**NOTE:** If sooting does not stop, turn off fireplace & call a Mendota Service Person.

**IMPORTANT:** Try each new shutter setting for approx. 20 minutes before making additional changes.

**NOTE:** Changes in burner flame can be made by re-arranging the burner media as well. Make certain burner media is loosely spread over burner. DO NOT pack media tightly.

For NG applications, start with the burner air shutter closed to 1/8" open. For high altitude applications, air shutter may need to be open further.

For LPG applications, start with the burner air shutter open to 3/8". For high altitude applications, air shutter may need to be opened further.

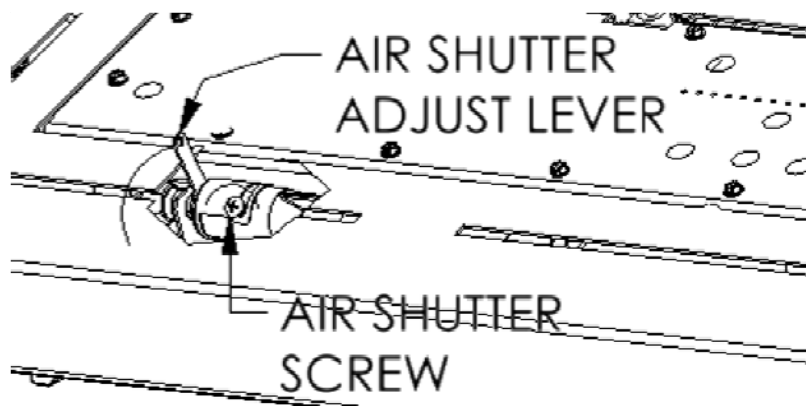

## **INSTALLATION CHECK OFF LIST**

The following Check-Off Lists must be completed prior to final operation of the Fireplace.

- |                          |   |
|--------------------------|---|
| <input type="checkbox"/> | Co-axial vent rigid pipe, wall vent cap or roof vent cap must be installed by a Mendota approved person in accordance with instructions. All joints must be secured, "twist-locked" and leak-proof. 1000°F sealant must be used on the inner pipe joints of all DuraVent pipe sections. |
| <input type="checkbox"/> | Horizontal or vertical vent cap must be installed "right-side-up" and tightly sealed to structure per instructions. Vent Caps must be Mendota approved.   |
| <input type="checkbox"/> | Proper exterior and interior clearances for vent systems and locations for wall vent cap/roof vent cap must be maintained.  |
| <input type="checkbox"/> | Carefully check for correct gas pressure, proper size gas lines and for gas leaks.  |
| <input type="checkbox"/> | 115 V electrical service and gas supply must be installed in accordance with instructions and local and national codes.   |

## **LIGHTING CHECK OFF LIST**

- |                          |  |
|--------------------------|--|
| <input type="checkbox"/> | All items on "Installation Check Off List" (see above) <u>must</u> be completed.   |
| <input type="checkbox"/> | Check for gas leaks and gas pressures prior to installing facing materials.  |
| <input type="checkbox"/> | Install fresh batteries in remote transmitter. Follow "Initializing the System for the first time" instructions to synchronize the remote control and the receiver.  |
| <input type="checkbox"/> | Check air shutter opening - 0" to 1/8" Nat. gas or 3/8" to 1/2" LP gas.  |
| <input type="checkbox"/> | Carefully follow all Lighting and Log Installation Instructions.   |
| <input type="checkbox"/> | Make certain that burner lights immediately. DO NOT proceed with operation unless burner cycles "on/off" without delays.   |
| <input type="checkbox"/> | Make certain that the flame is "stable" and does not "lift" off burner. If flame lifts off burner, turn unit off and check that all vent pipes are "twist locked" and leak proof, the vent cap is "right side up" and that 1000° Sealant has been used on the inner pipe joints of all DuraVent pipe sections. DO NOT proceed with operation if flame is "lifting off" burner. Note: Do not separate telescoping sections. They must be used as complete assemblies. |
| <input type="checkbox"/> | Make certain glass door is in proper closed position and "centered" in firebox opening.  |

## TROUBLE SHOOTING THE ML39 FIREPLACE & MAINTENANCE INFORMATION

SYMPTOM	PROBABLE CAUSES	CORRECTIVE ACTION
1. Thin black coating (soot) forms on viewing glass.	A. Incorrect gas pressure or improper orifice size.  B. Not enough combustion air. Air slots blocked off.	Have gas supplier check for correct gas inlet pressure (7" W.C. Nat. Gas; 11" W.C. LP Gas). If sooting continues, open air shutter on burner (see "Gas Flame Adjustment" below). If sooting still continues, shut off unit and call Mendota service person. <b>NOTE:</b> To clean glass - remove glass and wipe glass with cloth or paper towel.
2. Humming or whistling coming from Fireplace.	A. Normal operating noise.	Some noise is normal. It is caused by the gas supply flowing through the gas orifice. It is expected from any gas fireplace. Turning the Hi/Lo Knob on the control can reduce the noise. Turning down the flame will reduce the heat output of the unit.
3. A change in flame appearance or burner operation.	A. A change in gas pressure.  B. Vent system restricted.	Have your gas supplier check for correct gas 7" W.C. Nat. Gas; 11" W.C. LP Gas). If flame still needs adjustment see "Flame Adjustment" below. Clean out carbon, spider webs, lint, etc. from shutter area. Logs and burner. Check Vent Cap's AIR INTAKE and Exhaust OUTLET ports.

### **Over Firing Of Burner**

NEVER "over fire" units by adjusting gas pressure or drilling out the orifice to increase BTUH above nameplate specifications. Over firing can cause permanent damage to firebox and deterioration of parts and void warranty.

### **MAINTAINING CORRECT PILOT-FLAME, PILOT OUTAGE & RELIGHTING**

The pilot flame must be checked during initial installation and annually by a qualified Mendota Technician. This appliance utilizes Flame Rectification Technology. If the pilot flame is turned down too low, the flame sensor may not detect the pilot flame and the pilot light may not stay lit. Do not turn down the pilot light flame. Use the IPI mode instead during summer months.

### **Cleaning Viewing Glass**

The viewing glass should be cleaned periodically. Exterior glass surface may be cleaned with cleaner as desired. To clean interior surface of glass - use soap and water. **CAUTION:** Do not use oven cleaner to clean glass. Do not use any type of abrasive cleaner. Clean the glass only when it has cooled to room temperature.

**NOTE:** Additives that are put in gas (both natural and propane) to make it smell can be harmful to glass and can leave a white film deposit on the glass. This deposit can be removed with cleaners such as KEL KEM "Polish Plus" (part # 65-06-00455) or comparable product (contact your dealer).

In some cases (especially when burning propane) additives can cause "crazing" or etching of the glass. This is not a common occurrence. However, any "crazing" or etching of the glass is not covered under the warranty. The solution may be to change propane suppliers.

### **Sooting**

Sooting is caused by improper installation of media, vent system or improper primary air shutter operation. However, some small areas of soot deposits on media surfaces are deemed acceptable. If you observe signs of sooting on the door glass (usually a thin black film on the Fireplace viewing glass or on the outside of the home around the vent cap), the unit must be immediately turned off and the local Mendota dealer promptly informed. Mendota dealers will correct "sooting" problems, but Mendota and their dealers are not responsible for damage caused by excessive sooting that has not been immediately brought to their attention.

### **Operation During Power Failure**

This fireplace is designed to operate during power outages. Blowers and the Accent Light will not function during power outages. However, all burners will continue to function normally. Heat output will be reduced slightly without the blower functioning (approximately 5% less).

### **Gas Shutoff Procedures**

The planning and installing individual must plan for a local code approved Manual keyed gas shut off valve installation. Consult with your installer about specific procedures about emergency gas shutoff.

## **MAINTENANCE**

Annual maintenance of Mendota units is required. The following procedures must be performed each year by a Mendota approved service person. NOTE: Any adjustments to burner, pilot or burner media must be done by a qualified Mendota service person.

Clean all lint and dust build-up around the control. Inspect the condition of any wiring under the burner for melting or damage.

- A. Remove media and clean away any foreign matter (lint, Carbon, etc.) on the burner and pilot light body and base. Be sure the burner ports are "open". Clean the pilot for any Carbon deposits. Be sure logs are re-installed per instructions in this manual.
- B. Check condition of glass door gasket, gasket must seal tightly over firebox, replace if necessary.
- C. Periodically check to verify that the vent system and vent cap are open and free of blockage.
- D. Before re-installing glass, have qualified service person check the operation of the pilot and cycle the burner per LIGHTING INSTRUCTIONS. Be sure all items in LIGHTING and INSTALLATION "check off" lists are completed.
- E. The viewing glass should be cleaned periodically. Exterior glass surface may be cleaned with cleaner as desired. To clean Interior glass surface, use Kel Kem "polish plus" (part # 65-06-00455) or comparable product. Do not use oven cleaner or abrasive cleaners to clean glass. Do not clean when glass is hot.
- F. Periodic visual check of pilot flames is required. Pilot Flame must overlap Flame Sensor and burner ignition ports at all times.

Periodic visual check of main burner's rear and front flames is required.

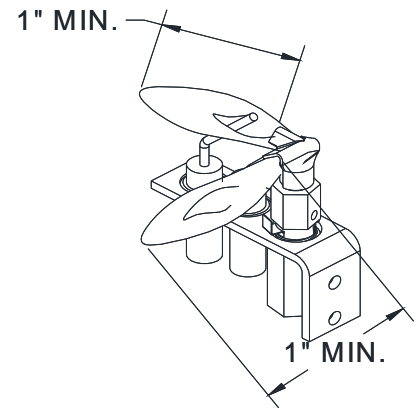

### **Burner Flames General Heights Reference Diagram**

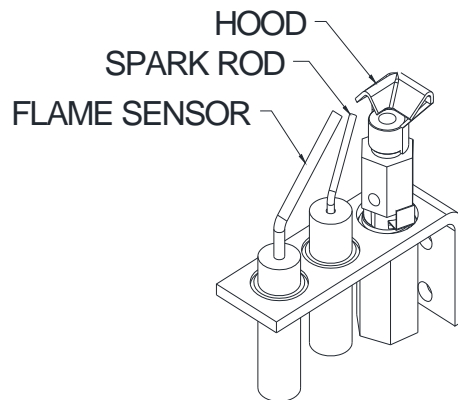



## Basic Maintenance

To access internal components for general service or maintenance requirements, remove any decorative front, remove the glass door, remove all burner media, inner Panoramic Lining and floor plate, remove main burner. Locate two access plates on the left and right side of firebox floor. See diagrams, below. Unscrew seven outer screws and lift entire left or right cover plate assembly which provides access to inner electronic components and gas train systems.

The left cover plate assembly provides direct access to the main electrical junction box and the main ignition module and wiring connections.

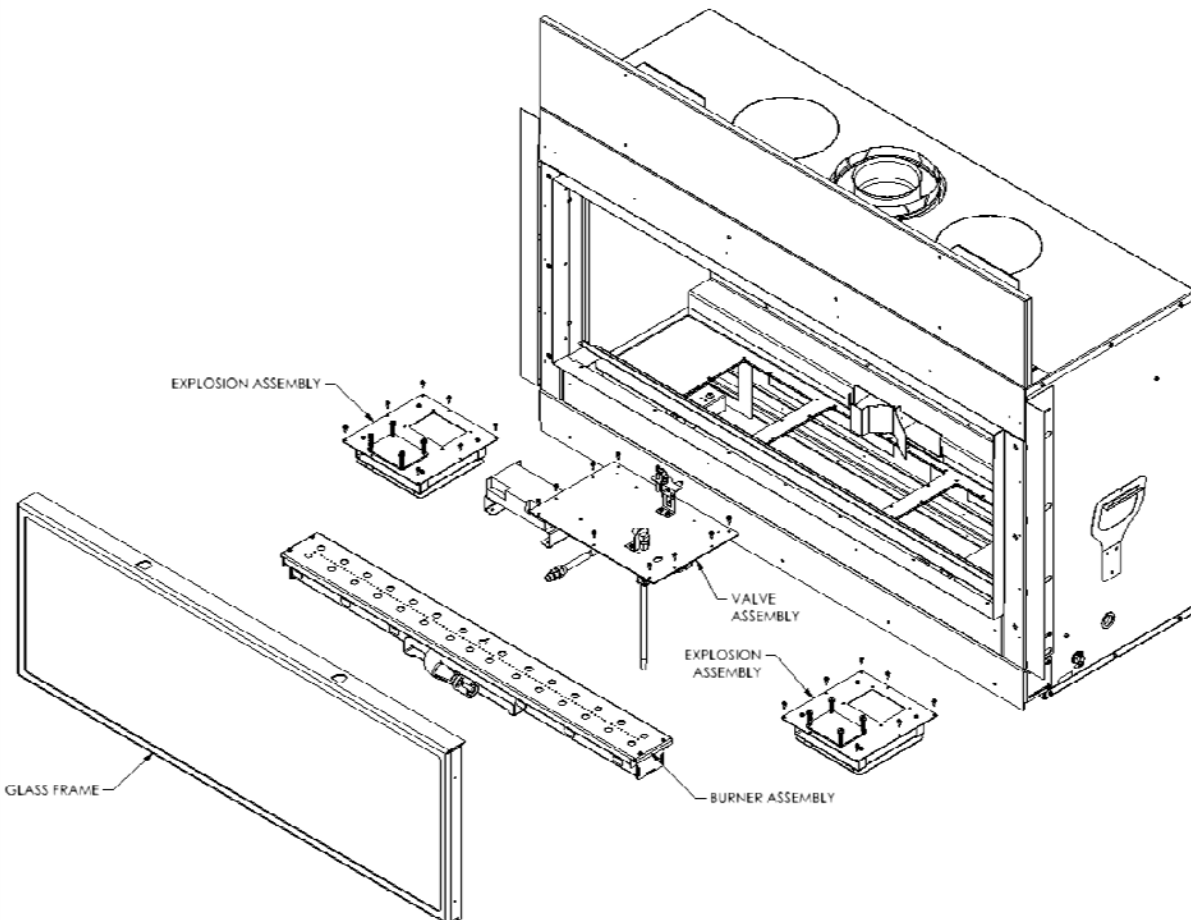
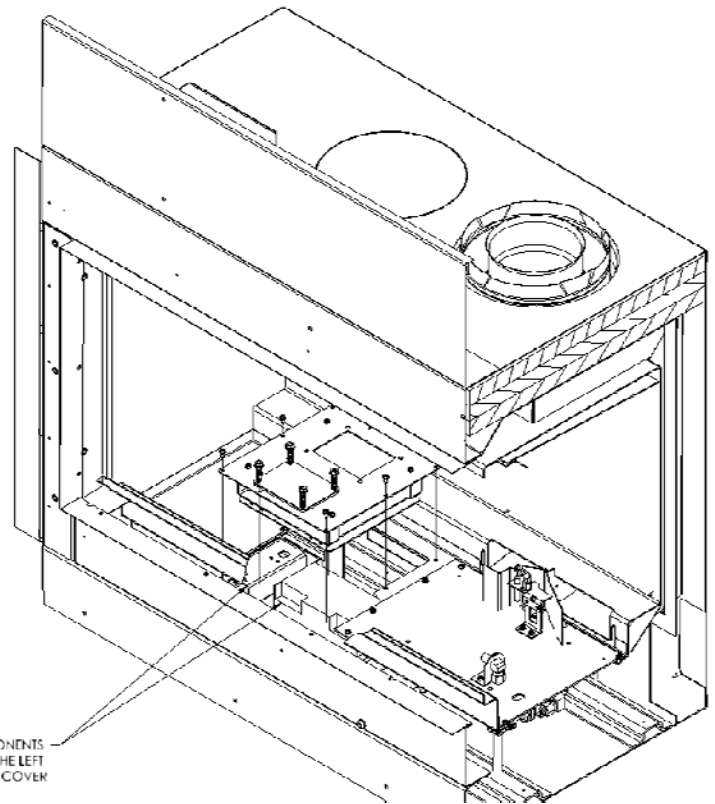

## NATURAL TO LP GAS CONVERSION

Kit #HA-96-00023 for Mendota Model ML39

This conversion kit shall be installed by a qualified service agency in accordance with the manufacturer's instructions and all applicable codes and requirements of the authority having jurisdiction. If the information in these instructions is not followed exactly, a fire, explosion or production of carbon monoxide may result causing property damage, personal injury or loss of life. The qualified service agency is responsible for the proper installation of this kit. The installation is not proper and complete until the operation of the converted appliance is checked as specified in the owner instructions supplied with the kit.

Cet équipement de conversion sera installé par une agence qualifiée de service conformément aux instructions du fabricant et toutes exigences et codes applicables de l'autorisés avoir la juridiction. Si l'information dans cette Instruction n'est pas suivie exactement, un feu, explosion ou production de protoxyde de carbone peut résulter le dommages causer de propriété, perte ou blessure personnelle de vie. L'agence qualifiée de service est esponsable de l'installation propre de cet équipement. L'installation n'est pas propre et complète jusqu'à l'opération de l'appareil converti est chèque suivant les critères établis dans les instructions de propriétaire provisionnées avec l'équipement.

**CAUTION:** The electrical supply to the fireplace must be turned off prior to performing the conversion. The gas supply must be shut off prior to disconnecting the electrical power.

### ORIFICE SIZES REQUIREMENT:

A Natural Gas to LPG conversion kit #HA-96-00023 must be installed to convert the ML39 Fireplace to burn LPG.

LP Conversion Kit #HA-96-00023 contains the following parts: One Motorized LP Pressure Regulator and one Cap Orifices **drill #50**.

### Recommended Procedure to Convert This Fireplace To Burn LPG

This fireplace arrives from the factory ready to burn Natural Gas. If you intend to burn LPG, it is highly recommended that you convert this fireplace and its Pressure Regulator, Pilot Orifice Slider Tab and Burner Orifice prior to placing this fireplace in its framed cavity.

See diagrams, on this page, and follow instructions to prepare this fireplace for conversion to LPG.

Remove the Burner by removing 2 screws in front of burner that secure burner weldment to firebox floor.

Remove front bottom cover plates below glass frame.

Identify the Pilot Light Hood, Main Burner Orifice and the Valve Pressure Regulator.

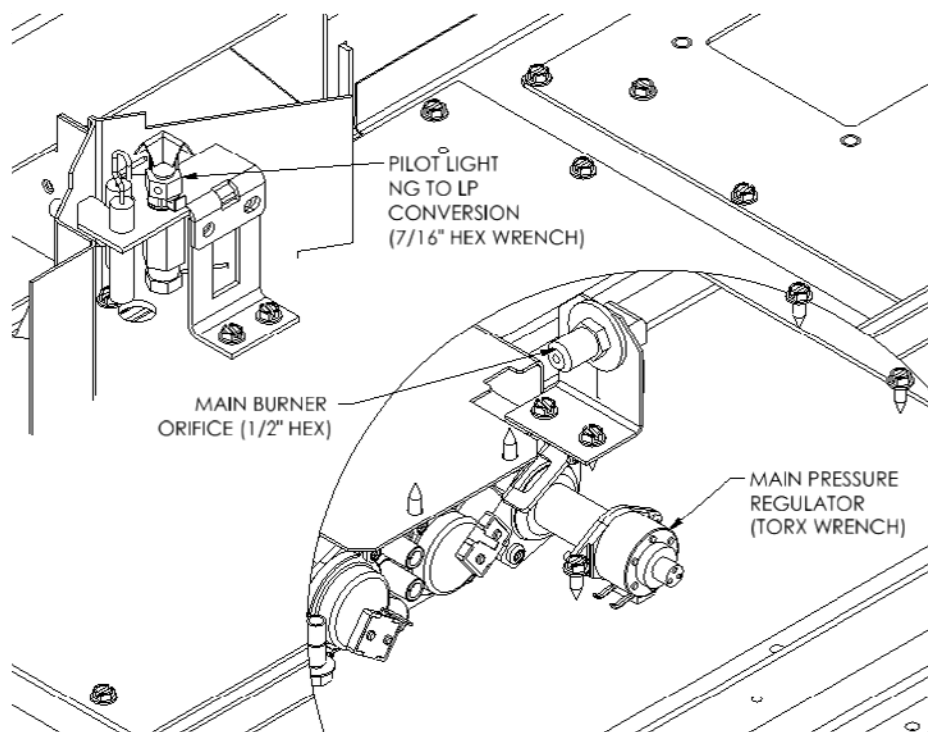

**WARNING:** It is of the utmost importance that the correct burner orifice be installed

Turn off gas supply at the appliance service valve.

See written instructions that accompany the LP pressure regulator.

1. Using a Torx T20 or a slotted screwdriver, remove 2 screws that secure the NG Pressure Regulator to the gas valve body and remove NG Pressure Regulator, see following page.
2. Install the new LP Pressure Regular onto the gas valve body in the same position and orientation as the NG Pressure Regulator you removed in Step 3, above. The LP Pressure Regulator can only be mounted in one position. Secure the LP Pressure Regulator in place. Tighten down.
3. Remove the Burner. Locate and Identify the Burner Orifice Spud. The Orifice Spud can be removed and installed using a 1/2" hex wrench.
4. **WARNING:** Make certain to Secure the Brass fitting and flex supply tube attached to the orifice in place using a 1/2" open end wrench before attempting to remove the burner orifice and also when installing and tightening the new LP orifice.
5. Install Burner Orifice #65-14-00050 (#50 drill) for the Main Burner. Tighten down securely.
6. Loosen Pilot Light's hex shape base using a 7/16" open end wrench. Rotate counter clock-wise 1/4 turn to loosen.
7. Pilot arrives from the factory set for NG. Push NG/LP Adjustment Clip inward all the way to set it for LP. See detail view, below. If you see "NAT" printing on the Adjustment Clip, this indicates that the pilot is set to burn NG. Push Clip in so that "NAT" is not visible.
8. Tighten down Hex shaped base of pilot using a 1/2" open end wrench.

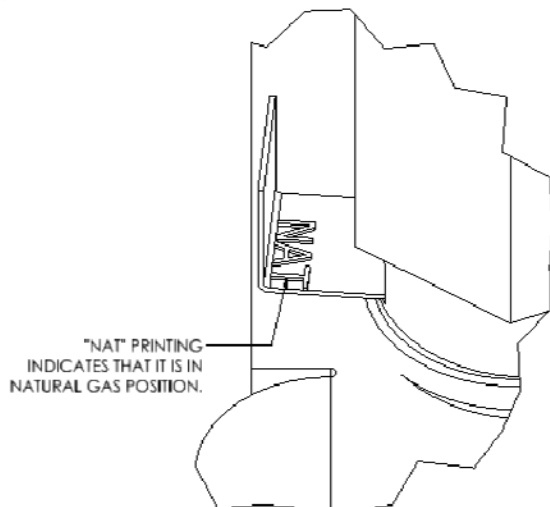
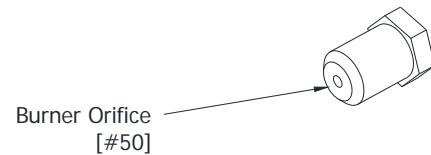
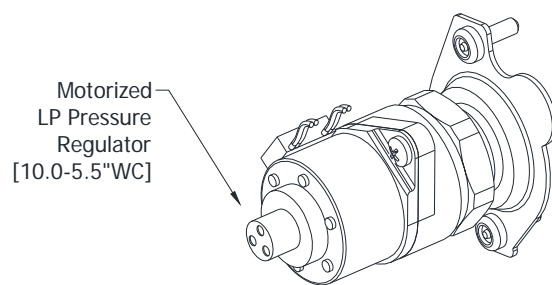
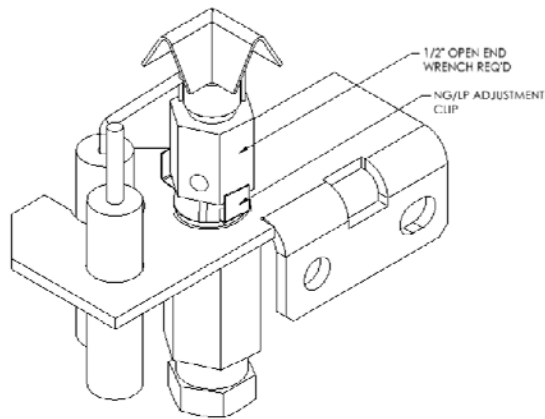

## LPG PRESSURE REGULATOR CONVERSION INSTRUCTIONS

**WARNING:** Failure to position the parts in accordance with these diagrams or failure to use only parts specifically approved with this appliance may result in property damage or personal injury." **AVERTISSEMENT.** Risque de dommages ou de blessures si les pièces ne sont pas installées conformément à ces schémas et ou si des pièces autres que celles spécifiquement approuvées avec cet appareil sont utilisées.

### WARNING!

The installation of this conversion kit must only be undertaken by a qualified and certified gas appliance installer.

### STEPPER MOTOR PRESSURE REGULATOR CONVERSION KIT INSTALLATION OR REPLACEMENT INSTRUCTIONS.

Verify that the following items are present in the package.

- Pressure regulator assembly (E)
- Two (2) screws (F)
- Identification label (G)
- Installation instructions (this document).

- 1 Shut off the gas supply to the valve and shut down the electric supply.
- 2 See Fig. 1. Using a Torx T20, or slotted screwdriver, remove and discard the two (2) pressure regulator mounting screws (A), pressure regulator tower (B), and the spring and diaphragm assembly (C), (if applicable).
- 3 Ensure the rubber gasket (D), which is prefitted as part of assembly (E), is properly positioned, see Fig. 2, otherwise fit the gasket as shown Fig. 2.
- 4 Install the new STEPPER MOTOR pressure regulator assembly, as shown in Fig. 3 and Fig. 4. Use the supplied screws (F), M4 x 0.7 threaded, length of thread  $L=(16\text{ mm} + 0 - 0.5\text{ mm})$ , steel material, resistance class 8.8 (see Fig. 5).
- 5 Manually thread the two conversion kit mounting screws into the valve body. Use a standard screwdriver or T20 Torx bit and tighten to the screws with a fixing torque of  $25\text{lb-in} \pm 5\%$ .  
**IN THE EVENT THAT THE THREADS OF THE VALVE ARE STRIPPED OR DAMAGED, REPLACE THE VALVE.**
- 6 Install the enclosed identification label (G) to the valve body where it can be easily seen.
- 7 Make STEPPER MOTOR and valve electrical connections, apply gas to system and relight appliance according to manufacturers instructions.
- 8 With the main burner "ON", test the new pressure regulator assembly for leaks using a soap solution.
- 9 Relight the main burner and verify proper burner ignition and operation.

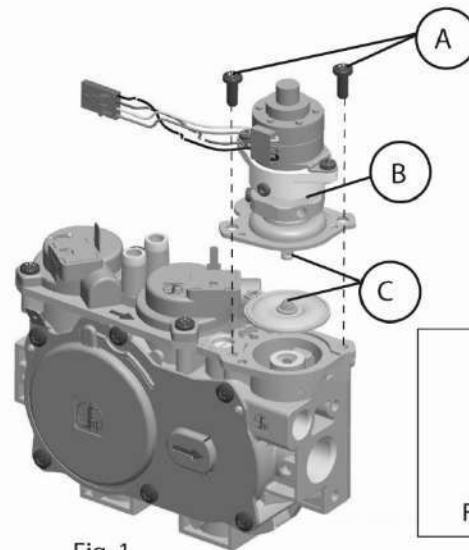

Fig. 1

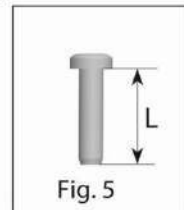

Fig. 5

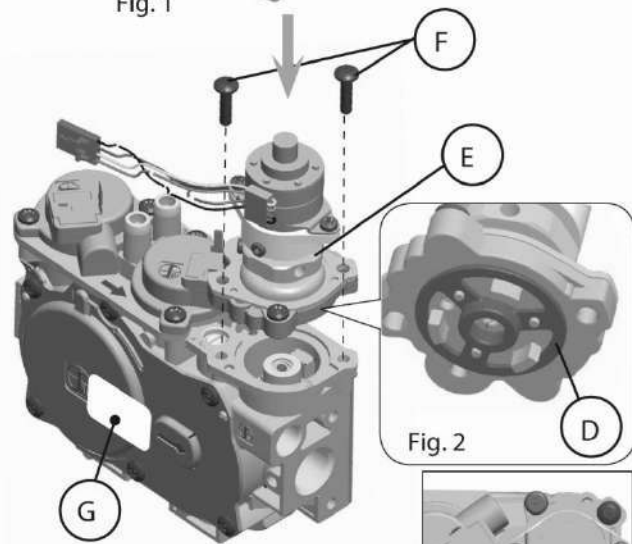

Fig. 3

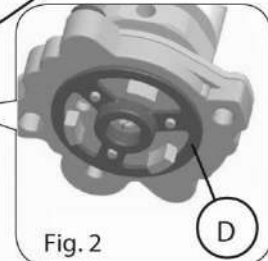

Fig. 2

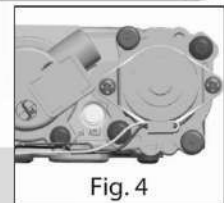

Fig. 4

### WARNING!

Installation should be carried out in a clean environment.

### WARNING!

This modulating conversion kit must ONLY be applied as part of a conversion kit supplied by the **APPLIANCE MANUFACTURER** for the specific appliance, and type of gas, being converted.

### WARNING!

Correct operation of the system cannot be guaranteed if the conversion kit or valve has been dropped or has sustained a strong impact.

**INSTALLER NOTICE.** These instructions must be left with appliance.

## LP GAS PRESSURE REQUIREMENTS

Inlet and manifold gas pressure checking taps are located on gas valve. These ports are only accessible from the outer left side of the fireplace. A qualified installer shall take pressure measurements at these ports to verify and set the correct gas pressures during the LP Kit installation and before fascia materials are installed over the front of this fireplace. Manifold pressure must be taken at the "MANIFOLD PRESSURE" tap and inlet pressure at the "INLET PRESSURE" tap **with the burner operating** by a qualified installer.

	DESIRED INLET PRESSURE	MINIMUM INLET PRESSURE	MAXIMUM INLET PRESSURE	MANIFOLD OUTLET PRESSURE	AIR SHUTTER POSITION
L.P. GAS	<b>12.0" W.C.</b> (2.99 kPa)	12" W.C. (2.99 kPa)	14.0" W.C. (3.49 kPa)	10.0" W.C. (2.5 kPa)	1/4" OPEN MIN. (5 mm)

REGULATE THE FLAME HEIGHT TO "HIGH" POSITION. OUTLET GAS PRESSURES MAY VARY PLUS OR MINUS 5%.

### LPG Proper Input Rates:

With the proper orifices installed and the Outlet Manifold Pressure verified to be per the table, as specified above, this fireplace utilizing LP Gas will have a maximum input rate of 34,250 Btu/Hr.

### Leak Testing Requirements

Prior to completing the conversion process, check for gas leaks with soap and water solution at all plumbing joints prior to placing this appliance into operation. It is recommended that all gas-plumbing joints, factory installed and field installed are checked for leaks.

### Pilot Flame And Main Burner Relationship Verification

Prior to completing the conversion process, the qualified service technician must, light the pilot light and verify the relationship between the pilot light flames and the main burner. The pilot light flames directed towards the propagation ports on the rear and front burner must overlap the propagation ports on the burners. The pilot light flames must be a minimum of 1" long and must overlap the propagation ports on both the rear and front burners as shown in the diagram, below. Verify that the burner tubes ignite quickly and the burner flames propagate smoothly along the entire length of the burners.

### Pilot Flame Length Adjustment

If the pilot light flame length is too short and the system does not maintain a standing pilot, a qualified installer may increase the length of the pilot light flames to meet the two requirements: Minimum pilot light length to maintain a standing pilot light and the pilot light flames must be long enough to overlap burner flame propagation ports.

### Derating At Altitudes Above 2000 Feet

Installation of this appliance at altitudes above 2000 feet requires the gas input rate to be derated. For LPG applications, the main burner orifice size for altitudes above 2000 feet shall be #51. LPG gas input rate for installation above 2000 feet shall be 33,800 Btu/Hr.

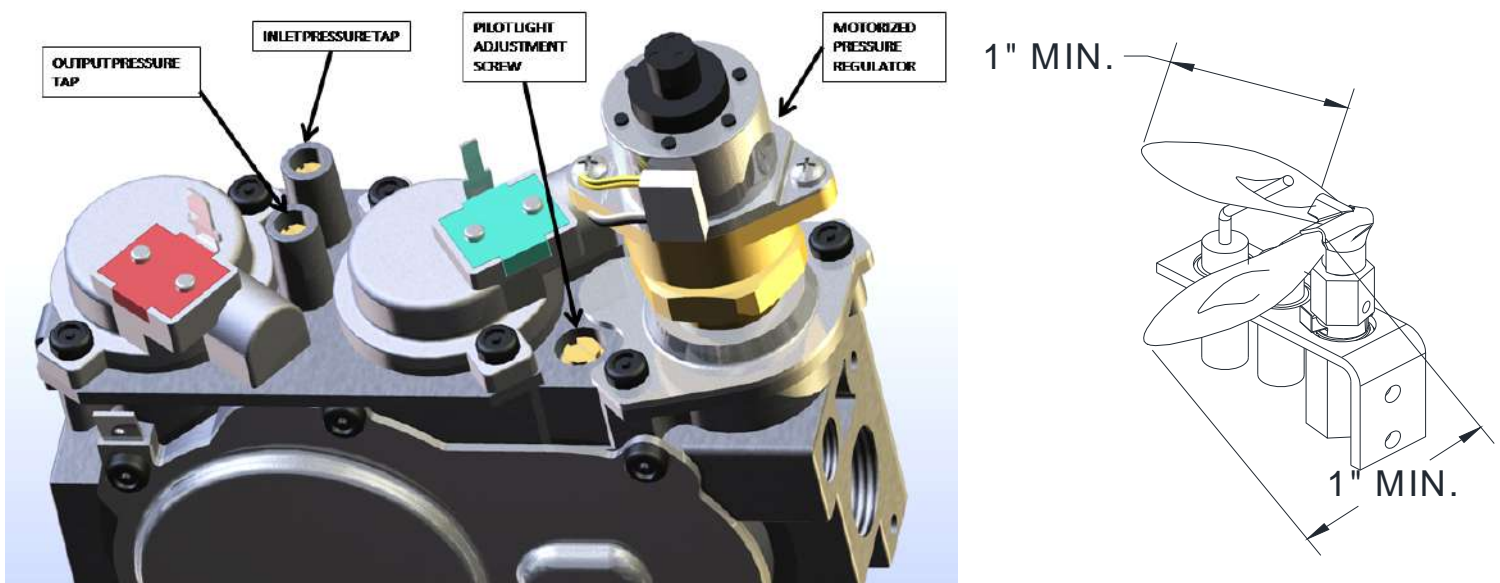

## **CHECKING FOR NORMAL BURNER IGNITION CHARACTERISTICS**

Once the conversion to LPG and all the above steps have been completed, install Burner Media and light the main burner. On the Remote Transmitter, push the On/Off button to ON. Change Thermostat Mode to "MANUAL". The pilot system will begin to spark and then the Main burner should light and flame should not "lift" off burner. If there is any delay in ignition or if flame is "lifting off" burner, turn off burner and carefully check for proper installation of burner media, vent system and proper pilot flame impingement on burner. Burner Media must not block pilot flame. Vent system must be leak proof.

### **WARNING**

**DO NOT PROCEED WITH OPERATION OF THIS FIREPLACE  
UNLESS BURNER "CYCLES" ON/OFF WITHOUT DELAYS!**

### **Attaching LPG Conversion Labels And High Altitude Deration Label**

Two printed informational labels are included with the LPG Conversion Kit. Attach these two labels to the back surface of the Serial Number Plate that is located in the convection air cavity below the firebox. If you are derating this appliance at a high altitude, also attach the High Altitude Deration Label, supplied in the Owner's Manual Packet, to this same surface. Prior to attaching the labels, fill in all the information that is requested in these labels.

For installations from 610-1370 meters (2000-4500 ft.) the orifice size (DMS) for natural and propane gas are \_34\_ and \_51\_, respectively. See data plate for additional information. For high altitude installations consult the local gas distributor or the authority having jurisdiction for proper rating methods. If the installer must convert the unit to adjust for varying altitudes, the information sticker must be filled out by the installer and adhered to the appliance at the time of conversion.

«Cet appareil est équipé pour des altitudes comprises entre 0 et 2000 pieds (0-610 m) seulement»

This appliance has been converted for use at an altitude of \_\_\_\_\_

Orifice size \_\_\_\_\_ Manifold Pressure \_\_\_\_\_

Input (Btu/h) \_\_\_\_\_ Fuel Type \_\_\_\_\_

Date of conversion \_\_\_\_\_ Converted by \_\_\_\_\_

«Cet appreeil a été converti au \_\_\_\_\_

Injecteur \_\_\_\_\_

Pression à la tubulure d'alimentation \_\_\_\_\_

Déoit calorifique \_\_\_\_\_

## ML39 VALVE ASSEMBLY REPLACEMENT PARTS

For replacement parts contact your local Mendota Dealer.

ML39 VALVE ASSEMBLY REPLACEMENT PARTS LIST			
ITEM	QTY	PART NUMBER	DESCRIPTION
1	1	05-04-00062	Pilot Assembly
2	2	65-14-00033	ORIFICE, #33
3	1	HA-96-00016	Proflame Valve Assembly with fittings

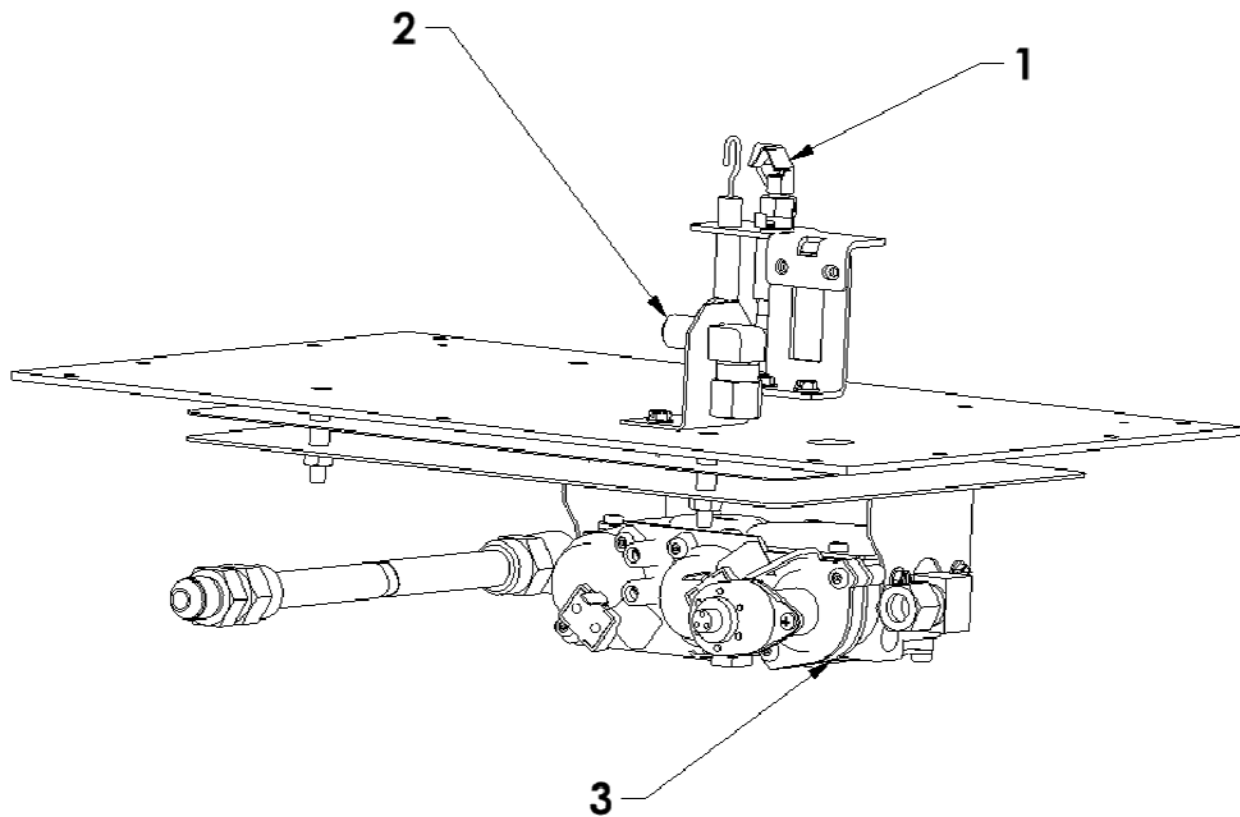

# ML39 GAS IGNITION SYSTEM WIRING DIAGRAM

## ProFlame 2 System Configuration

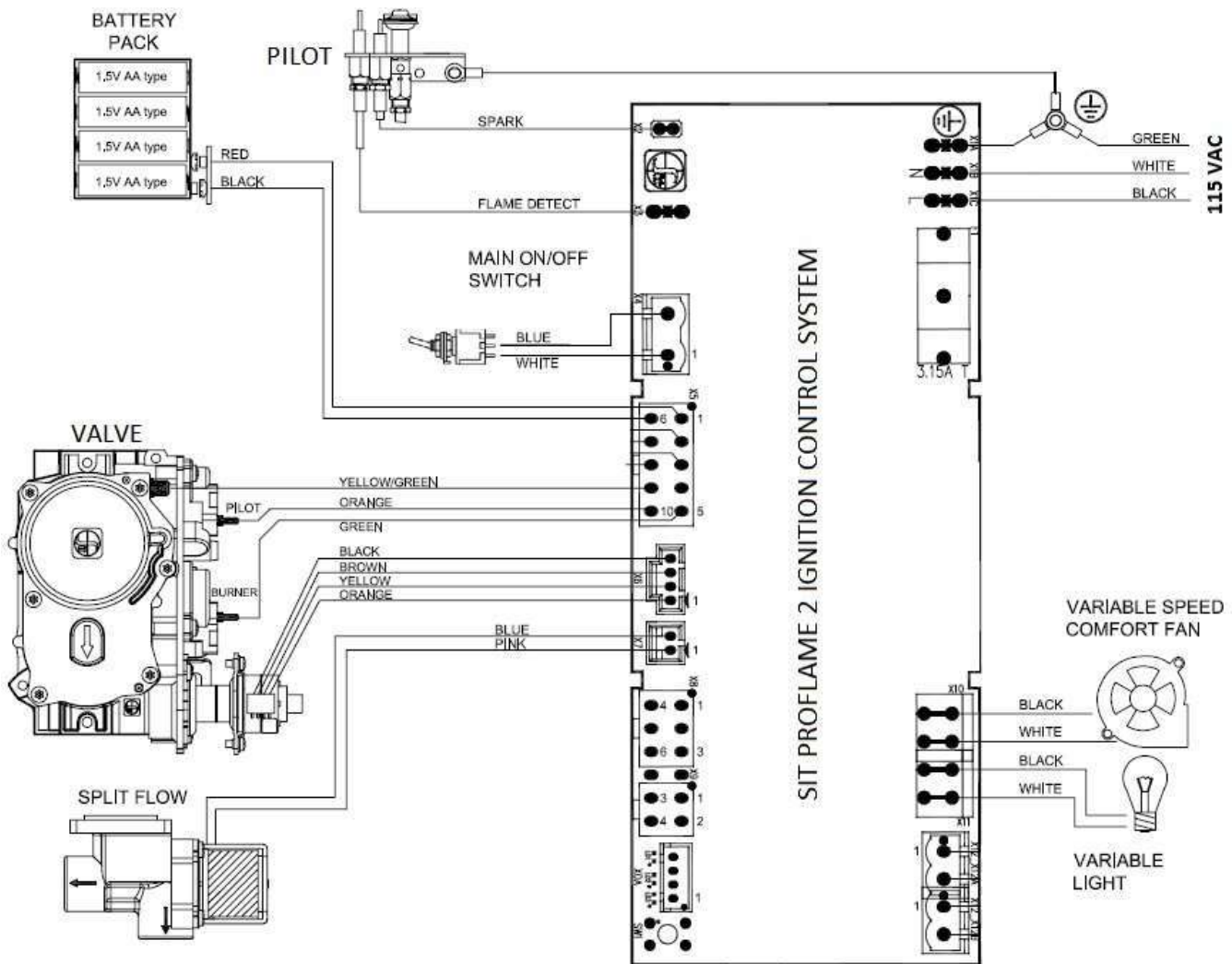

**NOTES:**

-CONNECT WIRES IN JUNCTION BOX ON THE LEFT SIDE OF THE FIREPLACE TO HOUSE POWER USING THE SUPPLIED WIRE NUTS.

-REPLACEMENT WIRE MUST BE OF THE SAME SIZE AND TYPE OF INSULATION AS ORIGINAL.

-THE APPLIANCE MUST BE ELECTRICALLY CONNECTED AND GROUNDED IN ACCORDANCE WITH LOCAL CODES OR, IN THE ABSENCE OF LOCAL CODES, WITH THE CURRENT NFPA 70-NATIONAL ELECTRIC CODE OR CSA C22.1-CANADIAN ELECTRICAL CODE.

-LABEL ALL WIRES PRIOR TO DISCONNECTION WHEN SERVICING CONTROLS. WIRING ERRORS CAN CAUSE IMPROPER AND DANGEROUS OPERATION. VERIFY PROPER OPERATION AFTER SERVICING.

65-01-00457

The appliance must be electrically connected and grounded in accordance with local codes or, in the absence of local codes, with the current NFPA 70-National Electric Code or CSA C22.1-Canadian Electrical Code.

Caution: Label all wires prior to disconnection when servicing controls. Wiring errors can cause improper and dangerous operation” and “Verify proper operation after servicing.”

Attention: Au moment de l’entretien des commandes, étiquetez tous les fils avant le débranchement. Des erreurs de câblage peuvent entraîner un fonctionnement inadéquat et dangereux.” “S’assurer que l’appareil fonctionne adéquatement une fois l’entretien terminé.



# GLASS FRAME ASSEMBLY REPAIR AND REPLACEMENT

**DO NOT** substitute other manufacturer's materials or components.  
**DO NOT** operate unit with cracked, broken or missing glass.  
**DO NOT** abuse the glass door by striking the glass, slamming the door shut, etc

**WARNING**  
 Use only authorized parts and materials obtained from Johnson Gas Appliance Company when replacing defective or damaged glass.

**WARNING**  
 Do not operate this appliance with the glass removed, cracked or broken. Glass should be replaced by a licensed or qualified person.

## To Replace Damaged Glass

Bend Glass Retainer Tabs up 90 degrees. Four tabs hold down the glass and gasket assembly.

Remove the damaged glass and gasket material. Clean the inner surface of the glass frame.

Assemble new gasket on glass edge starting with the bottom left corner. The adhesive on the gasket should make contact with the glass surface. Use tracer lines in gasket to determine where the glass should sit on the gasket surface.

Place glass and gasket assembly in glass frame and carefully bend down glass retainer tabs. Extra glass retainer tabs are provided should any originally used tabs break off.

The glass frame assembly and its individual components are available through Johnson Gas Appliance Company. Contact your dealer for more detailed ordering information.

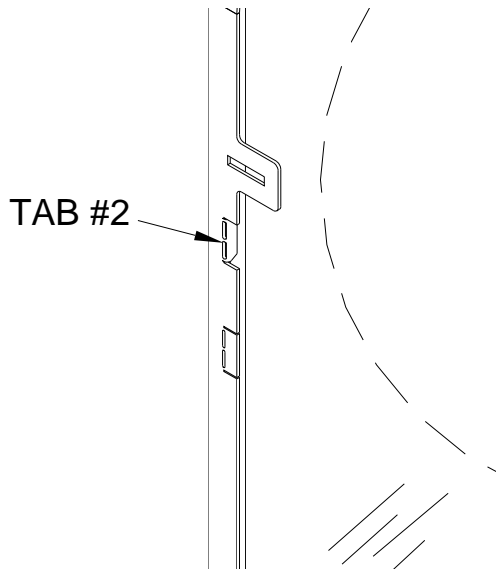

GLASS FRAME ASSEMBLY # HA-96-00012 REPLACEMENT PARTS LIST		
ITEM	PART NUMBER	DESCRIPTION
1	HA-96-00011	FRAME, WELDMNT, GLASS, ML39
2	65-02-00158	GASKET
3	65-06-01367	GLASS, ML39

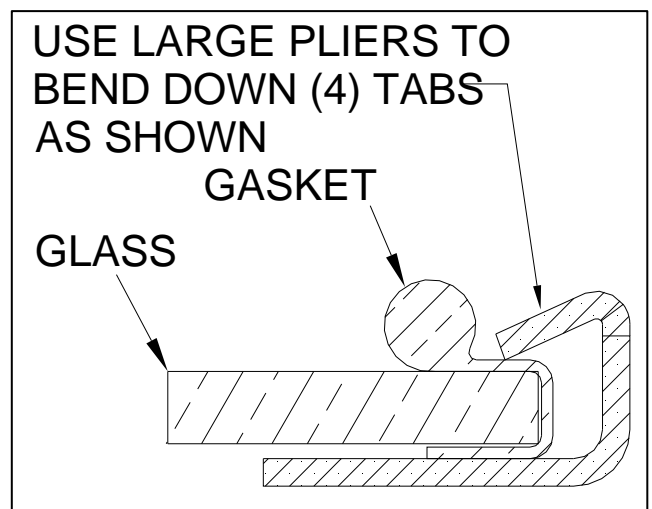
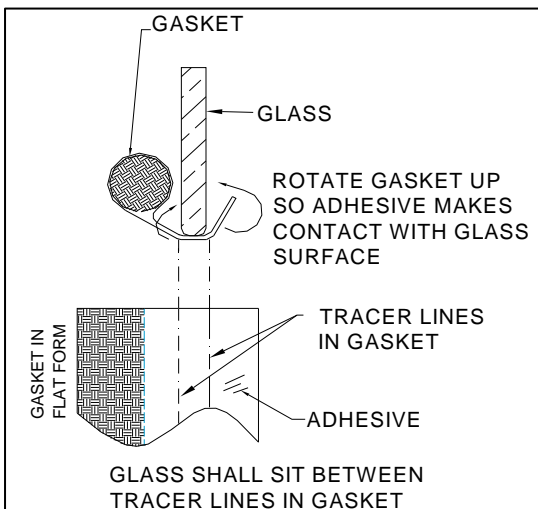

## LISTING LABEL INFORMATION

The model information regarding your specific appliance can be found on the rating plate, which is located in the air gap below the glass frame near the center. When contacting your dealer for any cleaning service or warranty service, always provide the Model Number, Serial Number and Manufactured Date. This information will expedite the warranty verification process.



DIRECT VENT GAS FIREPLACE HEATER  
(POELE AU GAZ HOMOLOGUÉ, À AÉRATION DIRECTE)  
NOT FOR USE WITH SOLID FUEL  
(NE DOIT PAS ÊTRE UTILISÉ AVEC UN COMBUSTIBLE SOLIDE)

MANUFACTURED BY (FABRIQUÉ PAR):  
JOHNSON GAS APPLIANCE CO. CEDAR RAPIDS, IOWA  
CERTIFIED FOR CANADA (HOMOLOGUÉ POUR LE CANADA)  
CONFORMS TO (CONFORME AUX): ANSI Z21.88-2014  
CERTIFIED TO (CERTIFIÉ) CAN/CGA 2.17-M91\* CSA 2.33-2014



**WARNING:** IMPROPER INSTALLATION, ADJUSTMENT, ALTERATION, SERVICE OR MAINTENANCE CAN CAUSE PROPERTY DAMAGE, PERSONAL INJURY, OR LOSS OF LIFE. REFER TO THE OWNER'S INFORMATION MANUAL PROVIDED WITH THIS APPLIANCE. INSTALLATION AND SERVICE MUST BE PERFORMED BY A QUALIFIED INSTALLER. THIS VENTED GAS FIREPLACE HEATER IS NOT FOR USE WITH AIR FILTERS. FOR USE ONLY WITH GLASS BARRIER Part no. AA-11-02117

**MISE EN GARDE:** INSTALLATION, RÉGLAGE, MODIFICATION, ENTRETIEN OU DÉPANNAGE NON APPROPRIÉS POURRONT CAUSER DES BLESSURES OU DES DOMMAGES MATÉRIELS. RÉFÉREZ-VOUS AU MANUEL DU PROPRIÉTAIRE FOURNI AVEC CET APPAREIL. POUR ASSISTANCE OU RENSEIGNEMENTS COMPLÉMENTAIRES, VEUILLEZ CONSULTER UN INSTALLATEUR EXPÉRIMENTÉ, UNE AGENCE DÉ DÉPANNAGE/ENTRETIEN OU COTRE COMPAGNIE GAZIERE, POUR UTILISATION AVEC LES PORTES EN VERRE CERTIFIÉE L'APPAREIL SEULEMENT. NE PAS OPÉRER AVEC LE VERRIÈRE ENLEVER, CRAQUELURE, BRISÉ.

**WARNING:** DO NOT OPERATE THE APPLIANCE WITH GLASS FRONT REMOVED, CRACKED OR BROKEN. REPLACEMENT OF THE PANEL(S) SHOULD BE DONE BY A LICENSED OR QUALIFIED SERVICE PERSON. FOR USE WITH GLASS DOORS CERTIFIED WITH THE APPLIANCE ONLY.

**AVERTISSEMENT:** NE PAS UTILISER L'APPAREIL SI LE PANNEAU FRONTAL EN VERRE N'EST PAS EN PLACE, EST CRAQUÉ OU BRISÉ. CONFIEZ LE REMPLACEMENT DU PANNEAU À UN TECHNICIEN AGRÉÉ. SEULES DES PORTES CERTIFIÉES POUR CET APPAREIL DOIVENT ÊTRE UTILISÉES

	<input type="checkbox"/> NATURAL GAS (GAZ NATUREL)	<input type="checkbox"/> LP GAS (GAS DE PÉTROLE) LIQUÉFIÉ (GPL)
INPUT RATING (BTR/HR) 0-2000ft (0-610m) (ENTRÉE NOMINALE)	34,250	34,250
MIN. INPUT RATING (BTU/HR) 0-2000ft (0-610m) (MINIMALE ENTRÉE NOMINALE)	23,000	28,000
ORIFICE 0-2000ft (0-610m) (ORIFICE)	#33	#50
ORIFICE 2000-5000ft (610-1370m) (ORIFICE)	#34	#51
INPUT RATING (BTU/HR) 2000-5000ft (610-1370m)	32,500	33,800
MAXIMUM OUTPUT (BTU/HR) (SORTIE MAXIMALE)	24,000	24,000
MANIFOLD PRESSURE (in. w.c./kPa) (PRESSION AU COLLECTEUR)	3.5 (0.87)	10.0 (2.5)
MANIFOLD PRESSURE, LOW (in. w.c./kPa) (PRESSION AU COLLECTEUR MINIMALE)	1.6 (0.40)	6.3 (1.57)
MINIMUM INLET PRESSURE (in. w.c./kPa) (PRESSION D'ENTRÉE MINIMALE)	5.0 (1.24)	11.0 (2.74)

THIS APPLIANCE IS ONLY FOR USE WITH THE TYPE OF GAS INDICATED ON THE RATING PLATE AND MAY BE INSTALLED IN AN AFTERMARKET, PERMANENTLY LOCATED, MANUFACTURED HOME (USA ONLY) OR MOBILE HOME, WHERE NOT PROHIBITED BY LOCAL CODES. SEE OWNER'S MANUAL FOR DETAILS. THIS APPLIANCE IS NOT CONVERTIBLE FOR USE WITH OTHER GASES, UNLESS A CERTIFIED KIT IS USED.

CET APPAREIL DOIT ÊTRE UTILISÉ UNIQUEMENT AVEC LE TYPE DE GAZ INDIQUÉ SUR LA PLAQUE SIGNALÉTIQUE. CET APPAREIL PEUT ÊTRE INSTALLÉ DANS UNE MAISON PRÉFABRIQUÉE OU MOBILE (É.-U. SEULEMENT) INSTALLÉE À DEMEURE SI LES RÉGLEMENTS LOCAUX LE PERMETTENT. VOIR LA NOTICE DE L'UTILISATEUR POUR PLUS DE RENSEIGNEMENTS. CET APPAREIL NE PEUT PAS ÊTRE UTILISÉ AVEC D'AUTRES GAZ SAUF SI UNE TROUSSE DE CONVERSION CERTIFIÉE EST FOURNIE.

MINIMUM CLEARANCES TO COMBUSTIBLE CONSTRUCTION			
UNIT TO FLOOR	0in. (0 mm)	GLASS EDGE TO ADJACENT SIDEWALL	16in. (406 mm)
UNIT TO ENCLOSURE SIDEWALL	½ in. (13 mm)	VENT PIPE TOP TO COMBUSTIBLES	2in. (51 mm)
UNIT TO ENCLOSURE BACK WALL	½ in. (13 mm)	VENT PIPE SIDES TO COMBUSTIBLES	1in. (0 mm)
UNIT TOP TO ENCLOSURE CEILING	1-1/2in. (38 mm)	VENT PIPE BOTTOM TO COMBUSTIBLES	1in. (0 mm)
UNIT FLOOR TO ROOM CEILING	60 in. (1524 mm)	8" MANTLE ABOVE DISCHARGE AIR OPENING	12in. (305 mm)

CAUTION: HOT WHILE IN OPERATION. DO NOT TOUCH. KEEP CHILDREN, CLOTHING, FURNITURE, AND FLAMMABLE LIQUIDS OR VAPORS AWAY.

ATTENTION: L'APPAREIL EST CHAUD LORSQU'IL FONCTIONNE. NE PASS TOUCHER L'APPAREIL. SURVEILLER LES ENFANTS. GARDER LES VÊTEMENTS, LES MEUBLES, L'ESSENCE OU AUTRES LIQUIDES À VAPEUR INFLAMMABLES LOIN DE L'APPAREIL.

ELECTRICAL RATING (COURANT NOMINAL): 120 VOLTS 60 HERTZ LESS THAN 1.5 AMPERES

DO NOT REMOVE OR COVER THIS LABEL  
VEILLES A NE JAMES ENLEVER NI DISSIMULER CETTE ÉTIQUETTE

MFG. DATE:

MODEL: ML39

SERIAL NO.

WH-ML39

65-01-000454

THIS PAGE LEFT BLANK,  
INTENTIONALLY.

THIS PAGE LEFT BLANK,  
INTENTIONALLY.

**MENDOTA WARRANTY QUALIFICATION & SERVICE REFERENCE FORM**

As a part of Mendota's on-going program of customer satisfaction, this Form verifies proper installation and operation. It is important as a reference for future service. It insures long life and trouble-free operation of Mendota fireplaces & stoves and qualifies the owner for Mendota's lifetime limited warranty. Owner should sign Form when completed and mail a copy along with Warranty Registration to Mendota.

OPTIONALLY, PLEASE REGISTER AT OUR WEBSITE AT:  
WWW.JOHNSONGAS.COM/MENDOTA-REGISTRATION.ASP

Mendota direct vent fireplaces are sophisticated, hi-tech gas appliances. All installation and operating instructions must be carefully followed. This ML39 fireplace must be installed and serviced by a qualified Mendota approved service person.

**REF: MENDOTA ML39 INSTALLATION MANUAL**

- APPROVED VENT PIPES AND VENT CAP INSTALLED - Per Manual.  
Vent pipes must be fully twist-locked and leak proof.  
Check minimum and maximum vertical / horizontal and vent runs.  
1000° sealant must be used on inner joints at adjustable pipe sections.
- CHECK FOR PROPER CLEARANCES TO COMBUSTIBLES & VENT LOCATIONS - Per Manual
- INSTALL PROPER SIZE GAS LINES - CHECK FOR GAS LEAKS - Per Manual
- CHECK FOR CORRECT GAS PRESSURE AT MANIFOLD - Per Manual
  - a. 3.5 Inches Water Column Maximum - Nat. Gas
  - b. 10.0 Inches Water Column Maximum - L.P. Gas
- CYCLE BURNERS ON/OFF FOR PROMPT IGNITION - Per "LIGHTING INSTRUCTIONS"  
Burner must light IMMEDIATELY - Flame must travel promptly around "curve" & light burner.
- INSTALL LOGS AND ADJUST FLAME - Per Manual  
Proper pilot flame impingement on Flame Sensor & burner - Air shutter opening: 1/8" Nat. Gas -1/2" LP  
Check that flame is "stable" and is not "lifting" off burner

**BRIEF OWNER ON OPERATION AND MAINTENANCE OF UNIT**

- Light Pilot
- Operate Burner
- Train on Remote Control Functions
- Explain Thermostatic Functions

**WARRANTY REGISTRATION**

Your Name: \_\_\_\_\_

Address: \_\_\_\_\_

City: \_\_\_\_\_ State: \_\_\_\_\_ Zip: \_\_\_\_\_

Dealer (Place of Purchase): \_\_\_\_\_

City: \_\_\_\_\_ State: \_\_\_\_\_ Zip: \_\_\_\_\_

Date of Purchase: \_\_\_\_\_ Serial Number: \_\_\_\_\_

Purchaser's Signature: \_\_\_\_\_

MENDOTA ML39 DIRECT VENT FIREPLACE

CUT OUT PAGE AND MAIL TO: JOHNSON GAS APPLIANCE CO., 520 E AVE. N.W., CEDAR RAPIDS, IOWA 52405  
PLEASE REGISTER AT OUR WEBSITE AT: WWW.JOHNSONGAS.COM/MENDOTA-REGISTRATION.ASP

TAPE SHUT

POSTAGE  
NEEDED

JOHNSON GAS APPLIANCE COMPANY  
520 E AVENUE N.W.  
CEDAR RAPIDS, IA 52405

# **MENDOTA EXTENDED PROTECTION AND LIMITED WARRANTY**

## **MENDOTA ML39 DIRECT VENT FIREPLACE**

Mendota Division of Johnson Gas Appliance Company, 520 E Avenue N.W. Cedar Rapids, Iowa 52405, extends this Extended Protection and Limited Warranty to the original purchaser of a Mendota FV46 Fireplace, which is limited and used under normal home conditions.

### **STANDARD WARRANTY:**

JOHNSON GAS APPLIANCE CO., MENDOTA DIVISION, WARRANTS THAT YOUR NEW MENDOTA FIREPLACE AND ALL ITS COMPONENTS ARE FREE FROM MANUFACTURING AND MATERIAL DEFECTS FOR A PERIOD OF ONE YEAR FROM THE DATE OF INSTALLATION. SUBJECT TO PROOF OF PURCHASE AND THE CONDITIONS AND LIMITATIONS OUTLINED, BELOW.

### **EXTENDED WARRANTY:**

THE MAIN BURNER ASSEMBLIES ARE WARRANTED FOR A PERIOD OF 2-YEARS TO THE ORIGINAL OWNER, FROM THE DATE OF PURCHASE. SUBJECT TO PROOF OF PURCHASE AND THE CONDITIONS AND LIMITATIONS OUTLINED, BELOW.

THE HEAT EXCHANGER, COMBUSTION CHAMBER AND OUTER SHIELD OF THE MENDOTA FV46 FIREPLACE ARE WARRANTED FOR 10-YEARS TO THE ORIGINAL OWNER. SUBJECT TO PROOF OF PURCHASE AND THE CONDITIONS AND LIMITATIONS OUTLINED, BELOW.

This new Mendota Fireplace must be installed & serviced by a competent, authorized service contractor. It must be installed and operated at all times in accordance with the installation and operating instructions furnished with the Fireplace. All adjustments to logs, coals or burner must be made by an authorized Mendota person. Any alteration, willful abuse, accident or misuse of the product shall nullify this warranty. This warranty does not cover glass or log breakage.

This limited warranty does not cover the cost of service calls, the cost of labor to remove or install parts covered by this limited warranty, freight or other transportation expenses, which may be incurred in connection with obtaining performances under this limited warranty. The remedy for damages as the result of any defects in this product which have been warranted herein is limited to replacement parts and does not include any incidental, indirect or consequential damages or expenses sustained in connection with the product, including damages to property, except as provided by law.

2) This warranty is non-transferable and is made to the original retail purchaser, provided the purchase was made through an authorized Mendota dealer.

Mendota is not responsible for any damage to or malfunction of the Fireplace unless caused by a defect in material or workmanship from normal home use. Damage caused by abuse, improper installation, improper servicing, and installation by unqualified personnel or breach of conditions of this limited warranty will excuse Mendota from performance of any part of this limited warranty. Mendota has the right to investigate and inspect the exact, original Fireplace and entire installation (without any alterations or tampering) in the event a claim is made to determine whether the claimed damage or malfunction was caused by abuse, improper installation or other cause outside this warranty. Mendota is not responsible for any repairs or material purchases that have not received prior written approval from Mendota.

NOTE: Minor warping of certain parts or discoloration is normal and is not a defect covered by this warranty. Major warping of parts can be caused by over-firing of your Mendota Fireplace. Over-firing above rated nameplate specification is as contrary to the manufacturer's instructions and may void this warranty.

This warranty may not be extended by our representatives or any third party in any manner. The company neither assumes, nor authorizes any third party to assume, on its behalf, any other liabilities with respect to the sale of this Mendota product.

3) Mendota may at its discretion, fully discharge all obligations of this warranty by refunding the wholesale price of the defective part(s).

4) All other warranties - expressed or implied - with respect to the product, its components and accessories, or any obligation/liabilities on the part of the company are hereby expressly excluded. Products made by other manufacturers, sold with the Fireplace or thereafter, are not covered by this limited warranty. The use of unauthorized components will make this warranty null and void.

5) It remains the full responsibility of the owner to operate this appliance within the guidelines provided in the Installation Manual and the Operating Instructions Manual accompanying this appliance. Further, the owner shall bear full responsibility to enforce clearances to combustibles requirements and cautioning others about hot glass surfaces and hot metal surfaces. Owner, by operating this appliance, accepts that this is a heat producing appliance which has glass and steel parts that are hot enough to cause severe burns. Owner accepts that this appliance requires close monitoring of children and vulnerable individuals who are in the vicinity of this appliance when this appliance is in operation. Mendota does not assume or accept any liability claims for burns or other physical or material damages resulting from touching hot glass surfaces and hot metal surfaces that are part of this appliance or other adjacent object such as hearth pads and mantels that may heat up during operation of this appliance.

This warranty shall be effective only if the original purchaser of the Mendota appliance is registered with Mendota Division within thirty (30) days of the date of purchase. Such registration or the failure to register shall not be deemed to create any obligation or liability by the manufacturer and this warranty with its conditions and limitations shall be the only procedure for obtaining any rights against the manufacturer and expresses the sole obligation and responsibilities of the manufacturer which are offered to the original purchaser and accepted upon purchase of the appliance.

Mendota Division, reserves the right to make changes at any time without notice, in design, material, specifications, prices and the right to discontinue styles and products.

Some states do not allow the exclusion of limitation of incidental or consequential damages or limitations on how long an implied warranty lasts, so the above limitation or exclusion may not apply to you. This warranty gives you specific legal rights and you may also have other rights which vary from state to state.

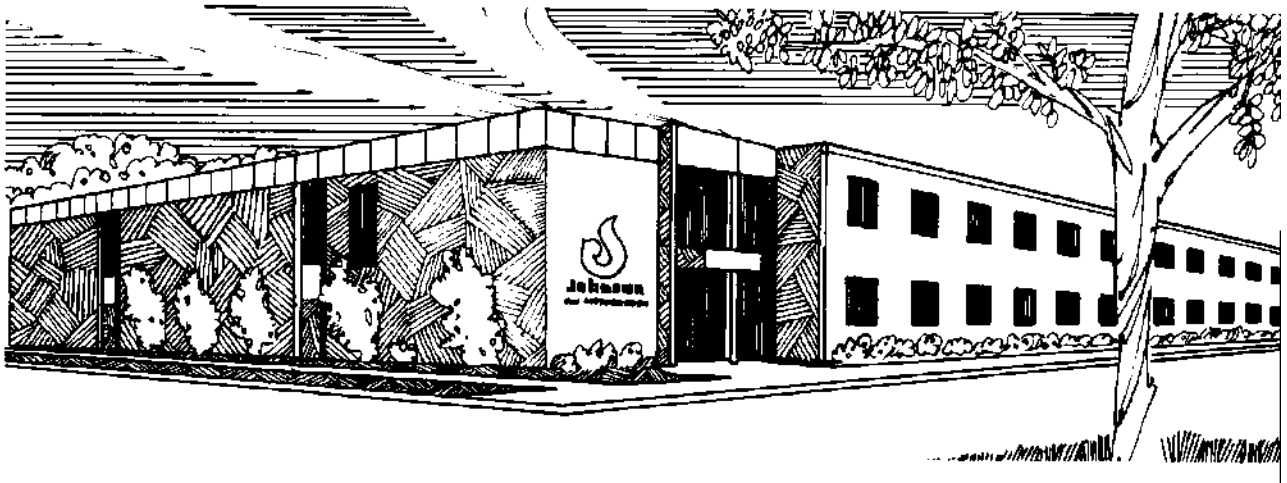

Johnson Gas Appliance Company  
520 E Avenue N.W. - Cedar Rapids, IA 52405  
Mendota Hearth Division

WEBPAGE: [www.johnsongas.com](http://www.johnsongas.com) or [www.mendotahearth.com](http://www.mendotahearth.com)