

MENDOTA

GAS DIRECT VENT FIREPLACE

WITH
HEARTHGLO SEALED COMBUSTION SYSTEM
Model DXV-35 TIMBER FIRE with Direct Rear Vent Option
STANDARD FRONT BAY FRONT

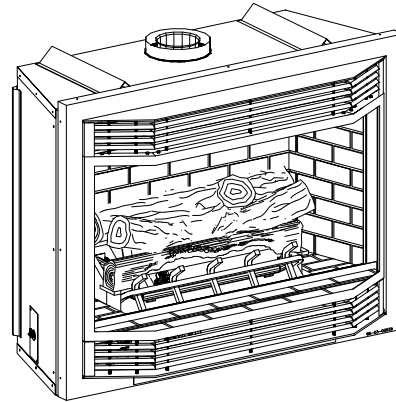
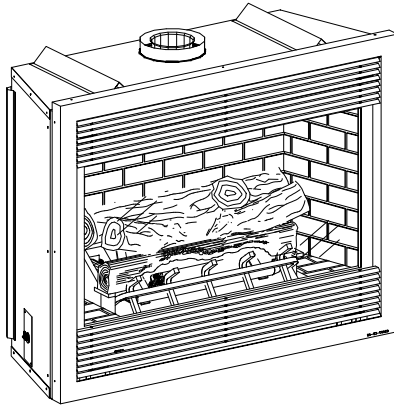

INSTALLATION & OPERATING INSTRUCTIONS



We recommend that our gas hearth products be installed and serviced by professionals who are certified in the U.S. by the National Fireplace Institute® (NFI) as NFI Gas Specialists.

NO. TF-0616



WARNING: Improper installation, adjustment, alteration, service or maintenance can cause injury or property damage. Refer to this manual. For assistance or additional information consult a qualified installer, service agency or the gas supplier.

FOR YOUR SAFETY:

IF YOU SMELL GAS:

1. OPEN WINDOWS.
2. DO NOT TOUCH ELECTRICAL SWITCHES.
3. DO NOT TRY TO LIGHT ANY APPLIANCE.
4. EXTINGUISH ANY OPEN FLAME
5. DO NOT USE THE PHONE IN YOUR BUILDING.
6. IMMEDIATELY CALL YOUR GAS SUPPLIER FROM A NEIGHBOR'S PHONE.
7. FOLLOW THE GAS SUPPLIER'S INSTRUCTIONS.
8. IF YOU CANNOT REACH YOUR GAS SUPPLIER, CALL THE FIRE DEPARTMENT.

FOR YOUR SAFETY

INSTALLATION AND SERVICE MUST BE PERFORMED BY A QUALIFIED INSTALLER, SERVICE AGENCY, OR THE GAS SUPPLIER. DO NOT STORE OR USE GASOLINE OR OTHER FLAMMABLE VAPORS AND LIQUIDS IN THE VICINITY OF THIS OR ANY OTHER APPLIANCE

WARNING: DO NOT OPERATE THIS APPLIANCE WITH THE GLASS REMOVED, CRACKED OR BROKEN. REPLACEMENT OF GLASS SHOULD BE DONE BY A LICENSED OR QUALIFIED PERSON.

WARNING: MENDOTA GAS FIREPLACES ARE HEAT PRODUCING APPLIANCES. DO NOT BURN WOOD, PAPER OR OTHER MATERIALS IN THE FIREPLACE. THE FIREPLACE IS DESIGNED AS A SUPPLEMENTAL HEAT SOURCE. IT IS ADVISABLE TO HAVE AN ALTERNATE HEAT SUPPLY.

WARNING: IF THE INFORMATION IN THIS MANUAL IS NOT FOLLOWED EXACTLY, A FIRE OR EXPLOSION MAY RESULT CAUSING PROPERTY DAMAGE, PERSONAL INJURY OR LOSS OF LIFE.

IMPORTANT: THESE INSTRUCTIONS ARE TO REMAIN WITH THE HOMEOWNER!

TABLE OF CONTENTS

<i>LOCATING THE FIREPLACE AND GENERAL INFORMATION</i>	4
<i>TOP VENT OPTIONS DISCUSSION</i>	5
<i>GAS SUPPLY REQUIREMENTS</i>	6
<i>GAS PRESSURE REQUIREMENTS</i>	7
<i>EXTERIOR VENTLOCATIONS AND RESTRICTIONS</i>	8
<i>GENERAL FLUE VENTING INSTRUCTIONS</i>	9
<i>GENERAL INSTALLATION INSTRUCTIONS</i>	10
<i>INSTRUCTIONS FOR VENTING</i>	11
<i>SPECIFICATIONS & CLEARANCES</i>	12
<i>FLUE VENTING INSTRUCTIONS</i>	13
<i>TOP FLUE VENTING COMPONENTS</i>	13
<i>FLUE VENTING REQUIREMENTS</i>	14
<i>L.P. GAS MINIMUM HEIGHT HORIZONTAL TERMINATION</i>	15
<i>MINIUM RISE THROUGH THE WALL VENTING</i>	16
<i>TOP VENT COMPONENTS LIST</i>	17
<i>ELEVATED THROUGH THE WALL VENTING</i>	18
<i>VERTICAL THROUGH THE ROOF VENTING</i>	19
<i>RANDOM LOG INSTALLATION</i>	22
<i>TIMBERFIRE LOG SET INSTALLATION</i>	22
<i>INSTALLATION & LIGHTING CHECK OFF LISTS</i>	27
<i>INSTALLATION CHECK OFF LIST</i>	27
<i>LIGHTING CHECK OFF LIST</i>	27
<i>LIGHTING INSTRUCTIONS</i>	28
<i>THERMOSTAT OR REMOTE CONTROL OPERATION</i>	29
<i>BLOWER & BURNER REMOVAL& INSTALLATION-BLOWER WIRING</i>	30
<i>MENDOTA BLOWER & BURNER REMOVAL & INSTALLATION</i>	30
<i>TROUBLE SHOOTING - MAIN BURNER GAS FLAME ADJUSTMENT</i>	31
<i>CUSTOMER INFORMATION AND TROUBLE-SHOOTING</i>	32
<i>MAINTENANCE</i>	33
<i>NATURAL TO LP GAS CONVERSION</i>	35
<i>REPLACEMENT PARTS</i>	36
<i>GRILL INSTALLATION</i>	37
<i>MENDOTA DESIGNER FRONTS INSTALLATION INFORMATION</i>	37
<i>LABEL REPRESENTATION</i>	39
<i>MENDOTA EXTENDED LIFETIME PROTECTION AND LIMITED WARRANTY</i>	42

SPECIFICATIONS
MODEL DXV-35 TIMBER FIRE

High Fire - Adjustable to - Low Fire

BTUH. (MODEL DXV-35)	NAT. GAS	33,000	21,000
BTUH. (MODEL DXV-35)	LP GAS	33,000	18,500

MAIN ORIFICE.....#32 NAT. GAS -- #50 L.P. GAS

OVERALL EFFICIENCYEXCEEDS D.O.E. EFFICIENCY REQUIREMENTS (A.F.U.E.) FOR DIRECT VENT
..... WALL HEATERS

CO-AXIAL DIRECT VENT FLUE TOP VENT: 4" INNER, 6 5/8" OUTER; REAR: 5" INNER 8" OUTER

TOTAL WEIGHT 185 POUNDS

SAFETY AGA CERTIFIED PILOT GENERATOR, MILLIVOLT SYSTEM
ACTIVATED WITH SWITCH, THERMOSTAT OR REMOTE CONTROL.

GAS REQUIREMENTS..... SUPPLY PRESSURE: GAS INLET: 3/8" N.P.T.
NAT. GAS: 7" W.C. (5" W.C. MIN., 11" W.C. MAX.)
L.P. GAS: 11.0" W.C. (11" W.C. MIN., 13" W.C. MAX.)

ELECTRICAL REQUIREMENTS 115 VOLT, LESS THAN 2 amps

APPROVED VENT SYSTEMS: AMERIVENT, DURAVENT, SELKIRK METALBESTOS, SECURITY CHIMNEY

MINIMUM CLEARANCES FROM COMBUSTIBLE CONSTRUCTION

Unit to floor	0 in.	Unit to enclosure sidewalls	0.5 in.
Unit to enclosure sidewall	0.5 in.	Unit top to ceiling	18 in.
Vent to enclosed	1 in.	Wall Pass-Through to framing	1 in.
Vent to adjacent sidewall	10 in.	Mantle above discharge air opening	14 in.

Certified under ANSI Z21.88 (2002) CSA 2-33 (2002) "Vented Gas Fireplace Heaters" not for use with solid fuel. Approved for bedroom installations and mobile homes. UL307B approved for "mobile homes, after first sale of home, not for recreational vehicles."

Gas appliances must be tested and certified by a nationally recognized testing and certification agency to American National Standards Institute - ANSI Gas Appliance Safety Standards
The Mendota Gas DXV Fireplace has been tested and certified by Intertek Testing Services 8431 Murphy Drive, Middleton, WI

FIREPLACE INCLUDES A HEARTHGLO SEALED COMBUSTION SYSTEM, 6-PIECE CERAMIC FIBER LOG SET & COALS, FIREBRICK LINED FIREBOX, NEO-CERAM GLASS, PIEZO IGNITER, DUAL BLOWERS, AGA CERTIFIED SAFETY SYSTEM, and WALL THERMOSTAT.

OPTIONS: DIRECT REAR VENT KITS, BLACK, BRASS, CLASSIC BRASS OR CLASSIC SILVER TONE GRILL SETS, BLACK OR 24K GOLD "VICTORIA" & "TUSCANY" FILIGREE FRONTS, ANDOVER ARCHED DOORS & 4 COLOR OVERLAY FRONTS, PRAIRIE RECTANGULAR DOORS & 4 COLOR OVERLAY FRONTS, WELLINGTON FRONT, VERSIHEAT REMOTE FORCED AIR HEAT- TRANSFER SYSTEM, LP CONVERSION KIT.

Building Permit and Installation Inspection Approval Requirements



We recommend that our gas hearth products be installed and serviced by professionals who are certified in the U.S. by the National Fireplace Institute® (NFI) as NFI Gas Specialists.

www.nficertified.org

All installations of Mendota Fireplaces and Inserts must comply with all the requirements stated in this Installation and Operating Instructions Manual. The Dealer and/or installer must also obtain all required Building Permits and Inspection Approval from the local building inspection department or the local body having jurisdiction. In order to validate warranty coverage, Mendota may require facsimile copies of the Building Permit and Inspection Approval forms. Failure to provide adequate proof that the installation conforms to all local requirements and the requirements stated in the Installation and Operating Instructions Manual will void all applicable warranty.

INSTALLER: THESE INSTRUCTIONS ARE TO REMAIN WITH HOMEOWNER.

CONGRATULATIONS!

You are the owner of a world-class heat producing gas direct vent sealed combustion fireplace.

This elegant, highly efficient Fireplace will be a constant source of comfort and fascination. It will be the focal point of beauty and interest in your home.

The Mendota Gas Fireplace is a true heating appliance incorporating the traditional aesthetics of fireplace fire viewing with the controllability and fuel efficiency of a home gas furnace. Of particular interest is the low fuel consumption and brilliant fire viewing afforded by the realistic HearthGlo wood fire-like combustion system.

Carefully read the following instructions prior to actual installation. Proper Mendota Gas Fireplace installation and operation will give you years of safe, trouble free comfort and enjoyment.

If you have any questions regarding installation or operation of your Mendota Fireplace please contact your local dealer.

...CAUTION...

FOR YOUR SAFETY do not install or operate your Mendota Gas Fireplace without first reading and understanding this manual. Any installation or operational deviation from this manual voids the Mendota Gas Fireplace Warranty and may prove hazardous!

Due to high temperatures, the Fireplace should be located out of traffic and away from furniture and draperies. Children and adults should be alerted to the hazards of high surface temperature and should stay away to avoid burns or clothing ignition. Young children should be carefully supervised when they are in the same room as the Mendota Gas Fireplace.

Clothing or other flammable material should not be placed on or near the Fireplace.

The Mendota Gas Fireplace is a powerful, efficient heating unit. It has been designed as a major source of supplemental heat. As with any mechanical appliance there can be component shut downs. It is advisable to have an alternate heat supply.

Installation, repair and any adjustments to logs or burner must be done by a qualified service person. The Fireplace should be inspected before use and at least annually by a professional service person. More frequent cleaning may be required due to excessive lint from carpeting, bedding material, carbon build-up, etc. It is imperative that control compartments, burners and circulating air passageways of the appliance be kept clean. The burner and pilot flames and logs should be visually checked periodically.

DO NOT use this Fireplace if any part has been under water or exposed to moisture corrosion. Immediately call a qualified service technician to inspect the Fireplace and replace any part of the control system and any gas control, which has been under water. DO NOT use this fireplace if the burner does not light immediately. Turn unit off and call Mendota approved service person if there is any delay in burner light-off.

It is Johnson Gas Appliance Company's policy that no responsibility is assumed by the Company or by any of its employees or representatives for any damages caused by an inoperable, inadequate, or unsafe condition which is the result, either directly or indirectly, of any improper operation, installation or servicing procedures.

Building Permit and Installation Inspection Approval Requirements

All installations of Mendota Fireplaces and Inserts must comply with all the requirements stated in this Installation and Operating Instructions Manual. The Dealer and/or installer must also obtain all required Building Permits and Inspection Approval from the local building inspection department or the local body having jurisdiction. In order to validate warranty coverage, Mendota may require facsimile copies of the Building Permit and Inspection Approval forms. Failure to provide adequate proof that the installation conforms to all local requirements and the requirements stated in the Installation and Operating Instructions Manual will void all applicable warranty.

INSTALLER: THESE INSTRUCTIONS ARE TO REMAIN WITH HOMEOWNER.
--

GENERAL INFORMATION

Your Mendota Gas Fireplace has a state-of-the-art co-axial direct vent, sealed combustion system. This advanced, highly efficient system brings in outside air for combustion has a separate exhaust vent and efficiently heats and re-circulates room air. The Mendota system maintains high air quality, maximizes efficiency and assures proper operation in today's "tight" homes.

SAFETY AND STRUCTURAL CONCERNS:

The DXV Fireplace must be installed and serviced by a Mendota approved service person. Any adjustments to burner, pilot, logs or coal bed must be made by a Mendota approved service person. Pilot flame must be checked with voltmeter. Pilot flame must register a minimum of 325 on Millivolt meter. If pilot goes out always wait five (5) minutes before relighting pilot. **ALWAYS**

VENTING REQUIREMENTS: See Page 5 for specific information on venting options.

This Mendota Fireplace can be vented using AMERIVENT, DURAVENT, SELKIRK METALBESTOS, SECURITY CHIMNEY brands of coaxial pipe off the top or using 5"x8" coaxial pipe off the rear.. For instructions and specifications for venting off the rear, see the Instructions included with this Manual. Use only Mendota specified vents and vent caps when installing your fireplace. Closely follow venting locations, directions and requirements. Observe the restrictions relating to vent position on exterior of home (see pg. 8). Be sure all vent pipe sections are fully twist-locked and leak-proof. Be sure 1000° Silicate Stove Sealant is used on the inner pipe joints of all Simpson DuraVent pipe components and all adjustable pipe sections manufactured by Simpson DuraVent and American Metals.

REMOVE THE GLASS WHEN LIGHTING THE PILOT. The burner must light immediately & the flame must travel promptly and smoothly around "curve" and light entire burner. The flame must not "lift" off burner. DO NOT operate unit if burner does not light immediately or if flame lifts off burner.

The Mendota Direct Vent Fireplace may be placed within inches of adjacent sidewalls. (See Figure 4: Specifications & Clearances on pg. 12 and pg. 22). The fireplace may be placed directly on concrete or wood flooring. If the appliance is to be installed on carpeting, vinyl or other combustible material other than wood flooring, the appliance shall be installed on a metal or wood panel extending the full width and depth of the appliance. Combustible mantels must be installed at a minimum of 14" above top of the heat outlet grill and no more than 8" out from wall (see Figure 4: Specifications & Clearances, pg. 12 and pg. 22). Non-combustible (marble, brick, stone, etc.) mantels or mantels with steel protector plate on underside can be installed at any desired height above upper grill.

Never block off upper or lower grills. Always use Mendota grills and Mendota approved vent systems and vent caps.

A non-combustible hearth protector is required and must extend a minimum of 12" in front of the fireplace. If fireplace is raised off floor 6" or more, no hearth protector is required.

HEATING PERFORMANCE:

Mendota Gas Built-in Fireplaces are true, high efficiency gas heaters. With its high heat output the Mendota Fireplace will heat a large area of your home if situated to maximize heat circulation. Air movement options for maximizing heat circulation, which can be considered, are through-the-wall grills or floor grills, the continuous operation of central heating furnace blowers, or ceiling fan. **The most efficient method for overall heat distribution is a ceiling fan.** The heat output of the Fireplace can be reduced by up to 11,000 BTUH by slowly turning the Hi/Lo temperature knob on the gas valve counter clockwise from "Hi" to "Lo". Blower can also be turned down to reduce heat output.

AESTHETIC CONSIDERATIONS:

Burning or static fireplaces are a major aesthetic focus in any room. Locate your gas fireplace as you would a television set. The Mendota Hearth Gas Fireplace will be a continuing source of comfort and fascination. Corner installations will afford you the greatest potential for viewing in many rooms.

We suggest installing the Mendota Fireplace 6 to 12 inches above the floor by utilizing an elevated hearth.

ELECTRICAL REQUIREMENTS:

A blower is standard on your Mendota Direct Vent Fireplace. A 115 volt electrical service must be supplied at the fireplace location at the time of installation. It must be electrically grounded in accordance with local codes or in their absence with current edition of the National Electric Code ANSI/NFPA 70. Power supply to blower must be continuous. DO NOT use switch or variable control in power supplied to fireplace.

The blower on this appliance is equipped with a three-prong plug for protection against shock hazard and should be plugged directly into the grounded three-prong receptacle provided with the fireplace. Do not cut or remove the grounding prong from the plug.

NOTE: The blower output can be adjusted with the rheostat. There will be delays in blower operation during "heat-up" (approx. ½hr.) and extended blower operation during "cool-down" (approx. ½ hr.) of unit (see Blower Wiring Diagram pg. 42).

Thermostat wire should be run from desired thermostat location (or "on/off") switch to the gas control (located behind lower grill) – see thermostat installation section (pg. 29).

TOP VENT OPTIONS DISCUSSION

This Mendota Fireplace can be vented using AMERIVENT, DURAVENT, SELKIRK METALBESTOS, SECURITY CHIMNEY brands of coaxial pipe. Use only Mendota specified vents and vent caps when installing your fireplace. Closely follow venting locations, directions and requirements provided in this Manual. Observe the restrictions related to vent position on exterior of home ([see pg. 8](#)).

Make certain that all vent pipe sections are fully twist-locked and leak-proof. Note: When using Dura-vent pipe you must use a silicate stove masonry sealant [Milpak Sealant #65-06-00909] on all inner pipe joints. On the exterior (air intake) pipe joints, high temperature foil tape may be used instead of the masonry sealant. Contact your dealer to obtain this sealant material.

TOP VENTING

The DXV-35 Fireplace comes from the factory configured for venting off the top using 4" x 6-5/8" Coaxial Vent Pipes. AMERIVENT, DURAVENT, SELKIRK METALBESTOS, SECURITY CHIMNEY brand pipes and venting components may be used when venting off the top.

Venting off the top on the DXV-35 Fireplace provides a large degree of flexibility for many venting configurations. However, a few critical limitations must be understood and adhered to prior to planning to vent off the top.

Limitation: A 12" vertical pipe section must be connected to the top starter collar of the DXV-35. With the 12" vertical section connected, you may only install one 90-degree elbow and a maximum 6" horizontal pipe section before connecting the horizontal vent cap.

Limitation: The maximum horizontal run allowed when venting off the top is 12 feet in conjunction with a minimum 4 feet vertical run. This 12 feet horizontal run can only be used if a straight vertical run of 48 inches (4 feet) is connected directly to the top of the DXV35. DO NOT EXCEED THE MAXIMUM 12 FEET HORIZONTAL RUN. EVEN IF THE VERTICAL SECTION YOU INSTALLED IS GREATER THAN 4 FEET, DO NOT EXCEED THE 12 FEET MAXIMUM HORIZONTAL RUN THROUGHOUT THE ENTIRE VENT SYSTEM.

GAS SUPPLY REQUIREMENTS

CORRECT GAS PRESSURE AND PROPER GAS SUPPLY LINE SIZING IS IMPERATIVE TO THE SUCCESSFUL PERFORMANCE OF YOUR MENDOTA GAS FIREPLACE. BE SURE THE GAS SUPPLIER OR PLUMBER CAREFULLY CHECKS FOR CORRECT GAS PRESSURE AND GAS LINE SIZING WHEN INSTALLING THE FIREPLACE.

IT IS CRITICAL TO CAREFULLY CHECK FOR GAS LEAKS WHEN HOOKING UP THE FIREPLACE -- CHECK WITH SOAP & WATER SOLUTION.

BE SURE TO INSTALL "APPROVED" FLEX GAS LINE WITH BRASS-TO-BRASS FITTINGS TO PREVENT GAS LEAKS AT CONNECTIONS.

GAS SUPPLY PIPING MUST INCLUDE A DRIP LEG TO ELIMINATE THE POSSIBILITY OF CONTAMINANTS ENTERING THE GAS TRAIN. ADHERE STRICTLY TO LOCAL AND NATIONAL CODES FOR ENTIRE INSTALLATION.

GAS SUPPLY LINE SIZING

The Mendota Gas Fireplace comes equipped with a 3/8" N.P.T. (1.0cm) inlet on the main gas valve. This may be removed if a 1/2" flexible connector is used. Gas supply piping can enter the Fireplace cabinet from either the left or right side.

Install an approved individual shut-off valve in supply line to the fireplace. The appliance and its individual shut-off valve must be disconnected from the gas supply piping system during any pressure testing of that system at test pressures in excess of 1/2 PSIG (3.5 kPa).

The appliance must be isolated from the gas supply piping system by closing its individual manual shut-off valve during any pressure testing of the gas supply piping system at test pressures equal to or less than 1/2 PSIG (3.5 kPa).

The proper gas line diameter must be selected to run from the supply regulator to the Fireplace. Refer to the following table for proper gas pipe diameters. Strictly adhere to the correct pipe sizes.

PIPE LENGTH (FEET)	SCHEDULE 40 PIPE INSIDE DIA.		TUBING, TYPE L OUTSIDE DIA.	
	NAT.	L.P.	NAT.	L.P.
0-10	1/2" (1.3 cm)	3/8" (1.0 cm)	1/2" (1.3 cm)	3/8" (1.0 cm)
10-40	1/2" (1.3 cm)	1/2" (1.3 cm)	5/8" (1.6 cm)	1/2" (1.3 cm)
40-100	1/2" (1.3 cm)	1/2" (1.3 cm)	3/4" (2.0 cm)	1/2" (1.3 cm)
100-150	3/4" (2.0 cm)	1/2" (1.3 cm)	7/8" (2.3 cm)	5/8" (1.6 cm)
150-200	3/4" (2.0 cm)	1/2" (1.3 cm)	7/8" (2.3 cm)	3/4" (2.0 cm)

NOTE: Some areas allow copper tubing or galvanized pipe - check with local approval agencies and codes. NEVER use plastic pipe.

GAS PRESSURE CHECKING REQUIREMENTS

Inlet and manifold gas pressure checking taps are located on gas valve (see Figure 1 pg. 7). A qualified installer should use these fittings for setting the correct gas pressure during initial installation.

NOTE: DO NOT DAMAGE OR KINK THE FLEX CONNECTOR. CHECK FOR GAS LEAKS WITH SOAP AND WATER SOLUTION.

NOTE: 3/8" FLEX OR RIGID PIPING MAY BE USED TO CONNECT GAS SUPPLY TO UNIT DEPENDING ON STATE AND LOCAL CODES.

NOTE: BE SURE TO INSTALL FLEX GAS HOSE WITH BRASS-TO-BRASS FITTINGS TO PREVENT LEAKS AT CONNECTION.

NOTE: THE HARD PLUMBING FITTING PROVIDED IS TO BE USED WITH INSTALLATIONS REQUIRING HARD PLUMBING. IT MAY BE REMOVED IF THE FIREPLACE IS BEING INSTALLED WITH A FLEXIBLE CONNECTOR.

GAS PRESSURE REQUIREMENTS

A MAJOR CAUSE OF OPERATING PROBLEMS WITH GAS APPLIANCES CAN BE IMPROPER GAS PRESSURE!

Such problems as changes in flame color or configuration, gas pilot or burner outages, intermittent operation, changes in heat output, excessive burner noise, etc. are nearly always the result of changes in gas pressure or improper gas pressure at the time of the installation. The most important item to check during the installation and the first thing to check when problems occur is gas pressure!

Gas supplies normally enter a residence at 1/2 PSI (13" - 15" W.C.) (3. KPA). A regulator is then placed inside the residence, which drops this pressure to 7" W.C. (1.8 KPA) (Nat. Gas). This "inches to inches" regulator is of adequate capacity to service the gas appliances (such as dryer, furnace, etc.). If this regulator's capacity is not sufficient to add the Gas Fireplace, an additional "inches to inches" regulator must be installed for the Fireplace. **EXCEPTION:** Some codes allow 2-PSI (1.4KPA) supplies to enter the residence, in which case "pounds to inches" regulators are used.

The following table provides information on correct gas pressure requirements. Be sure your gas supplier or plumber carefully follows this table.

GAS PRESSURE REQUIREMENTS

	DESIRED INLET PRESSURE	MINIMUM INLET PRESSURE	MAXIMUM INLET PRESSURE	MANIFOLD OUTLET PRESSURE	AIR SHUTTER POSITION*
NATURAL GAS	7.0" W.C. (1.75 kPa)	5.0" W.C. (1.12 kPa)	11" W.C. (2.61 kPa)	3.5" W.C. (0.87 kPa)	1/8 - 1/4 " OPEN (7 mm)
L.P. GAS	11.0" W.C. (2.75 kPa)	11" W.C. (2.75 kPa)	13.0" W.C. (3.24 kPa)	10.0" W.C. (2.5 kPa)	½" OPEN-MIN. (14 mm)

TURN GAS VALVE KNOB TO "HIGH" POSITION. GAS PRESSURES MAY VARY PLUS OR MINUS 5%.

*NOTE: FOR HIGH ALTITUDE (ABOVE 5,000 FEET) SOME VARIATIONS IN AIR SHUTTER SETTINGS MAY BE REQUIRED.

Manifold pressure must be taken at the "MANIFOLD" tap and inlet pressure at the "SUPPLY" tap **with the burner operating** by a qualified installer (see Figure 1: Pressure Test Port).

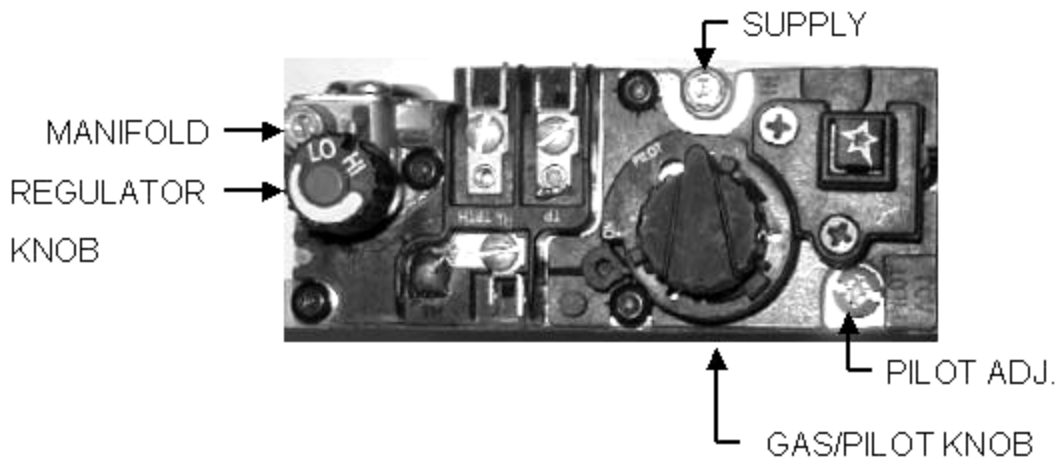

Figure 1: Pressure Test Port

EXTERIOR VENT LOCATIONS AND RESTRICTIONS

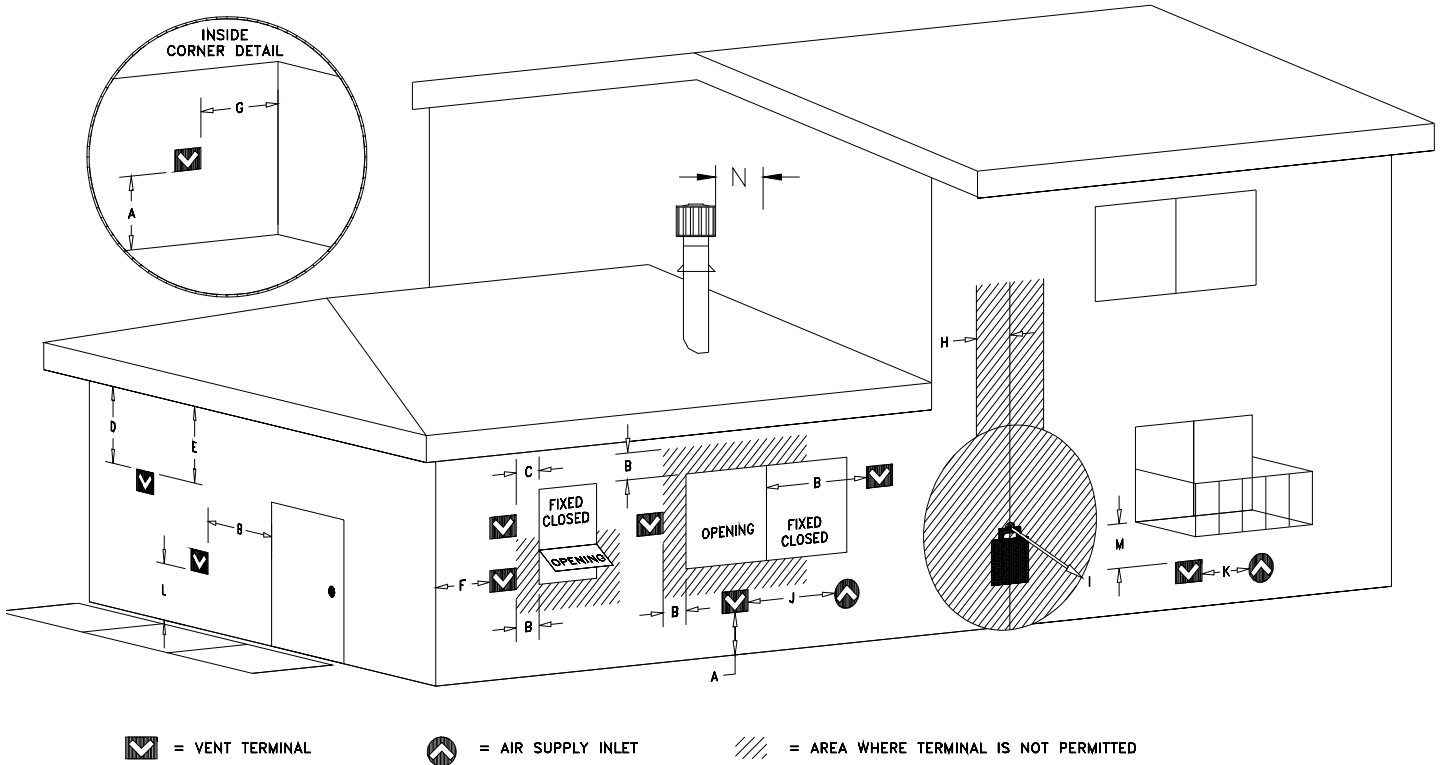

Figure 2: Exterior Vent Locations

ALL MEASUREMENTS FROM CENTER LINE OF VENT CAP

✓ - Vent Terminal

△ - Air Supply Inlet

≡ - Area where terminal is not permitted

- | | | |
|---|---|--|
| <p>A = Clearance above grade, veranda, porch, deck, or balcony (*12 inches (30 cm) minimum). Vinyl surfaces require 24" min.</p> <p>B = Clearance to window or door that may be opened (*12 inches (30 cm) minimum).</p> <p>C = Clearance to permanently closed window (minimum 12 inches (30 cm) recommended to prevent condensation on window)</p> <p>D = Vertical clearance to ventilated soffit located above the terminal from the center-line of the terminal (18 inches (46 cm) minimum) Vinyl surfaces require 24" min.</p> <p>E = Clearance to unventilated soffit (12 inches (30 cm) minimum) Vinyl surfaces require 24" min.</p> <p>F = Clearance to outside corner - 6 inches (15 cm).</p> <p>G = Clearance to inside corner - 12 inches (30 cm). Vinyl surfaces require 24" min.</p> | <p>H = *Not to be installed above a meter/regulator assembly within 3 feet (90 cm) horizontally from the center-line of the regulator</p> <p>I = Clearance to service regulator vent outlet (*6 feet (1.8m) minimum)</p> <p>J = Clearance to non-mechanical air supply inlet to building or the combustion air inlet to any other appliance. *12 inches (30 cm) minimum.</p> <p>K = Clearance to a mechanical air supply inlet (*6 feet (1.8 m) minimum)</p> <p>L = † Clearance above paved side-walk or a paved driveway located on public property (*7 feet (2.1 m) minimum)</p> <p>M = Clearance under veranda, porch, deck, or balcony (*18 inches (30 cm) minimum ‡)</p> <p>N = Minimum 24" horizontal clearance to any surface, such as an exterior surface, for vertical terminations.</p> | |
|---|---|--|

† A vent shall not terminate directly above a sidewalk or paved driveway, which is located between two single-family dwellings and serves both dwellings.

‡ Only permitted if veranda, porch, deck, or balcony is fully open on a minimum of two sides beneath the floor.

* As specified in CGA B1:19 Installation Codes (1991). **Note:** Local codes or regulations may require different clearances.

GENERAL FLUE VENTING INSTRUCTIONS

The Mendota Fireplace must be vented using the Mendota/DuraVent/American Metals venting system. All warranties will be voided and serious fire, health or other safety hazards may result from any of the following actions: Installation by unauthorized personnel; installation of any damaged component; unauthorized modification of vent system; installation of any components not manufactured or approved by Simpson DuraVent, American Metals and Mendota; failure to meet all clearance requirements; failure to properly twist-lock and positively seal all components. Consult local building codes before beginning the installation.

WARNING

Always maintain required clearances (air spaces) to combustibles to prevent a fire hazard. Do not fill air spaces with insulation. Check installation instructions for minimum clearance requirements between the outer walls of the vent pipe and nearby combustible surfaces. Be sure to check the vent termination clearance requirements from decks, windows, soffit, gas regulators, air supply inlets, and public walkways, as specified in these installation instructions and local building codes. **SAFETY PRECAUTIONS FOR THE INSTALLER:** 1) Wear gloves and safety glasses for protection; 2) Exercise extreme caution when using ladders or on rooftops; and 3) Be aware of electrical wiring locations in walls and ceilings.

The gas appliance and vent system must be vented directly to the outside of the building, and never attached to a chimney serving another solid fuel or gas burning appliance. Each direct vent gas appliance must have its own separate vent system. Common vent systems are prohibited.

To assure proper venting performance of the high-performance Mendota Direct Vent Fireplaces and Stoves, it is critical that the DuraVent GS and American Metals vent pipe sections are sealed tightly and leak-proof. This means that all pipe sections must be carefully rotated into the fully "twist-locked" position.

WE STRONGLY RECOMMEND THAT FIXED LENGTH PIPE SECTIONS BE USED IN PLACE OF TELESCOPING SECTIONS WHENEVER POSSIBLE.

Note: When using vent pipe and components that do not incorporate a fiberglass or graphite gasket at the joints, you must use Milpak 1000F silicate stove sealant (#65-06-00909). High temperature foil tape may be used on the outer (air intake) pipe joint instead of the stove sealant. Contact your dealer for proper materials. Pipe sections manufacture by American Metals do not require the use of the 1000F Silicate Stove Sealant.

DO NOT SEPARATE TELESCOPING SECTIONS. THEY MUST BE USED AS COMPLETE ASSEMBLIES.

Note: When using Dura-vent DV pipe you must use a Milpak silicate 1000F (#65-06-00909) stove sealant on all inner pipe joints. High temperature tape must be used on the outer (air intake) pipe joint. The silicate 1000F sealant can be ordered through Mendota directly.

COMPONENT "TWIST-LOCK" CONNECTION PROCEDURE

DuraVent and American Metals pipe and fittings are designed with special twist-lock connections. Twist-lock procedure is as follows: four (4) indentations, located on the female ends of pipes and fittings are designed to slide straight in to the male ends of the adjacent pipes and fittings, by orienting the four pipe identifications so that they match and slide into the four entry slots on the male ends (Figure 3).

Push the pipe sections completely together then twist-lock one section clockwise, approximately $\frac{1}{4}$ turn until the two sections are fully locked. The female locking lugs will not be visible from the outside on the black pipe or fittings. They may be located by examining inside of the female ends.

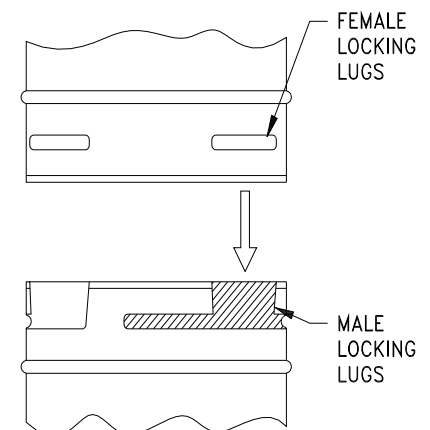

Figure 3: Twist-Lock Piping

GENERAL INSTALLATION INSTRUCTIONS

CAUTION: Each installation must conform to all local, state and national codes. Refer to the national fuel gas code and local zoning and code authorities for details on installation requirements. The Mendota Fireplace must be vented to the outside in accordance with the latest edition of the National Fuel Gas Code. In the absence of local codes, the installation must conform to the most current edition of the National Fuel Gas Code ANSI Z223.1, also known as NFPA 54. NOTE: The Mendota DXV Fireplace is approved for mobile home and bedroom installations.

CAUTION: The Mendota DXV Fireplace may be installed in a manufactured (mobile) home after the first sale of the home. Manufactured home (mobile home) installation must conform with the Manufactured Home Construction and Safety Standard, Title 24 CFR, Part 3280, or, when such a standard is not applicable, the Standard for Manufactured Home Installations, ANSI A225.1/NFPA 501A, or CSA Z240.4-Gas Equipped Mobile Housing. Consult your local building official. Note: For mobile home installations unit must be bolted to the floor and properly grounded.

The DXV Fireplace must be installed by a qualified service person.

1. After selection of the desired fireplace location, prepare the rough opening using framing dimensions on pages 12 or 22. Be sure to also prepare opening to allow for co-axial vent (see "Flue Venting Instructions" on pg. 8-19).
2. Check to make certain all venting requirements and locations are being followed (see pg. 8-19).
3. The Fireplace is designed to be installed into rough framing. The drywall will cover the adjustable nailing flanges on the Fireplace sides. Before sliding the Fireplace into the framed opening, adjust the nailing flanges to accommodate the thickness of the wall material. **NOTE: FRAMING MATERIAL ABOVE FIREPLACE MUST MAINTAIN CORRECT CLEARANCE TO VENT PIPE.**

WARNING

DO NOT COVER THE 2" BLACK FRONT SURFACE OF THIS UNIT IF YOU INTEND TO USE THE ANDOVER, BENTLEY, DEERFIELD or WELLINGTON TRIMS!!

4. Slide Fireplace into the rough framed opening. When finishing the unit, combustible materials may overlay nailing flanges and come in contact with the edges of the black front surface, but may not overlay the 2" black front surface. Noncombustible material, such as marble or brick, can be installed over the 2" black surface, **only if you are certain that a Deerfield Front, Andover Front, Bentley Front, Prairie Front or a Wellington Front is NOT going to be used as the optional trim**, up to the inside edge of black frame (next to glass). ROUGH FRAMING CAN COME NO CLOSER TO UNIT THAN THE STAND-OFFS.
5. Level the Fireplace and secure into opening by nailing through the nailing flanges on cabinet side panels. Holes are provided in fireplace floor behind grill to secure fireplace to floor using lag screws, if required. NOTE: A removable panel in the enclosure for future visual inspection of flue connection is recommended.
6. Have an electrician install a 115-Volt supply to the junction box on lower left side of the fireplace cabinet. Connect wires to the duplex outlet. This duplex outlet is removable from outside of cabinet for easy wiring. Make sure the outlet is properly grounded and that the installation conforms to all local and national wiring codes (See "Blower Operation" below, Blower Wiring Diagram, pg.42 and "Electrical Requirements," pg.4)
7. Have gas supplier or qualified plumber install gas supply line to fireplace and connect to gas nipple. Be sure gas and plumbing instructions (see pg. 6-7) and all local and national codes are carefully followed.

IMPORTANT: Any safety screen, guard, glass, grill, pressure relief cap, etc. removed for servicing a fireplace/room heater must be replaced prior to operating the fireplace/room heater.

BLOWER OPERATION

The Mendota DXV Fireplace is designed so the blower operates continually when main burner is on. The blower output can be regulated with the rheostat (included). NOTE: There will be a time delay in blower operation during "heat-up" (approx. ½ hour) and extended blower operation during "cool-down" of unit (approx. ½ hour) (see pg. 42).

OPERATION DURING POWER OUTAGES

The fireplace is designed to operate during power outages. The blower will not operate, but natural convection can be improved by removing the upper grill.

INSTRUCTIONS FOR VENTING

Read this entire section thoroughly before attempting to install this DXV35 Fireplace. Failure to follow all directions and failure to observe all restrictions and clearances can result in property damage, bodily injury or can lead to death.

TOP VENTING REQUIRES AMERIVENT, DURAVENT, SELKIRK METALBESTOS OR SECURITY CHIMNEY BRAND 4" X 6-5/8" (or equivalent) COAXIAL RIGID PIPES AND VENTING COMPONENTS.

MENDOTA DXV-35 GAS DIRECT VENT FIREPLACE SPECIFICATIONS & CLEARANCES FOR TOP VENTING

WARNING: Do not cover the 2" faceplate border of the unit with combustible materials.

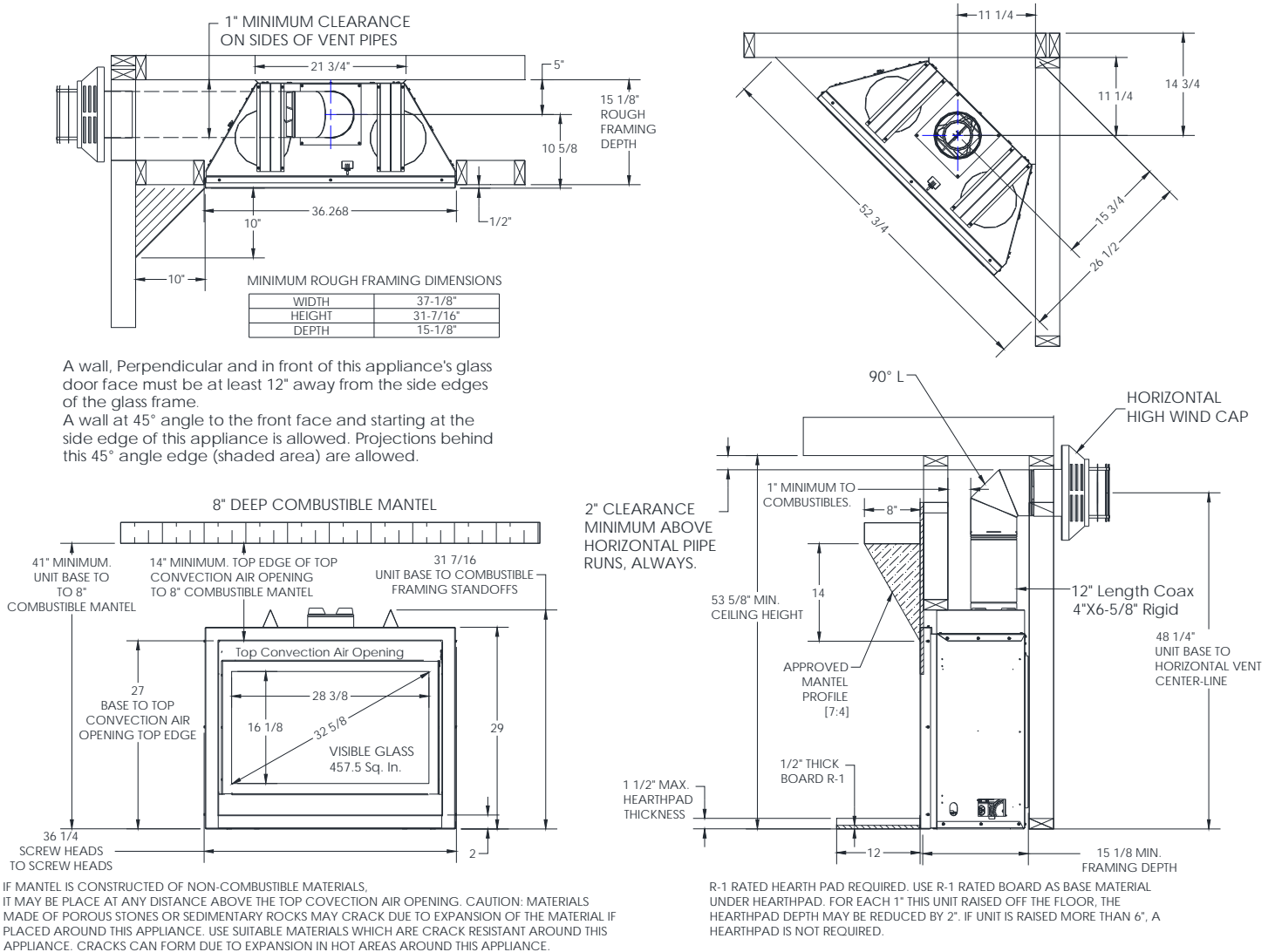

Figure 4: Specifications & Clearances

NOTE: For L.P. & High Altitude (above 4,000 ft. but below 7500 ft.), 45° elbows must be used in place of 90° elbows (see pg. 15 FOR INSTALLATION AT ALTITUDES ABOVE 7,500 FEET, FIRST CALL MENDOTA TECHNICAL HOTLINE FOR FURTHER INFORMATION ON THE STRICT REQUIREMENTS FOR INSTALLATIONS AT THESE ALTITUDES.

Using 45° elbows requires 19" minimum opening to center (see page 15 CAUTION: If 90° elbows must be used with LP or at high altitudes, a 3-foot vertical starter section must be used directly off the top of the fireplace.

TOP FLUE VENTING COMPONENTS

ITEM	DESCRIPTION
1	12" VENT STACK (MIN. 9" REQ'D")
1	24" VENT STACK (MIN. 9" REQ'D")
1	36" VENT STACK (MIN. 9" REQ'D")
1	48" VENT STACK (MIN. 9" REQ'D")
2	90° GALVANIZED ELBOW
3	45° GALVANIZED ELBOW
4	ADJUSTABLE WALL THIMBLE
5	6" or 7" PIPE (Duravent 6"/Amerivent 7")
9	ATTIC INSULATION SHIELD 12"
10	ROOF FLASHING (0/12 TO 6/12)
10	ROOF FLASHING (7/12 TO 12/12)
11	STORM COLLAR
12	VERTICAL VENT CAP
13	SUPPORT BAND
14	HORIZONTAL VENT CAP
15	FIRESTOP SPACER

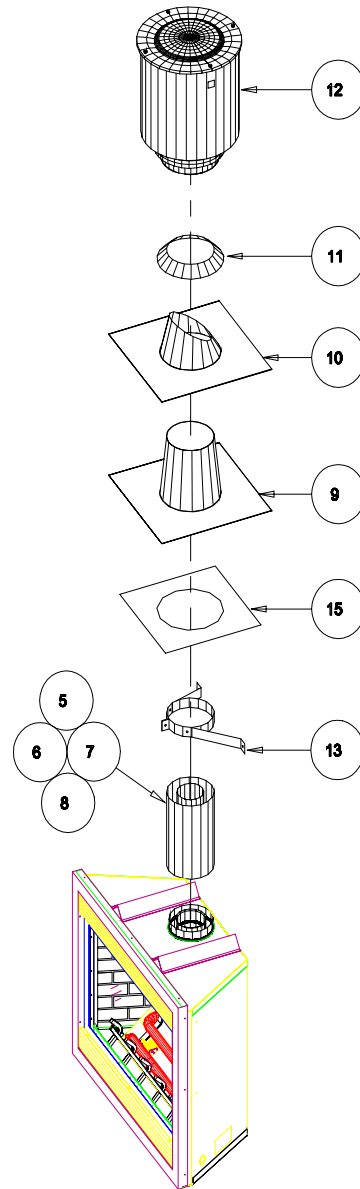
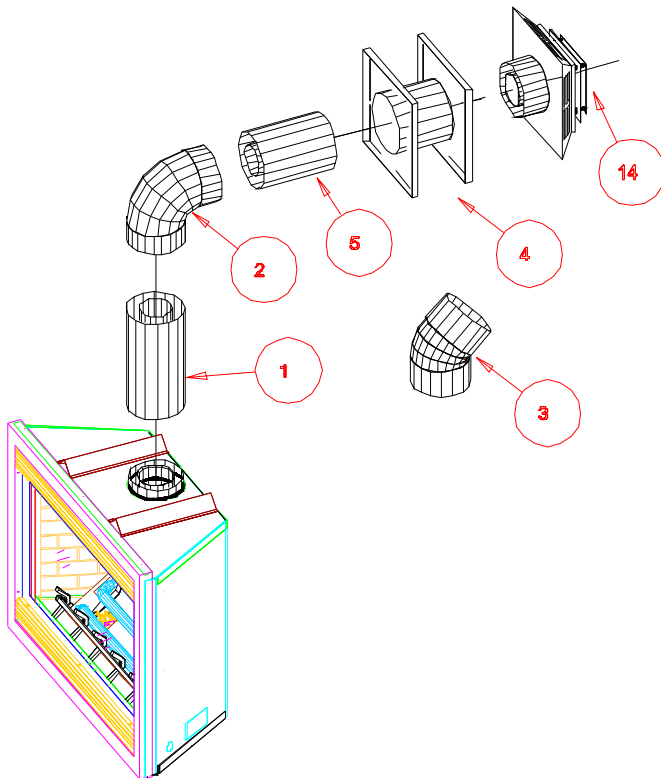

If adjustable-telescoping-pipe sections must be used, 1000° SILICATE STOVE MASONRY SEALANT must be used on the inner pipe joints. See Page 9 for additional information.

* NOTE: DO NOT SEPARATE TELESCOPING SECTIONS. THEY MUST BE USED AS COMPLETE ASSEMBLIES.

Figure 5: Flue Venting Components

FLUE VENTING REQUIREMENTS FOR TOP VENT SYSTEMS

NOTE: FOR LP GAS & HIGH ALTITUDE, SEE PG.

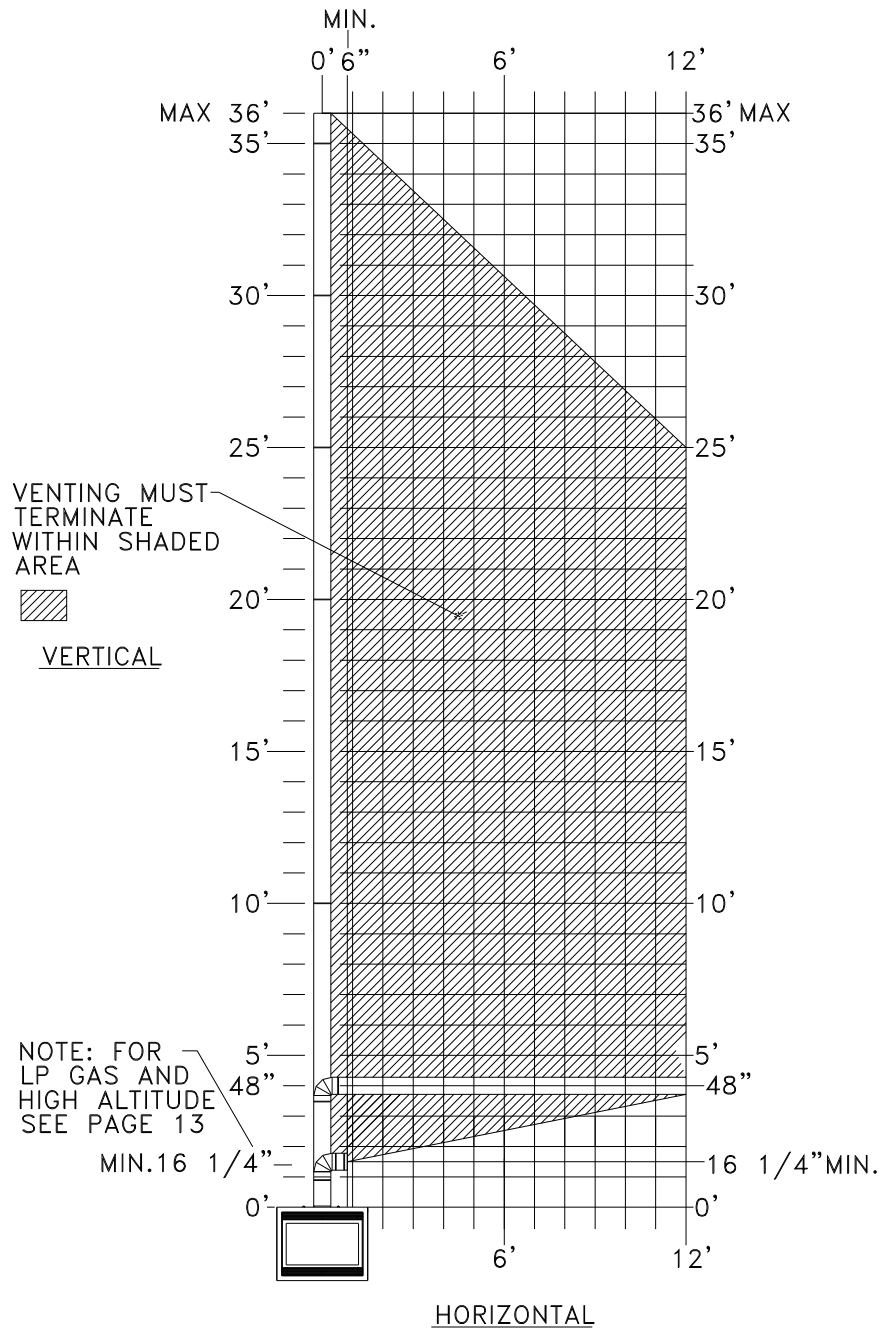

DXV-35 VENT TERMINATION
CONFIGURATION CHART

15

Figure 6: DXV35 Vertical & Horizontal Vent Requirements

*NOTE: 9" MINIMUM RISE CAN BE USED IF NO HORIZONTAL VENT SECTIONS GREATER THAN 6" (or 7") ARE USED. ALL OTHER INSTALLATIONS MUST FALL WITHIN ABOVE SHADED AREA.

L.P. GAS MINIMUM HEIGHT HORIZONTAL TERMINATION

L.P. GAS OR HIGH ALTITUDE (ABOVE 4,000 FT. BUT BELOW 7500 FT.)

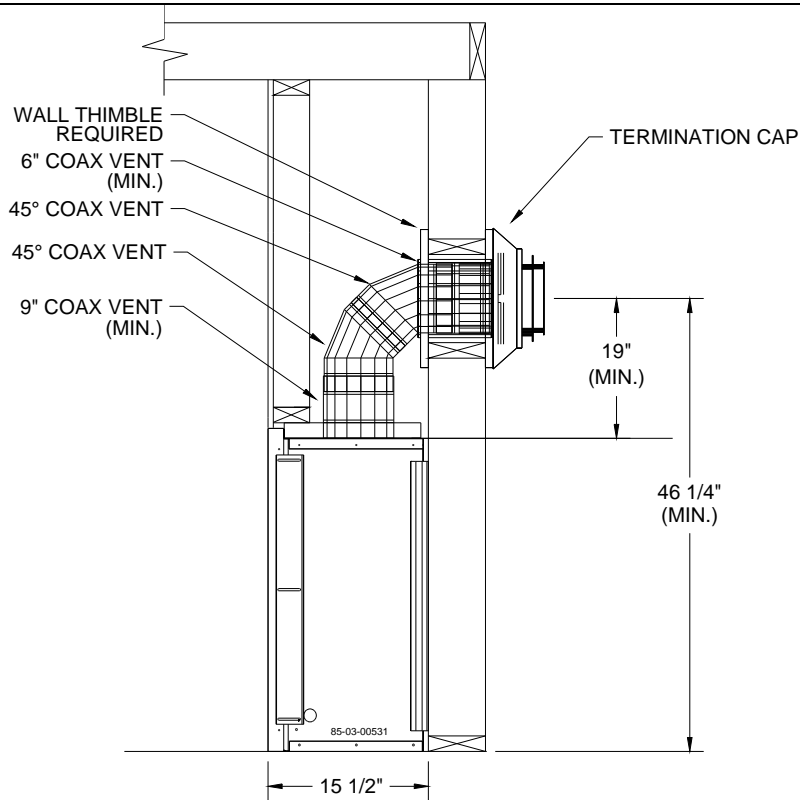

For L.P. gas and high altitude installations (above 4,000 ft.), 45° elbows must be used in place of 90° elbows.

NOTE: This requires 19" minimum height to center.

CAUTION: If 90° elbows must be used, a 3-foot vertical starter section must be used off the top of the fireplace.

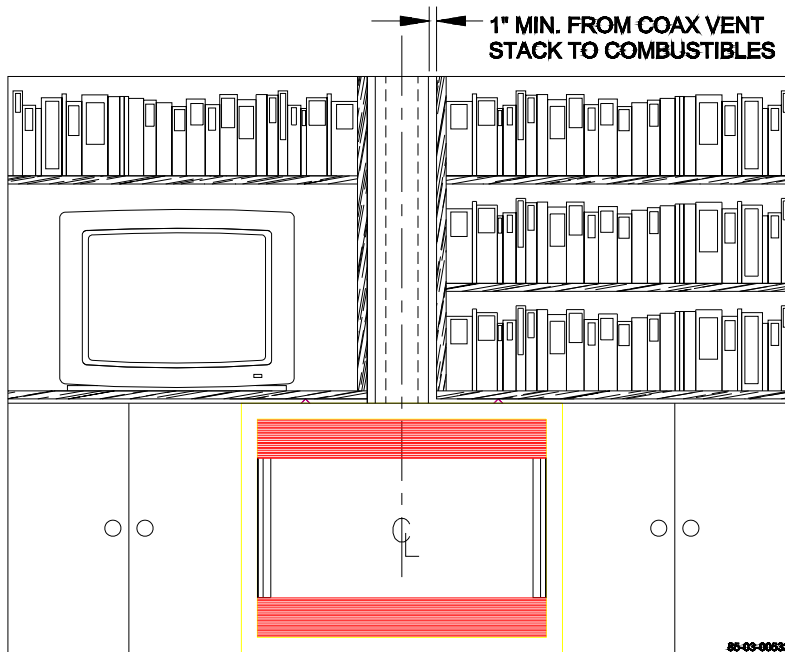

OPTIONAL SHELVING INSTALLATION

A-1 MINIMUM RISE THROUGH-THE-WALL VENTING:

The minimum vertical rise for vent installation through the wall is 16 1/4" from the top of the fireplace to the centerline of the 90° elbow in installations where only a 6" (or 7") horizontal vent section is used (refer to chart on pg.14 when using horizontal sections). NOTE: We recommend always using the most vertical rise the installation will allow. This maximizes efficiency and flame appearance. This is especially true for LP gas installations and for installations at higher altitudes. Use "fixed" pipe sections in place of adjustable pipe sections wherever possible. 1000° sealant must be used on ALL inner pipe joints. Always maintain 1" clearances from vent pipe to combustibles, 2" above pipe on horizontal runs. Do not fill air spaces with insulation or other material.

For **L.P. gas and High Altitude (above 4,000 ft.)**, 45° elbows must be used in place of 90° elbows.

NOTE: This requires 19" minimum rough opening depth (see pg. 15 CAUTION: If 90° elbows must be used, a 3-foot vertical starter section must be used directly off the top of the fireplace.

The DXV-35 Fireplace must be installed by a qualified Mendota approved service person.

IMPORTANT: REFER TO DRAWINGS ON PAGES 1215 WHILE FOLLOWING THESE INSTRUCTIONS.

1. Position fireplace in desired location. See pg. 8 for guidelines on proper vent cap placement on the exterior of home. Check to determine if wall studs are in the way when venting system is attached. If this is the case, you may want to adjust the fireplace location.
2. Measure from the top of the fireplace up minimum (see Figure 4: Specifications & Clearances, pg. 12) and mark wall directly at the center of where the vent pipe will penetrate the wall.
3. Cut and frame a 9" wide x 10" high opening in the wall. The hole must be positioned so the vent system will run level or have a 1/4" rise AND be perpendicular to the wall. The height of the opening must be located to meet all local and national building codes and not allow the termination to be easily blocked or obstructed. If wall being penetrated is non-combustible material, i.e. masonry block, brick, etc., a 7-inch diameter hole is acceptable.
4. Assemble the components to the fireplace adapter with pipe seams oriented toward the wall or floor -- as much out of view as possible. Be sure all vent component connections are in their fully twist-locked position and are leak-proof. Be sure 1000° sealant is used on the inner pipe joints of all pipe sections manufactured by Simpson DuraVent. American Metal pipe joints do not required this sealant.

- **NOTE: DO NOT SEPARATE TELESCOPING SECTIONS.**
 - **THEY MUST BE USED AS COMPLETE ASSEMBLIES.**

5. The length of the horizontal piece that fits through the wall will be determined by the thickness of the wall. When installed, the end of the horizontal piece must be flush with the exterior wall of the home. There **MUST** be a minimum of 1" air space clearance to combustibles from all vent pieces (2" above horizontal runs).
6. **A wall thimble must always be used when penetrating combustible wall materials.**
NOTE: Combustible wall thickness must be 4" to 8" maximum.
7. From the exterior of the home, slide the horizontal vent cap over the end of the horizontal pipe and tightly secure the cap to the wall with screws. Seal with a high quality caulking.
NOTE: Venting terminal should not be recessed into wall or siding.

TOP VENT COMPONENTS LIST

MENDOTA #	DESCRIPTION
45-01-00186	7" LENGTH
45-01-00187	12" LENGTH
45-01-00188	24" LENGTH
45-01-00189	36" LENGTH
45-01-00190	48" LENGTH
45-01-00191	ADJUSTABLE LENGTH
45-01-00192	45 DEG. ELBOW
45-01-00193	90 DEG. ELBOW
45-01-00194	WALL THIMBLE
45-01-00195	VERTICAL CAP
45-01-00196	HORIZONTAL CAP
45-01-00197	14" SNORKEL CAP
45-01-00198	36" SNORKEL CAP
45-01-00199	WALL STRAP
45-01-00200	FIRESTOP SUPPORT PLATE
45-01-00201	FLASHING: 0/12-6/12 PITCH
45-01-00202	FLASHING: 6/12 - 12/12 PITCH
45-01-00203	STORM COLLAR
45-01-00204	ATTIC INSULATION SHIELD
45-01-00206	CO-LINEAR APPLIANCE ADAPTOR
45-01-00207	CO-LINEAR TOP KIT
45-01-00208	VERTICAL KIT
45-01-00209	HORIZONTAL KIT
45-01-00210	HORIZONTAL KIT #2
45-01-00211	7" LENGTH- BLACK
45-01-00212	12" LENGTH - BLACK
45-01-00213	24" LENGTH - BLACK
45-01-00214	36" LENGTH - BLACK
45-01-00215	48" LENGTH - BLACK
45-01-00216	ADJUSTABLE LENGTH - BLACK
45-01-00217	45 DEG. ELBOW - BLACK
45-01-00218	90 DEG. ELBOW - BLACK
45-01-00219	FACEPLATE, CEILING SUPPORT/ WALL THIMBLE - BLK
45-01-00220	ROOF SUPPORT - BLACK
45-01-00224	36" LENGTH
45-01-00225	48" LENGTH
45-01-00226	ADJUSTABLE LENGTH

A-2. ELEVATED RISE THROUGH-THE-WALL VENTING

The required vertical rise is 48 in. when used with a maximum horizontal run of 12 ft. For other venting configurations within these maximum limits, see Figure 6, pg. 14.

NOTE: *The horizontal run of vent pipe must be level or have a ¼" rise for every 1' of run toward the termination. Never allow the vent to run downward. This will cause high temperatures and the possibility of a fire.*

USING OFFSETS AND RETURNS: A single 90° vertical-to-horizontal elbow is already calculated into the allowable maximum 12' horizontal run. Each additional 90° elbow reduces the maximum horizontal distance by 3'. Example: by using three total 90° elbows the maximum horizontal distance has been reduced to 6 ft. (3 - 1 = 2 elbows x 3' = 6'; 12' Max. - 6' of elbows = 6' of horizontal run). Note: 45° elbows reduce the maximum horizontal distance by 1½'.

SUPPORT: Horizontal runs of pipe will require one vent support for every 3 ft. of pipe.

CAUTION: If a vertical-to-horizontal elbow is enclosed within a wall, floor or ceiling, a top air space clearance of 3" must be maintained. Be sure to maintain 1" air space to any combustibles (2" above horizontal runs).

IMPORTANT: REFER TO DRAWINGS ON PAGES 12-15 WHILE FOLLOWING THESE INSTRUCTIONS.

The DXV-35 Fireplace must be installed by a qualified Mendota service person.

1. Position fireplace in desired location. See pg. 8 for guidelines on proper vent cap placement on exterior of home. Check to determine if wall studs are in the way when vent system is attached. If this is the case you may want to adjust the fireplace location.
2. Locate position where vent pipe will pass through any ceilings and will penetrate the outside wall. Since vent pipe sections "overlap" we suggest pre-assembling and measuring the total vent pipe run so you can more accurately locate the point where the vent pipe will penetrate the outside wall (See Figure 2: Exterior Vent Locations, pg. 8). Be sure all vent components are properly twist locked and leak-proof. Be sure 1000° sealant is used in the inner pipe joints of all pipe sections manufactured by Simpson DuraVent.

- **NOTE: DO NOT SEPARATE TELESCOPING SECTIONS.**
- **THEY MUST BE USED AS COMPLETE ASSEMBLIES.**

3. Cut and frame a 9-1/2" wide x 10" high openings in the outside wall openings and 9" x 9" opening in ceiling openings. The outside wall hole must be positioned so the vent system will run level or have a ¼" on rise AND be perpendicular to the wall. The height of the opening must be located to meet all building codes and not allow the termination to be easily blocked or obstructed. A ceiling fire stop spacer is required at any floor (ceiling) opening.
4. Connect vent pipe to the fireplace adapter on top of fireplace vent outlet.
5. The horizontal pipe must end flush with the exterior wall of the home. Horizontal pipe will require a proper support every 3 ft. of vent pipe. **THERE MUST BE A MINIMUM OF 1" CLEAR-ANCE TO COMBUSTIBLES FROM ALL VENT PIECES (2" above horizontal runs).**
6. **A wall thimble must always be used when penetrating combustible wall materials.**
NOTE: Combustible wall thickness must be 4" to 8" maximum.
7. From the exterior of the home, slide the horizontal vent cap over the end of the horizontal pipe and tightly secure the vent cap to the wall with screws. Seal with high quality caulking.
NOTE: Venting terminal should not be recessed into wall or siding.

B-1 VERTICAL THROUGH-THE-ROOF VENTING

The maximum vertical run of vent pipe is 36ft. from the top of the fireplace. The fireplace will support a run of a maximum of 36 ft. Maintain 1" air space clearances on all sides of vents (2" above horizontal runs).

IMPORTANT: REFER TO DRAWINGS ON PAGES 1215 WHILE FOLLOWING THESE INSTRUCTIONS.

The DXV-35 Fireplace must be installed by a qualified Mendota approved serviceperson.

1. Place the fireplace in its desired location. Drop a plum bob from the ceiling to the position of the fireplace flue exit. Mark the location where the vent will penetrate the ceiling. Drill a small hole at this point. Next, drop a plum bob from the roof to the hole previously drilled in the ceiling. Mark and drill the spot where the vent will penetrate the roof. Determine if ceiling joists, roof rafters or other framing will obstruct the venting system. You may wish to relocate the fireplace or to offset, to avoid cutting load bearing members.
2. Cut and frame a 9" x 9" opening in the ceiling centered on the hole drilled in No. 1.
3. To determine the length of the vent pipe required, measure the distance from the fireplace flue outlet to the ceiling, the ceiling thickness, the vertical rise in the attic or second story and allow sufficient vent height above roofline. For two story installations, firestops are required at each floor level. If an offset is needed in the attic, additional pipe and elbows will be required.
4. Assemble the desired lengths of vent pipe and elbows to reach from the fireplace flue outlet. Ensure that all vent pipe and elbow connections are in their fully twist-lock position and that inner pipe joints (DuraVent only) are sealed and are leak-proof. Maintain 1" airspace clearances to combustibles (2" above horizontal runs). Cut a 9" x 9" opening in the roof, centered in the small drilled hole placed in the roof in No. 1. The opening should be a sufficient size to meet all clearance requirements. Continue to assemble lengths of pipe and elbows necessary to reach up through the roofline. Galvanized pipe and elbows may be utilized in the attic, as well as above the roof line. The galvanized finish is desirable above the roofline due to its higher corrosive resistance.
 - a) If an offset is necessary, it is important to support the vent pipe every 3 ft. to avoid excessive stress on the elbows and possible separation. Wall straps are available for this purpose.
 - b) Whenever possible, use 45° elbows instead of 90° elbows. The 45° elbow offers less restriction to the flow of flue gases and intake air. If a 90° elbow is necessary there must be a minimum of one pipe section rise from the 90° elbow to the vent cap or to the next offset. A maximum of three 90° elbows are allowed per installation.
5. Slip the flashing over the pipe sections protruding through the roof. Secure the base of the flashing to the roof with roofing nails and seal flashing to roof. Ensure the roofing material overlaps the top edge of the flashing. Verify you have at least the minimum clearance to combustibles at the roofline.
6. Continue to add pipe sections until the pipe and the vent cap meet the minimum building code requirements, as outlined in No. 8 on the following page.

- a) For multi-story vertical installation, a ceiling fire stop is required at the second floor and any subsequent floors. The opening should be framed to 9" x 9" inside dimensions as described in step No. 5.
- b) Any occupied areas above the first floor, including closets and storage spaces, which the vertical vent passes through, must be enclosed. The enclosure may be framed and sheetrocked with standard construction materials, however, be sure to maintain minimum allowable clearances between the outside of the vent pipe and the combustible surfaces of the enclosure.

7. Height "*H" of top of vent cap can be determined as follows:

ROOF PITCH	"H" DIMENSION	
	FEET	METERS
FLAT to 6/12	2	.6
7/12 to 9/12	2	.6
10/12 to 12/12	4	1.2
13/12 to 16/12	6	1.8
17/12 to 21/12	8	2.4

8. Complete installation with storm collar and vent cap.

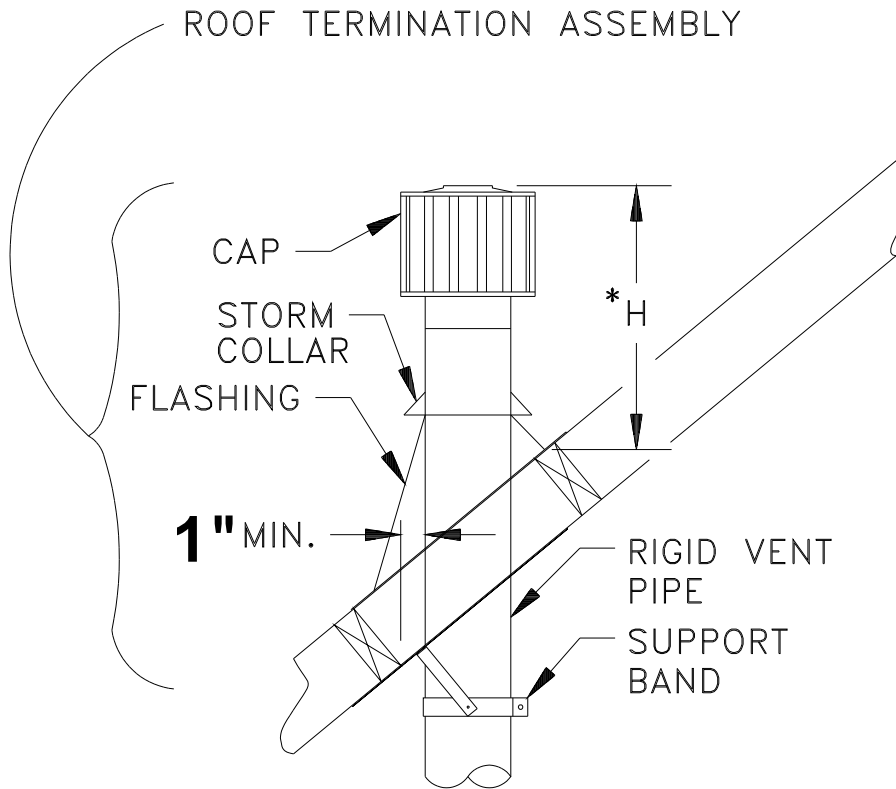

DOOR REMOVAL AND REPLACEMENT

CAUTION: Do not operate the appliance with glass removed, cracked or broken. Replacement of the glass should be done by a licensed or qualified service person. Glass latch tool #HA-57-00743 is supplied with the unit.:

To Unlatch Glass Frame Latches:

1. Insert Glass Latch Tool into hole in latch (two latches exist at top of glass frame).
2. Pull Glass Latch Tool outward about 3/8".
3. Rotate Glass Latch Tool 90 degrees.
4. Slowly Release Glass Latch Tool.
5. Remove Glass Latch Tool.

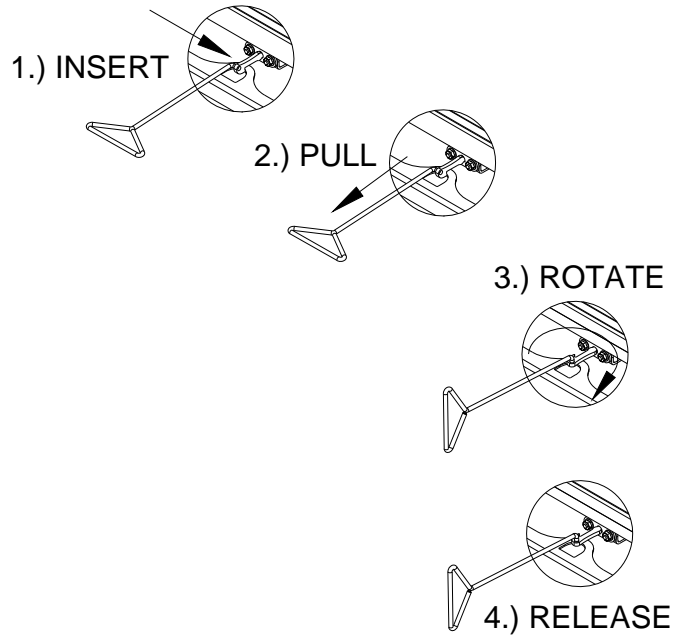

To Latch Glass Frame Latches, reverse steps 5 to 1, above.

To Remove Glass Frame:

1. Rotate top edge of freed glass frame outward about 15 degrees.
2. Lift Glass Frame Up and Out.

To Install Glass Frame:

1. Align and insert tabs in side flanges of Glass Frame into Slots into the slot in the side bracket.
2. Rotate Glass Frame upward until vertical.
3. Latch Glass in place per instructions above.

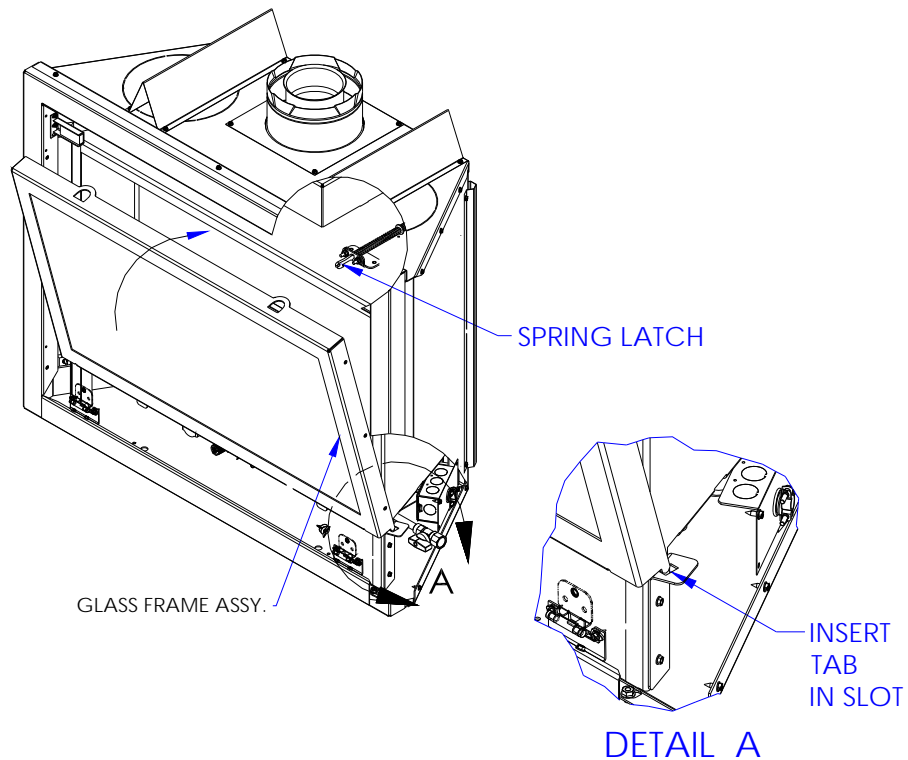

TIMBERFIRE LOG SET INSTALLATION

With door removed, proceed as follows:

1. Before placing log assembly in firebox, fill space under Log Grate with coals.
2. Follow the diagrams below in the sequence given. Start by identifying the Log Pins and Pin Hole in the Airbox. Next, identify the log pieces according to the diagram below.
3. Place glowing embers (wool) sparsely on top coals, in front of front log. Additional wool may be rubbed on front surfaces of log for additional glow. Add wool to "burned out" space between front logs. Fill area to back burner.

WARNING: Do not block holes with excessive wool. Delayed ignition and sooting can occur.

4. With glass removed, light pilot, and check for smooth ignition. Reinstall door, and check for smooth ignition. If any delay occurs, make sure that no coals or wool is blocking pilot from front or rear burner holes.
5. Reinstall door, and check for smooth ignition again. If any delay occurs, make sure that no coals or wool is blocking pilot from front or rear burner holes. Remove glass door, correct problem and repeat steps 4 and 5.

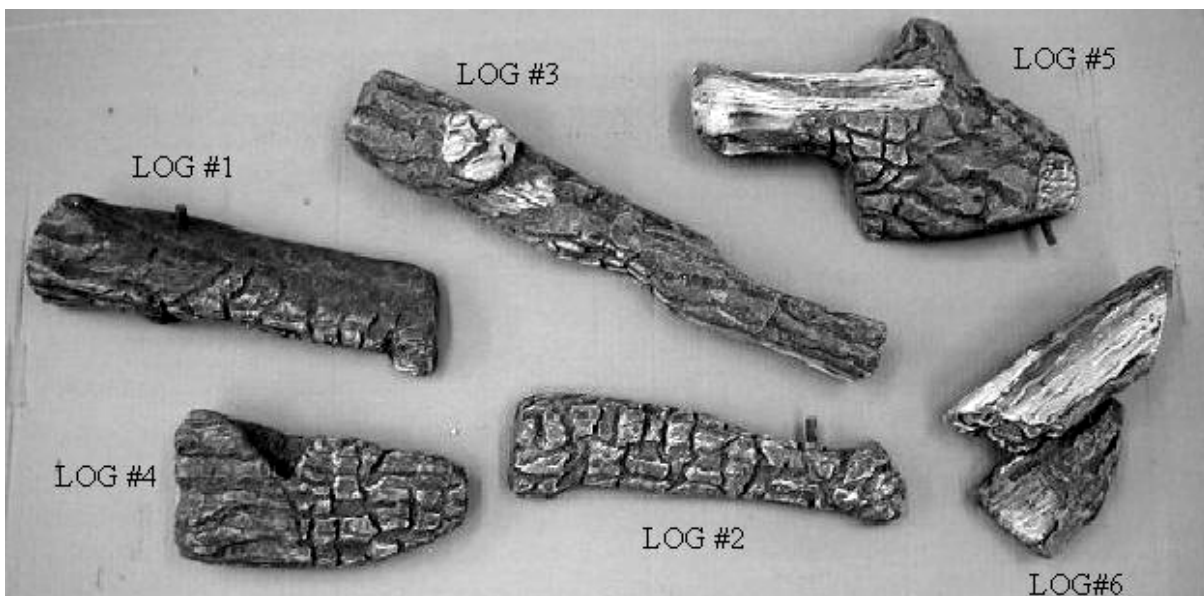
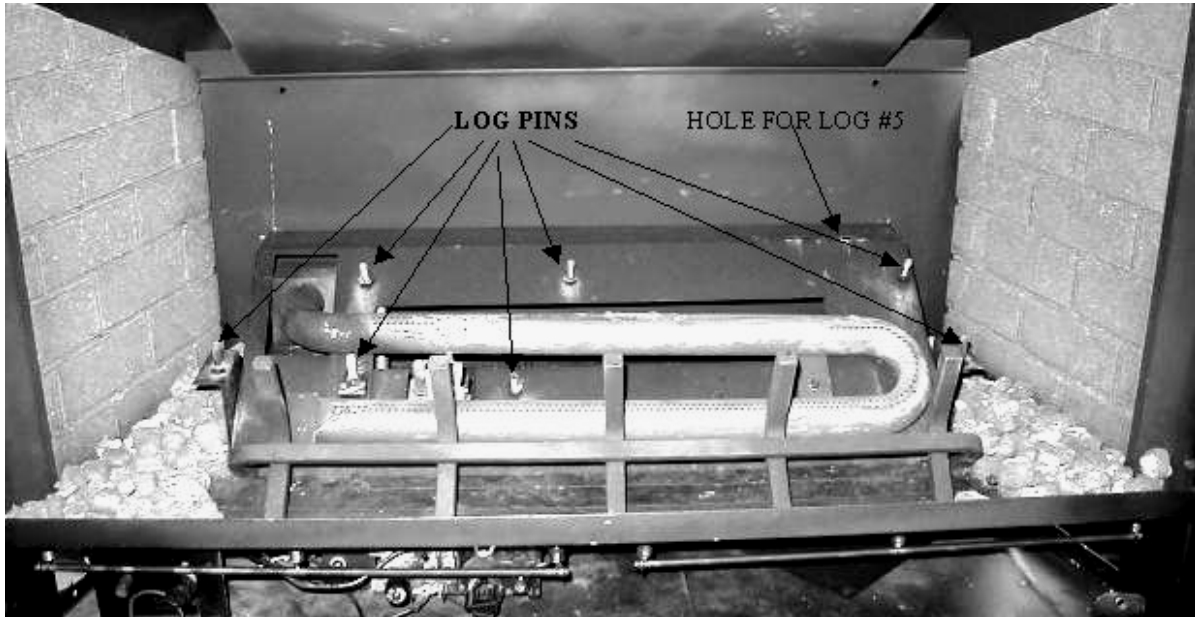

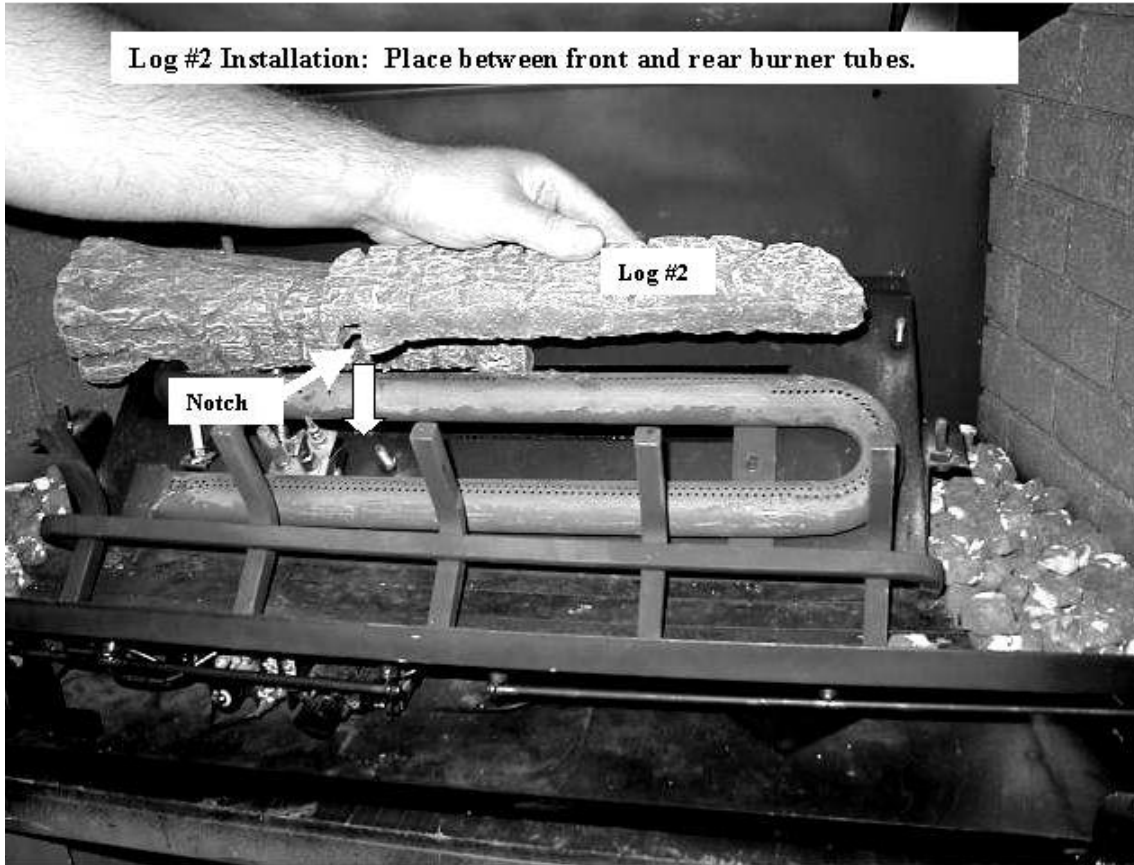
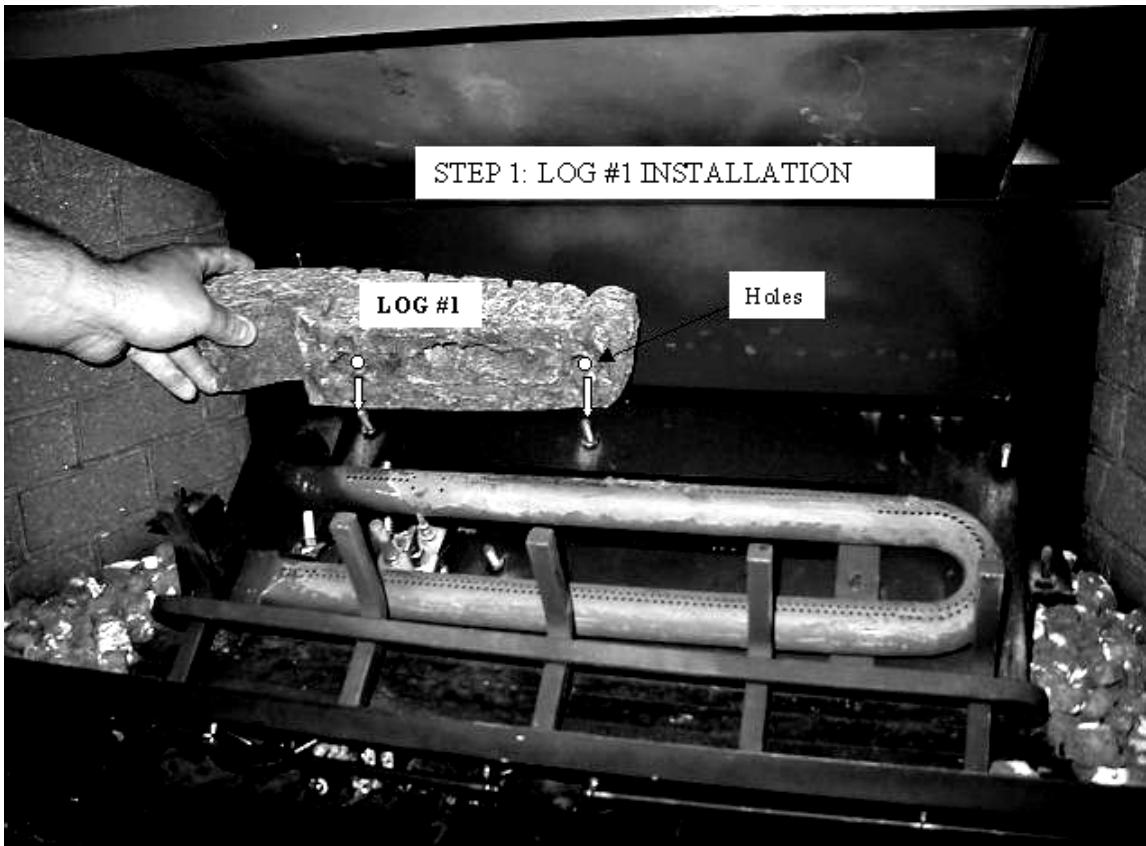

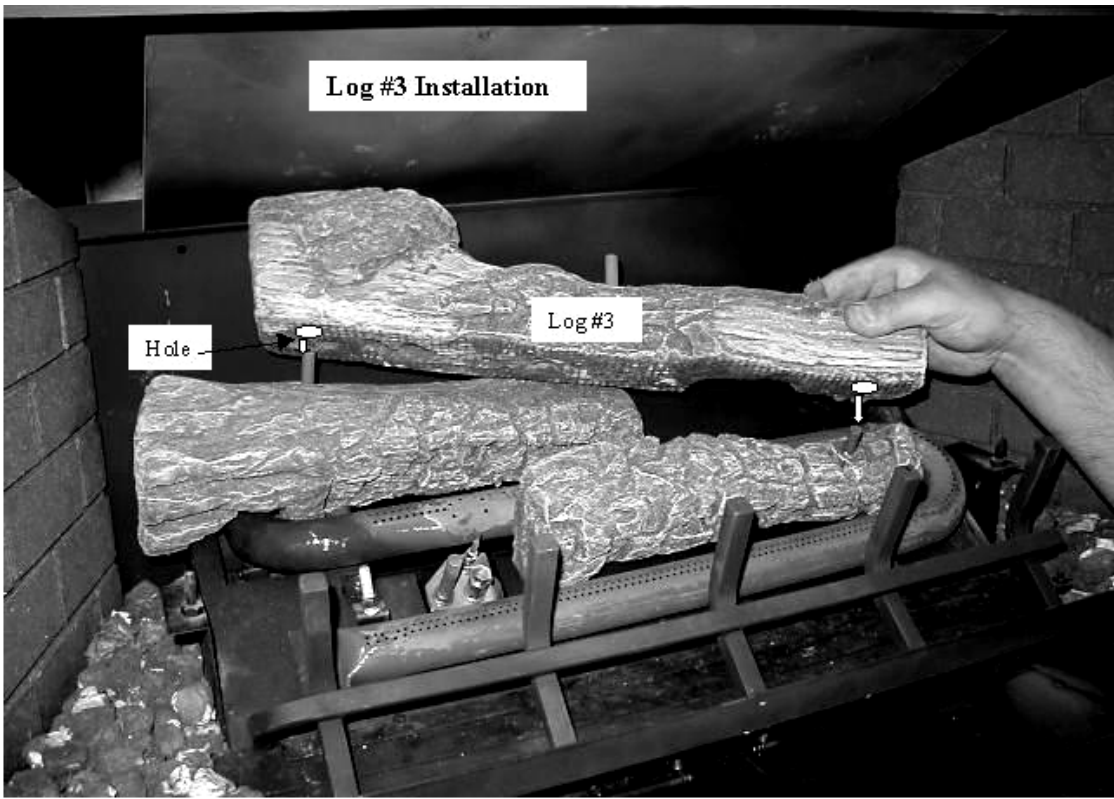

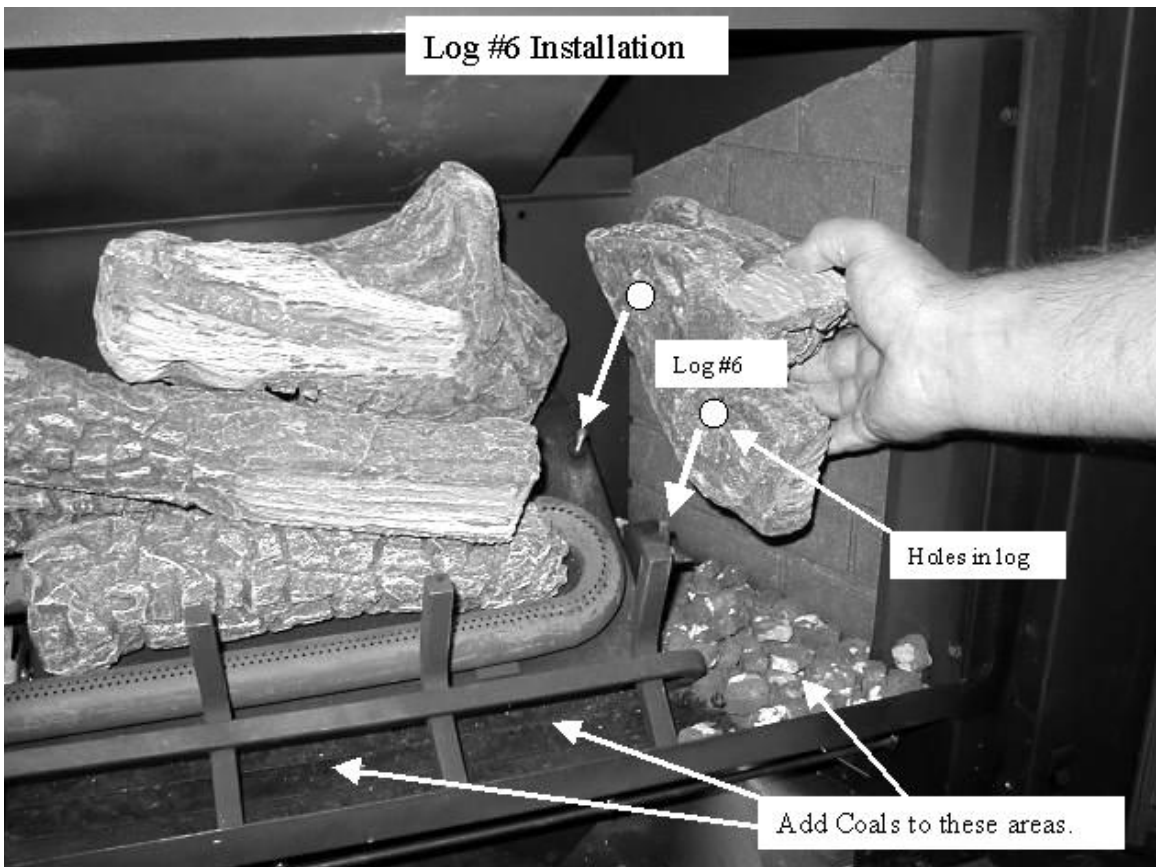
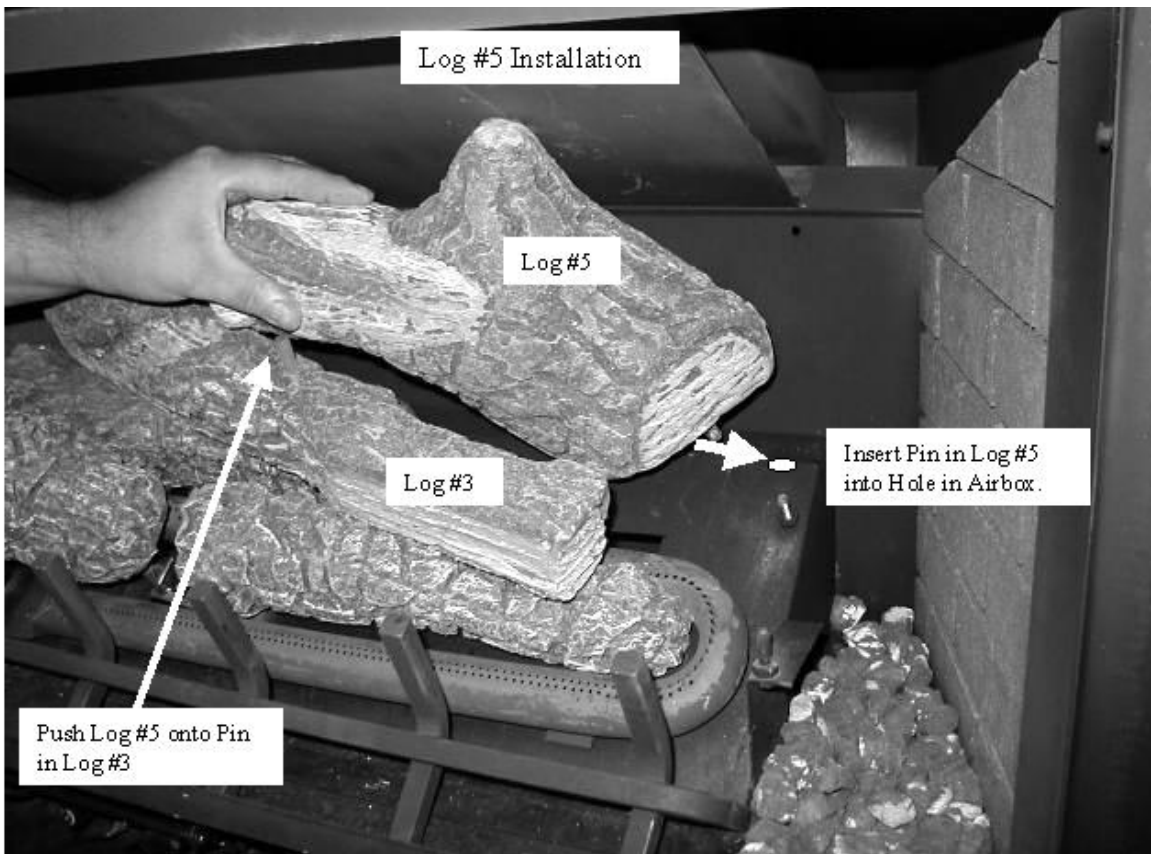

Timberfire Log Set Assembled

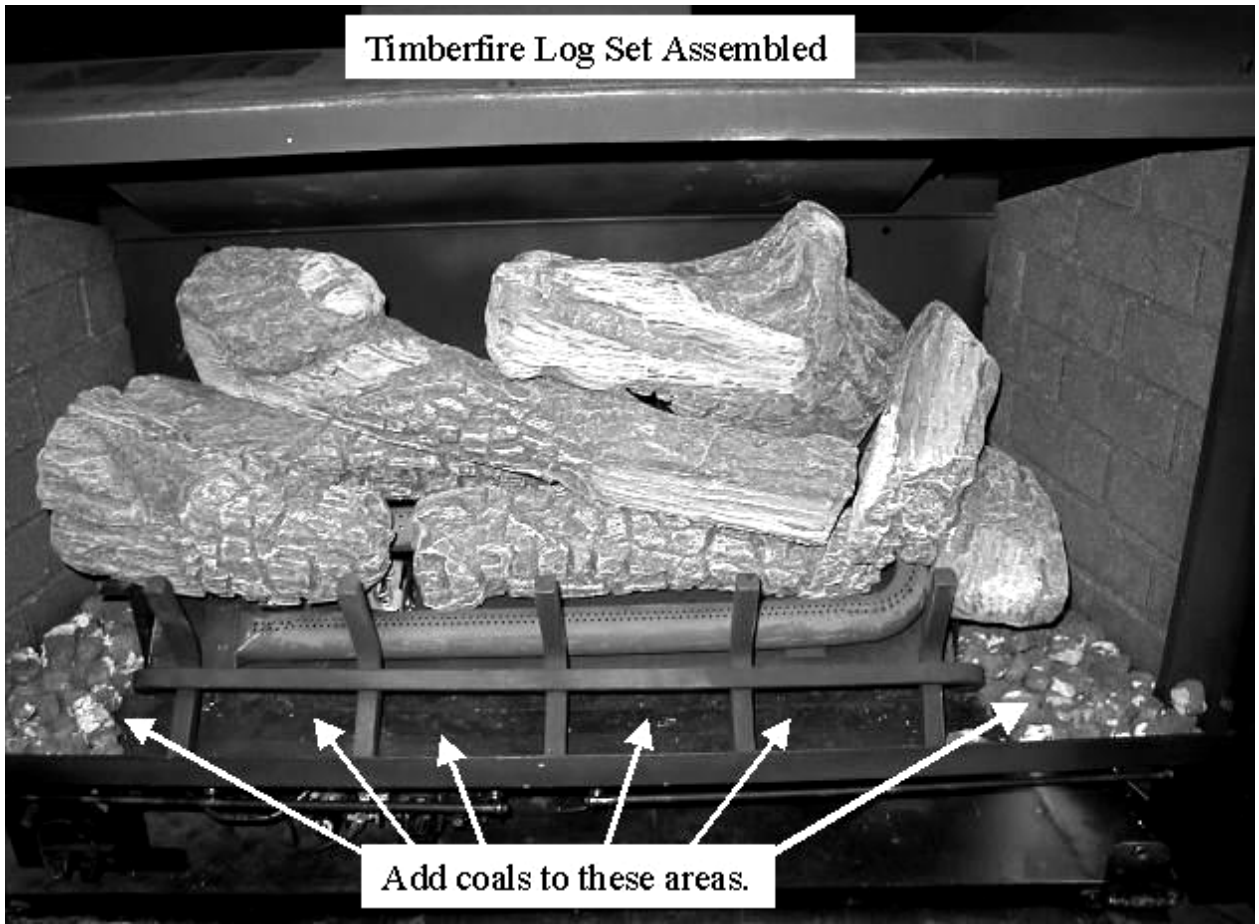

The following Check Off Lists must be completed prior to final operation of the Fireplace, or manufacturer's warranty and liabilities will be voided:

INSTALLATION CHECK OFF LIST

- Co-axial vent rigid pipe, wall vent cap or roof vent cap must be installed by a Mendota approved person in accordance with instructions. All joints must be secured, "twist-locked" and leak-proof. 1000°F sealant must be used on the inner pipe joints of all DuraVent pipe sections. Sealant is not required for Amerivent.
- Horizontal or vertical vent cap must be installed "**right-side-up**" and tightly sealed to structure per instructions. Vent Caps must be Mendota approved.
- Proper exterior and interior clearances for vent systems and locations for wall vent cap/roof vent cap must be maintained.
- Carefully check for correct gas pressure, proper size gas lines and for gas leaks.
- 115 V electrical service and gas supply must be installed in accordance with instructions and local and national codes.

LIGHTING CHECK OFF LIST

- All items on "Installation Check Off List" (see above) must be completed.
- Connect thermostat to gas valve terminals [TPTH & TH]. Use solid copper wire. See page 40 for wires specifications.
- System Millivolt readings must be taken by a qualified installer. CAUTION: Pilot flame must register a minimum of 325 millivolt.
- Check air shutter opening - 1/8" to 1/4" Nat. gas or 1/2" LP gas.
- Carefully follow all Lighting and Log Installation Instructions.
- Make certain that burner lights immediately and flame runs promptly around "curve" in burner and lights entire burner. DO NOT proceed with operation unless burner cycles "on/off" without delays.
- Make certain that the flame is "stable" and does not "lift" off burner. If flame lifts off burner, turn unit off and check that all vent pipes are "twist locked" and leak proof, the vent cap is "right side up" and that 1000° Sealant has been used on the inner pipe joints of all DuraVent pipe sections (Not required for Amerivent). DO NOT proceed with operation if flame is "lifting off" burner.
Note: do not separate telescoping sections. They must be used as complete assemblies.
- Make certain glass door is in properly closed position and "centered" in firebox opening.

LIGHTING INSTRUCTIONS

IMPORTANT: Be sure all items on "INSTALLATION CHECK OFF LIST" (pg. 39) have been completed!

CAUTION: If the pilot goes out, be sure to wait a minimum of five minutes before relighting.

BE SURE TO ALWAYS REMOVE THE GLASS BEFORE RELIGHTING THE PILOT.

1. **ALWAYS LIGHT PILOT WITH GLASS REMOVED!**

(See drawing, pg. 33 for glass door removal).

2. Make sure any gas supply shut-off cocks are open and Thermostat is "OFF".
3. Push in Gas Cock Dial Slightly and turn clockwise to "OFF". NOTE: Dial cannot be turned from "PILOT" to "OFF" unless dial is pushed slightly.
DO NOT FORCE!
4. Wait five (5) minutes to allow gas, which may have accumulated in main burner compartment to escape.
If you smell gas, STOP.
5. Turn Gas Cock Dial Counterclockwise to "PILOT" position (see Figure 7: Gas Valve).
6. Depress Gas Cock Dial and push in red Piezo igniter button. Once pilot ignites, continue depressing dial for about 1/2 minute. If pilot does not remain ignited, repeat operation allowing a longer period before releasing Gas Dial.

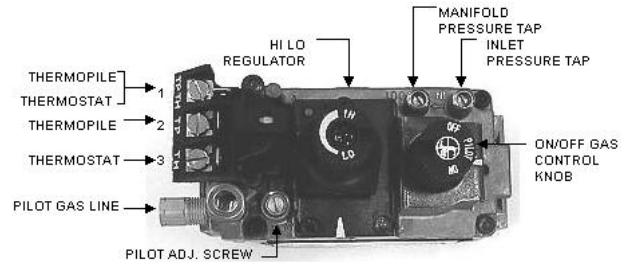

Figure 7: Gas Valve

7. After pilot is lit and before installing logs, turn Gas Dial to "ON" and "cycle" the burner on/off to make certain it ignites promptly and that the flame runs smoothly around burner curve and promptly lights entire burner.
8. With pilot operating, install log module and coals (see pg. 34-38). With logs/coals in place, "cycle" the burner again to make sure of prompt ignition of burner and that the flame runs smoothly around entire burner and does not "lift off" burner. **NOTE:** Logs will produce a strong, acrid odor on initial contact with flames (about 2 hrs.).
9. Reinstall glass front & screen by "hanging" slots on upper edge of door over tabs on upper edge of firebox opening. Then "swing in" lower edge of door. Carefully pull out the two (2) Spring Loaded Door Holding Bars located under the doorframe. Raise Bars and fit Bars firmly into Bar Holding Brackets on doorframe (see instructions, pg. 33).
NOTE: Be sure doorframe is "centered" in firebox opening. To "center": Release Door Holding Bars, with door "hanging" in upper slots "slide" door frame (within the slots) to center of firebox. Replace Door Holding Bars.
10. Turn Gas Dial counterclockwise to "ON" then set Thermostat or push Remote Control to turn on burner.
11. Main burner should now light **IMMEDIATELY** and flame should not "lift" off burner. If there is any delay in ignition or if flame is "lifting off" burner, turn off burner and carefully check for proper installation of logs/coals, vent system and proper pilot flame impingement on burner and thermopile. Logs or coals must not block pilot flame or main burner flame. Vent system must be leak proof.
DO NOT PROCEED WITH OPERATION UNLESS BURNER "CYCLES" ON/OFF WITHOUT DELAYS!
12. To reduce heat output, turn Hi/Lo Knob counterclockwise to desired temperature (see Figure 7: Gas Valve). Heat output can be reduced by up to 11,000 BTUH (1/3). Blower can also be turned down.
NEVER "over fire" by increasing BTUH above nameplate specifications.
NEVER turn down (reduce) pilot flame below the minimum 325 millivolt.
13. Open windows for first two hours of operation.

NOTICE: Initial start-up will cause some NON-TOXIC "off gassing" of adhesives, binders, paint, etc. Most nuisance odors will be eliminated after the first 2 hrs. of operation, however, slight amounts may be present during the first 24 hrs.

SHUT DOWN PROCEDURE:

1. Turn Remote Control or Thermostat to "OFF". Pilot will remain lit for return to normal service.
2. For complete shutdown turn Gas Cock Dial (see Figure 7: Gas Valve) to "OFF".

THERMOSTAT OR REMOTE CONTROL OPERATION

The Fireplace comes with a wall thermostat. The thermostat should be placed in the same room as the fireplace, approx. 4-5 ft. off the floor (out of reach of children). Do Not place thermostat near this fireplace or on an outside wall.

CAUTION: BURNER SHOULD LIGHT IMMEDIATELY AFTER TURNING THERMOSTAT "ON". IF BURNER DOES NOT COME ON IMMEDIATELY TURN THE THERMOSTAT OFF AND WAIT 60 SECONDS BEFORE TURNING ON AGAIN. IF BURNER DOES NOT COME ON IMMEDIATELY AFTER SECOND TRY RECHECK COMPLETE INSTALLATION OF LOGS, PILOT, VENT SYSTEM, ETC. TO INSURE PROPER PILOT FLAME IMPINGEMENT ON THE THERMOPILE, LOG AND COALS POSITIONING AND PROMPT BURNER IGNITION. DO NOT OPERATE FIREPLACE IF BURNER DOES NOT LIGHT IMMEDIATELY. CALL SERVICE TECHNICIAN.

NEVER TURN BURNER ON & OFF "QUICKLY" - ALWAYS WAIT 60 SECONDS!

When using remote control be sure to hold in button firmly until unit lights. DO NOT push button and release quickly before burner lights. Burner should light IMMEDIATELY and then button can be released. If unit does not light immediately release button, wait 60 seconds and repeat lighting procedure. If burner does not come on immediately after second try recheck complete installation. If necessary, contact your Mendota dealer.

NOTE: If thermostat is located over 25 ft. from fireplace the pilot flame may need to be increased up to 750 millivolt.

Use two-wire, copper lead wire per chart below and install as follows:

NOTE: *Thermostat Must Be 325-750 Millivolt Rated*

RECOMMENDED MAXIMUM LEAD LENGTH (TWO-WIRE) WHEN USING WALL THERMOSTAT (CP-2 SYSTEM)	
<u>WIRE SIZE</u>	<u>MAX. LENGTH</u>
14 GA.	100 FT.
16 GA.	64 FT.
18 GA.	40 FT.
20 GA.	25 FT.
22 GA.	18 FT.

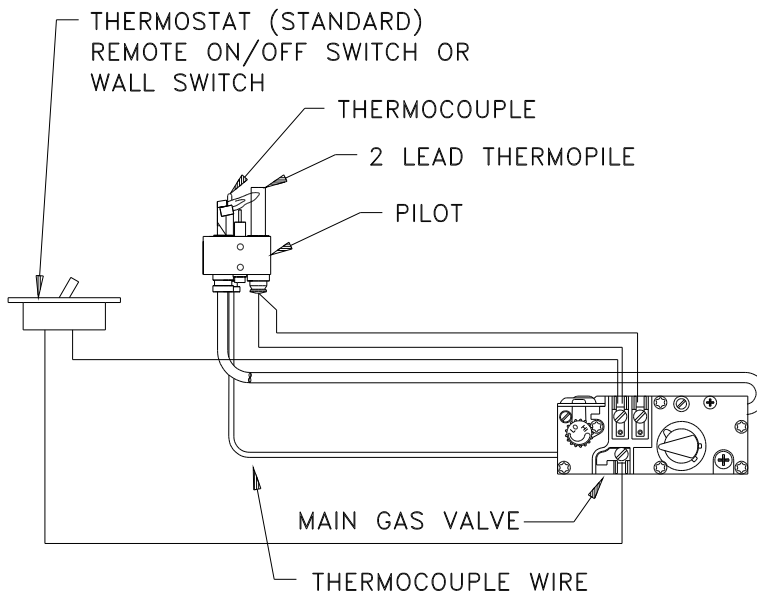

THERMOSTAT WIRING DIAGRAM

Figure 8: Thermostat Wiring

NOTE: Thermostat must be 325-750 millivolt rated.

CAUTION: THIS CONTROL IS A MILLIVOLT SYSTEM. NO ADDITIONAL POWER SUPPLY CAN OR SHOULD BE USED.

MENDOTA BLOWER & BURNER REMOVAL & INSTALLATION

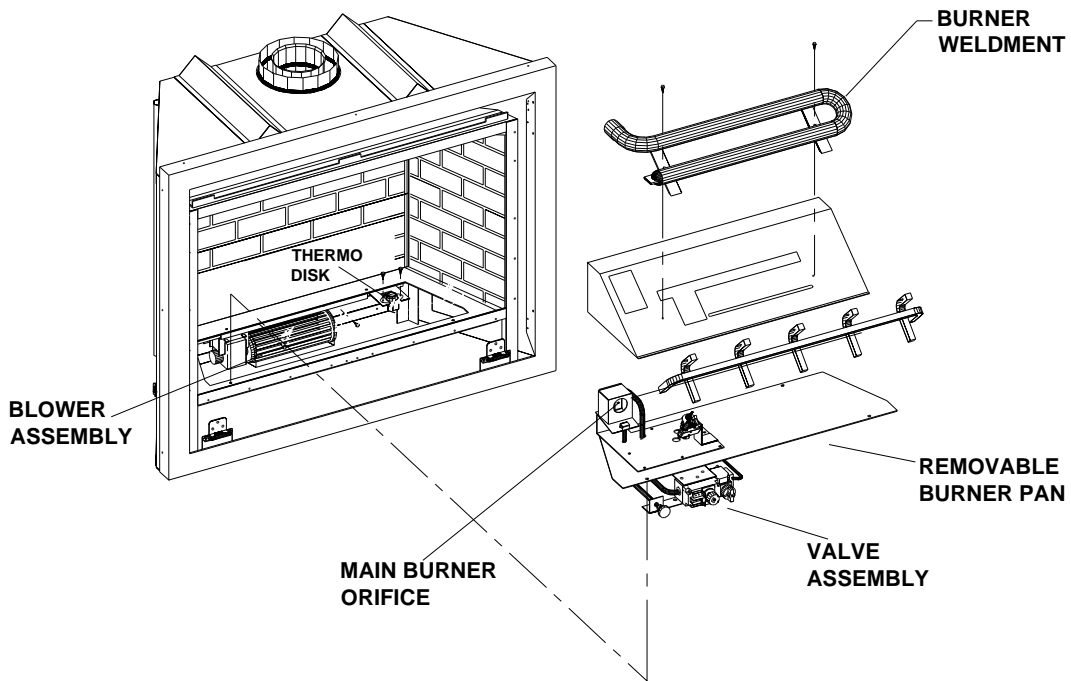

BLOWER WIRING DIAGRAM

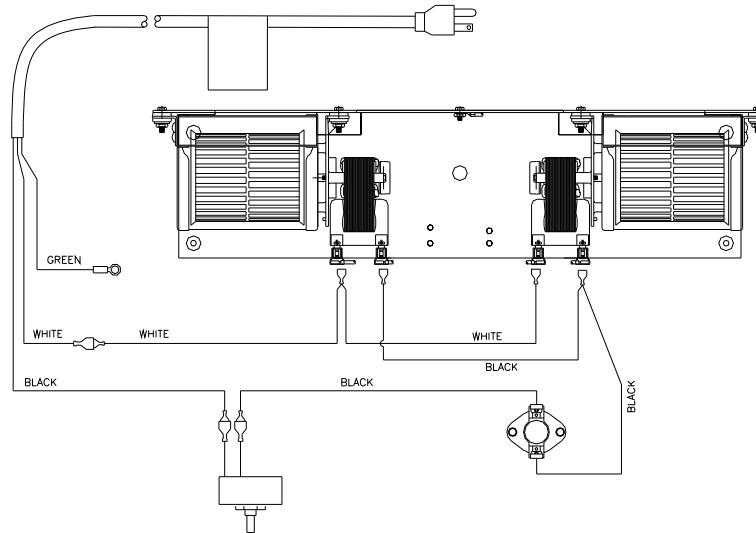

WARNING: Label all wires prior to disconnection when servicing controls. Wiring errors can cause improper and dangerous operation. Verify proper operation after servicing.

BLOWER OPERATION

The Mendota DXV Fireplace is designed so the blower operates at all times the fireplace is operating. The blower output can be regulated with the rheostat (included), but it must be "on" at all times the burner is "on". NOTE: There will be a time delay in blower operation during "heat-up" (approx. ½ hour) and extended blower operation during "cool-down" of unit. (approx. ½ hour). NOTE: Power supply to blower must be continuous. DO NOT use switch or variable control in power supplied to fireplace.

TROUBLE SHOOTING MENDOTA GAS DXV FIREPLACE

SYMPTOM	PROBABLE CAUSES	CORRECTIVE ACTION
1. Thin black coating (soot) forms on viewing glass.	A. Incorrect gas pressure B. Not enough combustion air	Have gas supplier check for correct gas pressure (7" W.C. Nat. Gas; 11" W.C. LP Gas). If sooting continues open air shutter on burner (see "Gas Flame Adjustment" below). If sooting still continues, shut off unit and call Mendota service person. NOTE: To clean glass - remove glass and wipe glass with cloth or paper towel.
2. Humming or whistling coming from Fireplace.	A. Normal operating noise.	Some noise is normal. It is caused by the gas supply flowing through the gas orifice. It is expected from any gas fireplace. Turning the Hi/Lo Knob on the control can reduce the noise. Turning down the flame will reduce the heat output of the unit.
3. A change in flame appearance or burner operation.	A. A change in gas pressure. B. Carbon dirt or lint.	Have your gas supplier check for correct gas 7" W.C. Nat. Gas; 11" W.C. LP Gas). If flame still needs adjustment see "Flame Adjustment" below. Clean out carbon, spider webs, lint, etc. from shutter area. Logs and burner. NEVER BLOCK AIR INTAKE OR OUTLET VENTS.

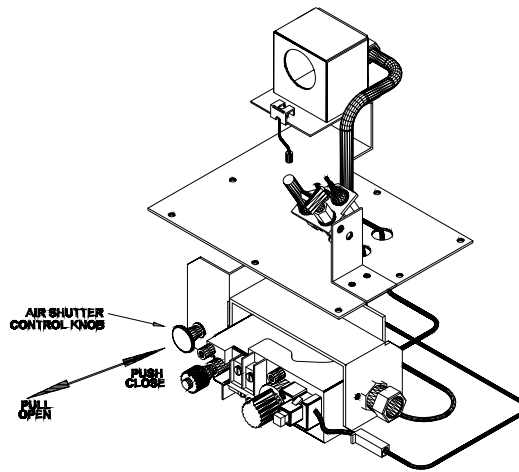

Figure 9: Air Shutter

GAS FLAME ADJUSTMENT

Be sure burner and logs are properly installed (see pg. 34-38). After burner has been properly installed and operated for two to three hours, small additional adjustments to the air shutter may be necessary for final flame appearance. These small shutter adjustments can be made by the following procedure:

NOTE: Very small changes in shutter settings make major changes in flame appearance.

1. Air Shutter Control Knob is located behind lower hinged grill.
2. Light pilot; install logs and glass, and burn unit for 1/2 hours.
3. If flame is too "blue" push Air Shutter Control Knob inward until flame turns yellow.
4. If flame is too "orange" or is causing sooting pull out knob until flame begins to turn blue. **NOTE: If sooting does not stop, turn off fireplace & call Mendota Service Person.**
5. **IMPORTANT:** Try each new shutter setting approx. 1/2 hour before making additional changes.

NOTE: Changes in front burner flame can be made by re-arranging the coals (see pg. 34-38).

CAUTION: Any changes in pilot flame must be made by qualified person and checked with voltmeter.

CUSTOMER INFORMATION AND TROUBLE-SHOOTING

MAXIMUM ALLOWABLE SURFACE TEMPERATURE

Mendota Fireplaces comply with UL Standards for maximum surface temperatures on exposed combustible surfaces adjacent to the unit. The Maximum allowable surface temperature is 117° F. over ambient (room) temperature. Thus, if a room is 70° – 80° the exposed combustible surfaces immediately surrounding the Fireplace can have a surface temperature as high as 187° F. – 197° F. (Too hot to touch). The continuous blower operation automatically keeps temperatures within these safety limits. During power outages the unit will "cycle" to prevent over-heating (see Operation During Power Failure.).

OVER FIRING OF BURNER

NEVER "over fire" units by adjusting gas pressure or drilling out the orifice to increase BTUH above name-plate specifications. Over firing can cause permanent damage to firebox and deterioration of parts and void warranty.

MAINTAINING CORRECT PILOT-FLAME -- PILOT OUTAGE & RELIGHTING

The pilot flame must be checked with millivolt meter and must always be a minimum of 325 millivolt. Never lower (reduce) pilot flame below this minimum 325-millivolt setting (see pg. 45). If pilot flame goes out, always wait 5 minutes before relighting. Always remove glass when lighting pilot.

CLEANING VIEWING GLASS

The viewing glass should be cleaned periodically. Exterior glass may be cleaned with cleaner as desired. Interior glass - use soap and water. CAUTION: Do Not use oven cleaner to clean glass.

NOTE: Additives that are put in gas (both natural and propane) to make it smell can be harmful to glass and can leave a white film deposit on the glass. This deposit can be removed with cleaners such as KEL KEM "Polish Plus" (part # 65-06-00455) or comparable product (see your dealer).

In some cases (especially propane) additives can cause "crazing" or etching on the glass. Although this is not normal, it is not covered under the warranty. The solution may be to change propane suppliers.

SOOTING

Sooting is caused by improper installation or operation. However, some small areas of soot deposits on log surfaces are deemed acceptable. If you observe large soot areas (larger than 1"x1") on log surfaces or signs of sooting on the door glass (usually a thin black film on the Fireplace viewing glass or on the outside of the home around the vent cap), the unit must be immediately turned off and the local Mendota dealer promptly informed. Mendota dealers will correct "sooting" problems, but Mendota and their dealers are not responsible for damage caused by excessive sooting that has not been immediately brought to their attention.

OPERATION DURING POWER FAILURE

The fireplace is designed to operate during power outages. Hot air convection may be improved by removing upper grill of the Millennia Fronts, opening the doors on the Andover and Prairie Fronts and opening the screen on the Wellington Front.

MAINTENANCE

1. **ANNUAL MAINTENANCE OF MENDOTA UNITS IS REQUIRED.** The following procedures must be performed each year by a Mendota approved service person. NOTE: Any adjustments to burner, pilot or logs must be done by a qualified Mendota service person.

- A. Clean all lint and dust build-up around the control. Inspect
- B. The condition of any wiring under the burner for melting or damage.
- C. Remove logs & coals and clean away any foreign matter (lint, Carbon, etc.) on the burner and logs. Be sure the burner ports are "open". Clean the pilot and under side of the logs for any Carbon deposits. NOTE: Logs should be visually checked for Carbon "build-up". If carbon deposits are visible on logs, unit should be turned off and Mendota service person contacted. Be sure logs are re-installed per instructions on [pages 34-38](#).

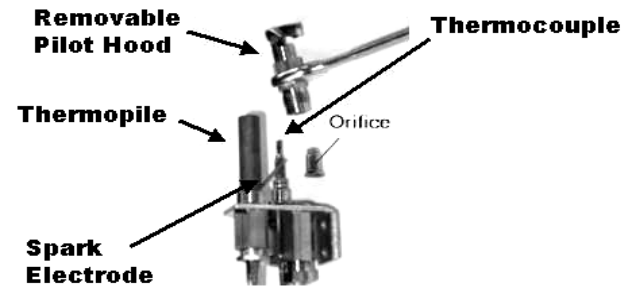

- C. Make sure hot air outlet grills are free from lint and other obstructions. Never block or obstruct grill openings. Check condition of gaskets, gaskets must be tight, replace if necessary.
- D. Check that chimney flue and outlet are open and free of blockage.
- E. Before re-installing glass, have qualified service person check the operation of the pilot with millivolt meter and cycle the burner per LIGHTING INSTRUCTIONS (see pg. 40). Pilot must read a minimum of 325 millivolt. Be sure all items in LIGHTING and INSTALLATION "check off " lists are completed (see [pg. 39](#)).

2. **COMBUSTION SYSTEM MILLIVOLT READING:**

Millivolt readings must be taken by a qualified installer at the time of installation and after any interruption in burner operation. These readings will establish proper thermopile millivolt generation and assure trouble-free burner operation. Readings must be taken with: a.) Pilot ONLY operating. b.) Main Burner operating.

- A. **PILOT ONLY OPERATING - Thermostat "OFF"** - Minimum Millivolts 325
Using a Millivolt Meter, a millivolt reading should be taken by attaching Meter leads to terminals #1 and #2 on the main gas valve. The Meter must read a minimum of 325 millivolts with the Pilot Light operating, Thermo-stat turned "OFF" and Main Burner "OFF". To increase or decrease millivolts, (and pilot flame) adjust pilot screw on control.
- B. **MAIN BURNER OPERATING - Thermostat "ON"** - Minimum Millivolts 100
Using a Millivolt Meter a millivolt reading should be taken by attaching Meter leads to terminals #2 and #3 on the millivolt panel on the main gas valve. The Meter must read a minimum of 100 millivolts with the Gas Cock Dial turned "ON", Thermostat "ON" and Main Burner operating. To increase or decrease millivolts (and pilot flame) adjust pilot screw on control.

CHECK TEST	TO TEST	CONNECT METER LEADS TO TERMINALS	THERMOSTAT CONTACTS	METER READING SHOULD BE
A	COMPLETE SYSTEM	2 & 3	CLOSED	100MV OR MORE
B	THERMOPILE OUTPUT	1 & 2	OPEN	GREATER THAN 325 MV
C	VALVE SYSTEM RESISTANCE	1 & 3	CLOSED	LESS THAN 2.8 OHMS
D	AUTO/PILOT DROPOUT	1 & 2	OPEN	BETWEEN 120-30 MV

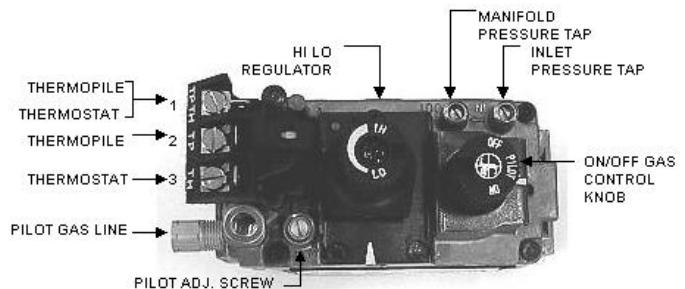

3. **THE VIEWING GLASS SHOULD BE CLEANED PERIODICALLY.** Exterior glass may be cleaned with cleaner as desired. Interior glass - use KEL KEM "Polish Plus" (part # 65-06-00455) or comparable product. Do Not use oven cleaner or abrasive cleaners to clean glass. DO NOT CLEAN WHEN GLASS IS HOT.
4. **PERIODIC VISUAL CHECK OF PILOT FLAMES IS REQUIRED.**
6. **PERIODIC VISUAL CHECK OF MAIN BURNER'S REAR AND FRONT FLAMES IS REQUIRED.**

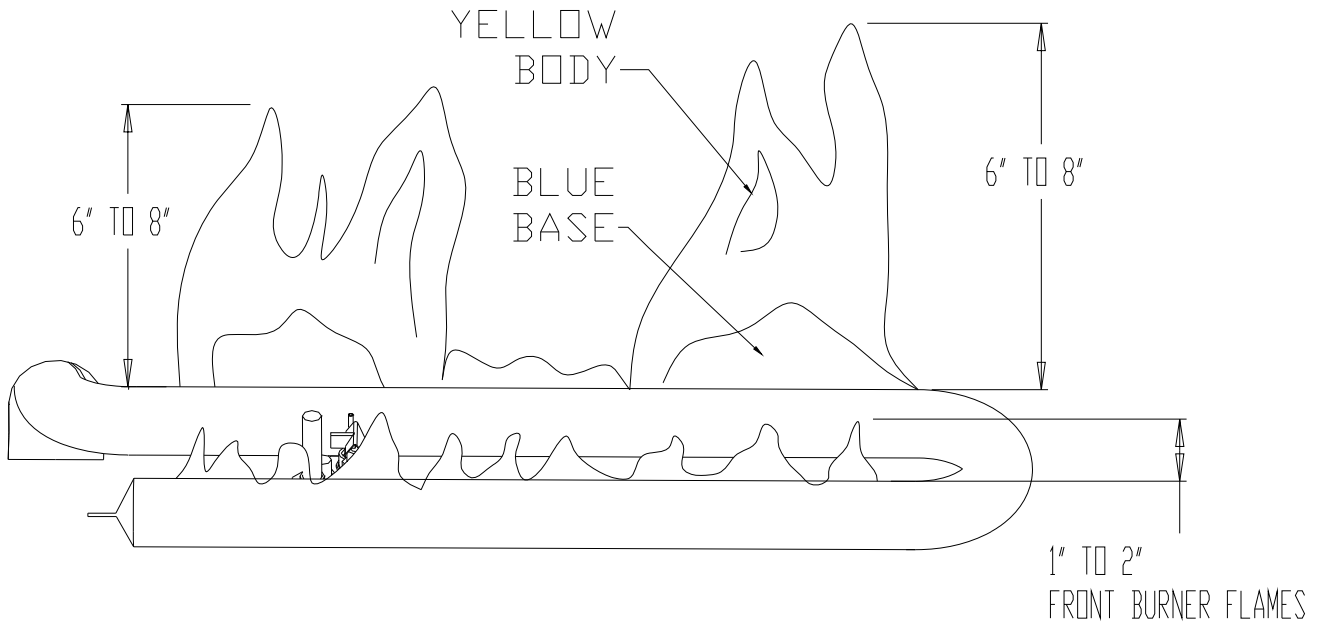

NATURAL TO LP GAS CONVERSION

HA-30-00237 (OPTIONAL)

This conversion must be made by a qualified service technician.

1. Install main burner orifice #65-14-00050 (#50 drill) see pg. 42 for location. Orifice is removed and installed with a ½” deep well socket and ratchet.
2. Install pilot orifice #05-04-00036 (.014”) see pg. 45 for location. Remove and install pilot hood with 7/16” open-end wrench. (Pilot orifice thimble is located inside pilot hood base.)
3. Install the new LP Pressure Regular onto the gas valve body in the same position and orientation as the NG Pressure Regular you removed in Step 2, above. The LP Pressure Regular can only be mounted in one position. Secure the LP Pressure Regular in place using the 3 screws you removed in Step 2. Tighten down using a ¼” flat blade screwdriver.

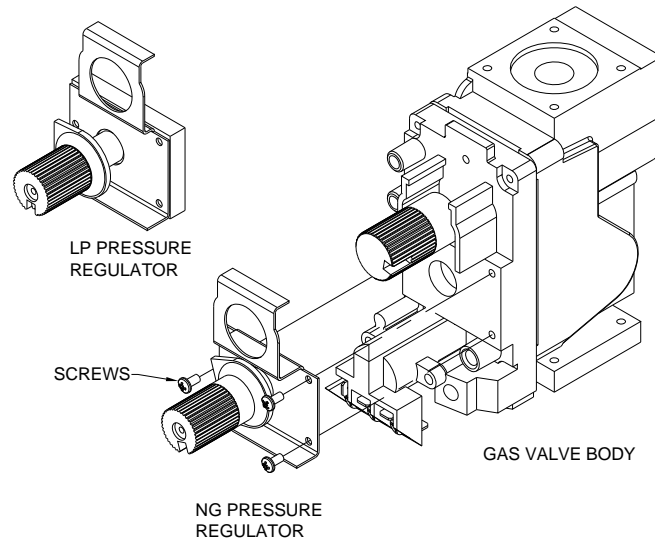
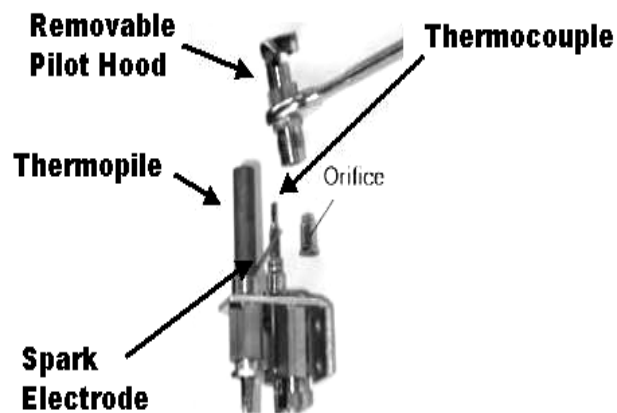

REPLACEMENT PARTS
MENDOTA GAS DXV-35 FIREPLACE

PART NO	DESCRIPTION	PART NO	DESCRIPTION
HA-29-00035	DOOR GASKET	05-04-00035	PILOT ASS'Y. NAT.
		05-04-00036	LP PILOT ORIFICE
65-06-00463	GLASS – FLAT	05-07-00067	THERMOCOUPLE
HA-30-00012	DOOR FRAME ASS'Y. – FLAT		
		HA-29-00028	MAIN ORIFICE (Nat. Gas) # 32
65-06-00623	GLASS – BAY	HA-29-00029	MAIN ORIFICE (LP Gas) # 50
HA-30-00040	DOOR FRAME ASS'Y - BAY		
		65-06-00149	PIEZO IGNITER
35-01-00268	6 PIECE TIMBER FIRE LOG SET	05-07-00061	THERMOPILE
35-01-00240	COALS 12 OZ bag FOR 1 PC LOG SET	05-01-00118	THERMOSTAT (Wall Mount)
35-01-00239	GLOWING INSWOOL		
		10-01-00003	RHEOSTAT
35-01-00275	FIREBRICK KIT		
		15-02-00062	BLOWER ASS'Y.
HA-30-00230	VALVE ASS'Y SIT	15-02-00064	R H BLOWER WITH MOTOR
05-02-00306	VALVE NAT GAS	15-02-00065	L H BLOWER WITH MOTOR
		05-01-00157	THERMO-DISC (Snap Disc-Blower)
HA-30-00088	BURNER TUBE WELDMENT	65-06-00125	BLACK PAINT - 12 OZ. SPRAY CAN
		65-06-00455	KEL-KEM Glass Cleaner/Polish
05-02-00283	ON-OFF EXTENSION KNOB		
05-02-00284	HI-LO EXTENSION KNOB		

WARNING: Use only authorized parts and materials obtained from Johnson Gas Appliance when replacing defective or damaged glass.

DO NOT substitute other manufacturer's materials or components.

DO NOT operate unit with cracked, broken or missing glass.

WARNING: DO NOT OPERATE THIS APPLIANCE WITH THE GLASS REMOVED, CRACKED OR BROKEN. REPLACEMENT OF GLASS SHOULD BE DONE BY A LICENSED OR QUALIFIED PERSON.

MENDOTA DESIGNER FRONTS INSTALLATION INFORMATION

The following Designer Fronts are available for the DXV-35 Fireplace:

1. Andover, Bentley Arched Door Kit or Prairie Rectangular Door kit with Fire screen with optional Overlays as listed below:
 - a. Black Overlay
 - b. Pewter Overlay
 - c. Antique Copper Overlay
 - d. 24K Gold
2. Wellington Fire screen Front
3. Black or 24K Gold Victoria Filigree
4. Black or 24K Gold Tuscany Filigree
5. Millennia Flat Grills in four optional color schemes as listed below:
 - a. Black Millennia Flat Grills
 - b. Full Brass Millennia Flat Grills
 - c. Classic Black and Brass Millennia Flat Grills
 - d. Classic Black and Bright Silver Millennia Flat Grills

Information specific to the installation of the Andover, Bentley and Prairie Fronts

The Andover Door and Prairie Door Fronts are designed to be “Full-Face” trim kits. These two Fronts cover an area equivalent to that shown in the diagram below. Any material that protrudes into this area on the sides, top or bottom edges can only be flush with the front surface of the fireplace faceplate.

If planning to install either the Andover Door or the Prairie Door Front, **DO NOT COVER THE FACEPLATE OF THE FIREPLACE WITH ANY MATERIALS.** Furthermore, any drywall or wall covering material that is adjacent to the sides, top or bottom of the Fireplace’s faceplate may not protrude out past the front surface of the Fireplace Faceplate’s front surface.

The Andover, Bentley and Prairie Doors Mounting Faceplate (required for installation of the Andover, Bentley and prairie Doors) may be covered over with noncombustible facing materials. See Figure 18, below.

To install Tile, Marble, Slate, Stone, Rocks or other noncombustible facings to enhance the arch shape of the Andover Doors or the Rectangular shape of the Prairie Doors, do so only after the Andover or Prairie Door Kits have been installed on the DXV-35 Fireplace.

WARNING: COMBUSTIBLE MATERIALS MUST NOT COVER THE FRONT SURFACE OF THE FIREPLACE’S FACEPLATE.

Figure 10

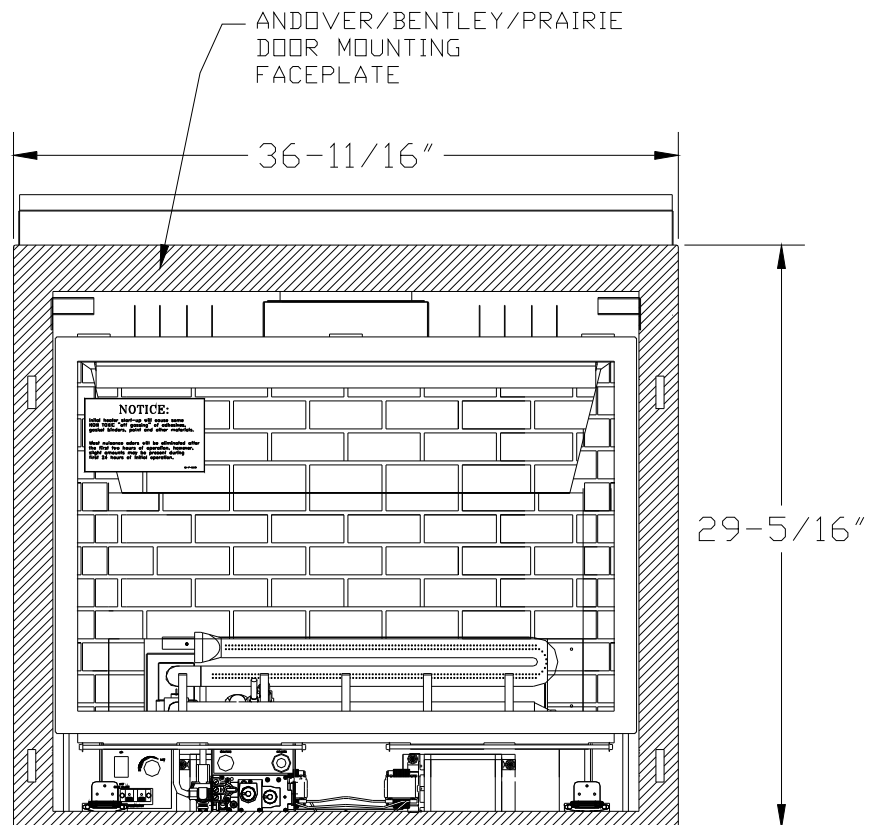

Information specific to the installation of Millennia Flat Grills, Victoria Filigrees and Tuscany Filigrees

The Millennia Flat Grills, Victoria Filigree and Tuscany Filigree are designed to be “inside-fit” trim kits. All of these trim kits fit within the inner perimeter of the Fireplace’s Faceplate and remain flush within the Faceplate’s front surface, see Figure below. This fitting method allows flexibility in covering the black visible surface of the Faceplate with non-combustible materials such as Tile, Marble, Slate, Stone and Brick; as long as enough room is allowed for the removal of these Mendota Designer Fronts and the glass door for servicing,

WARNING: COMBUSTIBLE MATERIALS MUST NOT COVER THE FRONT SURFACE OF THE FIREPLACE’S FACEPLATE.

Figure 11

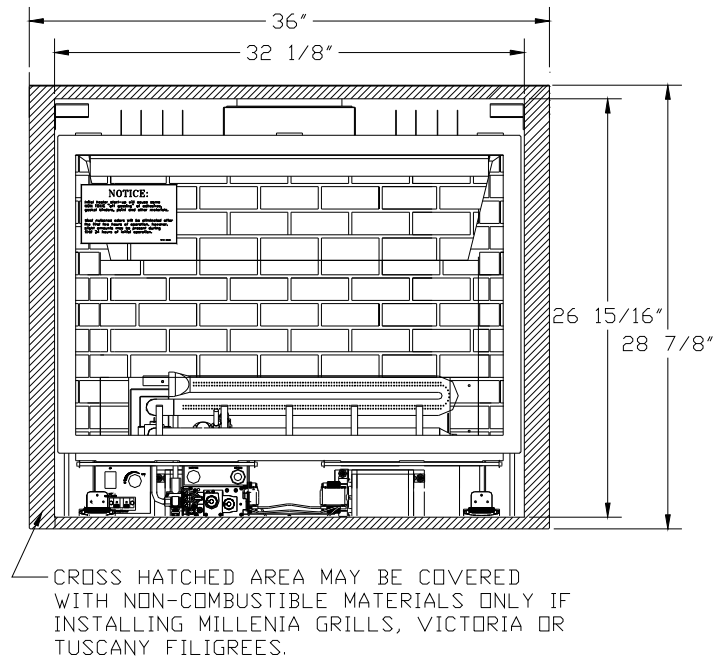

Information specific to the installation of the WELLINGTON FIRESCREEN FRONT:

The Wellington Fire screen Front is designed to be an “inside-fit” trim. The top and sides of these trim kits fit within the inner perimeter of the Fireplace’s Faceplate. The bottom member of this trim, however, overlaps the bottom 2” black boarder of the fireplace front faceplate. Therefore, DO NOT COVER THE BOTTOM 2” BOARDER OF THE FIREPLACE FACEPLATE WHEN INSTALLING THE WELLINGTON FIRESCREEN TRIM. The sides and top edges of the black visible surface of the Faceplate may be covered with non-combustible materials such as Tile, Marble, Slate, Stone and Brick; as long as enough room is allowed for the removal of this Mendota Designer Fronts and the glass door for servicing,

Figure 12

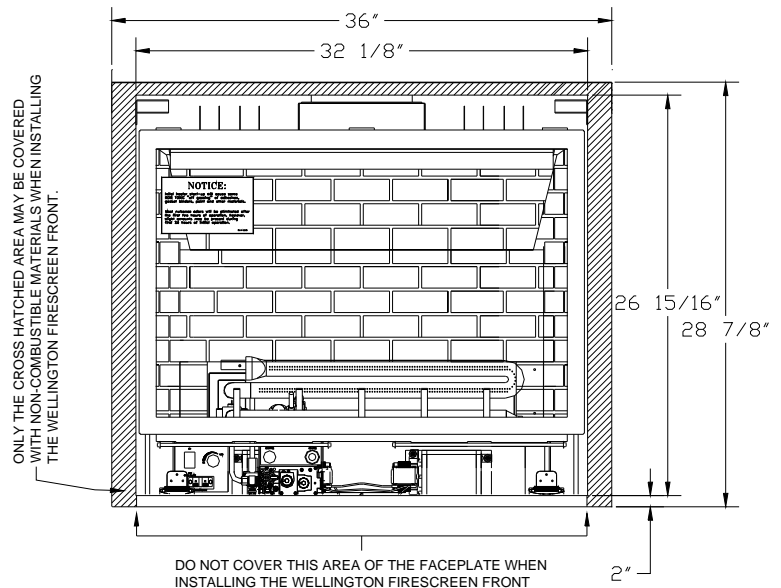

Hearth Protection Pad Installation Information when planning to install the Wellington Front and Deerfield Front.

If planning to install the Wellington Front, the hearth protection pad installed in front of the DXV-35 Fireplace must be designed, built and installed so that the hearth protection pad’s top surface is flush with the bottom-most surface of the DXV35 Fireplace. See FIGURE 16.

Figure 13

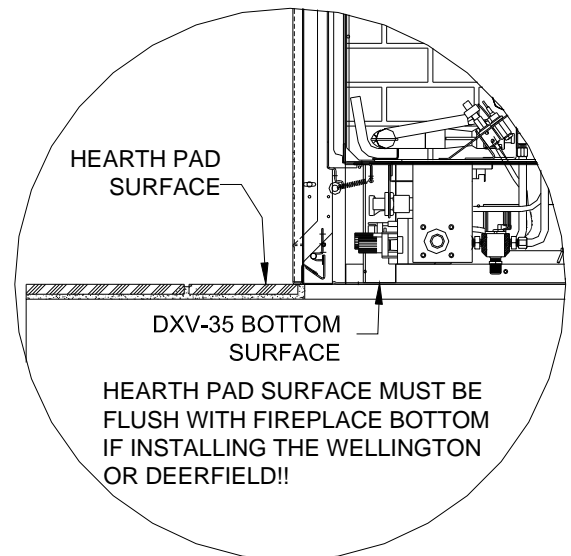

" Label Representation"

DXV35 TIMBER FIRE



Also for use in mobile (manufactured) homes after first sale of home.
 Tested to ANSI Z21.88 (2002) - CSA 2.33 (2002)

WARNING: Improper installation, adjustment, alteration, service or maintenance can cause property damage, personal injury, or loss of life. Refer to the owner's information manual provided with this appliance. Installation and service must be performed by a qualified installer, service agency or the gas supplier. Use only glass assemblies certified for use with this appliance. Do not operate with glass panel(s) removed, cracked, or broken.

NOT FOR USE WITH SOLID FUEL

	NATURAL GAS	PROPANE GAS
Input Rating (Btu/hr) 0-610 m	33,000	21,000
Orifice (DMS) 0-610 m	32	50
Manifold Pressure (in w.c.)	3.5	10.0
Manifold Pressure, low (in w.c.)	1.7	3.6
Minimum Inlet Pressure (in w.c.)	5.0	11.0

This appliance is equipped for installation at 0-610 meters. This appliance must be installed in accordance with local codes if any; If not, follow ANSI Z223.1. Mobile (Mfg.) home installations must adhere to Title 24 CFR, Part 3280.

MINIMUM CLEARANCES FROM COMBUSTIBLE CONSTRUCTION			
Unit to floor	0 in.	Unit to enclosure sidewalls	0.5 in.
Unit to enclosure sidewall	0.5 in.	Unit top to ceiling	18 in.
Vent to enclosed	1 in.	Wall Pass-Through to framing	1 in.
Vent to adjacent sidewall	10 in.	Mantle above discharge air opening	14 in.

CAUTION: Hot while in operation. Do not touch. Keep children, clothing, furniture, and flammable liquids or vapors away.

Electrical Rating (Courant nominal): 120 volts 60 Hz Less than 1 Ampere

JOHNSON GAS APPLIANCE
 CEDAR RAPIDS, IOWA
 DO NOT REMOVE OR COVER THIS LABEL

 WH#

MENDOTA WARRANTY QUALIFICATION & SERVICE REFERENCE FORM

As a part of Mendota's on-going program of customer satisfaction, this Form verifies proper installation and operation. It is important as a reference for future service. It insures long life and trouble-free operation of Mendota fireplaces & stoves and qualifies the owner for Mendota's lifetime limited warranty. Owner should sign Form when completed and mail a copy along with Warranty Registration to Mendota. Optionally, please register at our website at: WWW.JOHNSONGAS.COM/MENDOTA-REGISTRATION.ASP

HOME OWNER: _____ DEALER: _____
 ADDRESS: _____ ADDRESS: _____
 CITY/STATE/ZIP: _____ CITY/STATE/ZIP: _____
 SIGNATURE: _____ PHONE: _____
 MODEL #: DXV-35 _____ SERIAL #: _____ DATE
 INSTALLED: _____

Mendota direct vent fireplaces are sophisticated, hi-tech gas appliances. All installation and operating instructions must be carefully followed. The DXV fireplace must be installed and serviced by a qualified Mendota approved service person.

REF: MENDOTA DXV INSTALLATION MANUAL

- APPROVED VENT PIPES AND VENT CAP INSTALLED - Per Manual.
 Vent pipes must be fully twist-locked and leak proof.
 Check minimum and maximum vertical / horizontal and vent runs.
 1000° sealant must be used on inner joints at adjustable pipe sections.
- CHECK FOR PROPER CLEARANCES TO COMBUSTIBLES & VENT LOCATIONS - Per Manual
- INSTALL PROPER SIZE GAS LINES - CHECK FOR GAS LEAKS - Per Manual
- CHECK FOR CORRECT GAS PRESSURE AT MANIFOLD - Per Manual
 - a. 3.5 Inches Water Column Maximum - Nat. Gas
 - b. 10.5 Inches Water Column Maximum - L.P. Gas
- TAKE COMBUSTION SYSTEM MILLIVOLT READINGS [See Manual pg.. 45
 - a. Pilot only - [Minimum Millivolts 325] Reading: _____
 - b. Main burner operating - [Minimum Millivolts 100] Reading: _____
- CYCLE BURNERS ON/OFF FOR PROMPT IGNITION - Per "LIGHTING INSTRUCTIONS"
 Burner must light IMMEDIATELY - Flame must travel promptly around "curve" & light burner.
- INSTALL LOGS AND ADJUST FLAME - Per Manual
 Proper pilot flame impingement on thermopile & burner - Air shutter opening: 1/8" - 1/4" Nat. Gas - 1/2" LP
 Check that flame is "stable" and is not "lifting" off burner
- BRIEF OWNER ON OPERATION AND MAINTENANCE OF UNIT
 - Light Pilot
 - Operate Burner
 - Explain blower "delay" operation

WARRANTY REGISTRATION

Your Name _____

Address _____

City _____ State _____ Zip _____

Dealer (Place of Purchase) _____

City _____ State _____ Zip _____

Date of Purchase _____ Serial Number _____

Purchaser's Signature _____

MENDOTA DXV-35 DIRECT VENT FIREPLACE

CUT OUT PAGE AND MAIL TO: JOHNSON GAS APPLIANCE CO., 520 E AVE. N.W., CEDAR RAPIDS, IOWA 52405
 OPTIONALLY, PLEASE REGISTER AT OUR WEBSITE AT: WWW.JOHNSONGAS.COM/MENDOTA-REGISTRATION.ASP

TAPE SHUT

**POSTAGE
NEEDED**

**JOHNSON GAS APPLIANCE COMPANY
520 E AVENUE N.W.
CEDAR RAPIDS, IA 52405**

MENDOTA EXTENDED LIFETIME PROTECTION AND LIMITED WARRANTY

MENDOTA DXV-35 DIRECT VENT FIREPLACE

Mendota Division of Johnson Gas Appliance Company, 520 E Avenue N.W. Cedar Rapids, Iowa 52405, extends this Extended Lifetime Protection and Limited Warranty to the original purchaser of a Mendota DXV Fireplace, Serial Number, which is limited and used under normal home conditions.

STANDARD WARRANTY:

JOHNSON GAS APPLIANCE CO., MENDOTA DIVISION, WARRANTS THAT YOUR NEW MENDOTA DXV FIREPLACE IS FREE FROM MANUFACTURING AND MATERIAL DEFECTS FOR A PERIOD OF ONE YEAR FROM THE DATE OF INSTALLATION, SUBJECT TO THE FOLLOWING CONDITIONS AND LIMITATIONS:

EXTENDED LIFETIME WARRANTY:

THE HEAT EXCHANGER, BURNER TUBE COMBUSTION CHAMBER AND OUTER SHEILD OF THE MENDOTA DXV FIREPLACE ARE WARRANTED FOR THE LIFETIME OF THE ORIGINAL OWNER, SUBJECT TO PROOF OF PURCHASE AND THE FOLLOWING CONDITIONS AND LIMITATIONS:

- 1) This new Mendota Fireplace must be installed & serviced by a competent, authorized service contractor. It must be installed and operated at all times in accordance with the installation and operating instructions furnished with the Fireplace. All adjustments to logs, coals or burner must be made by an authorized Mendota person. Any alteration, willful abuse, accident or misuse of the product shall nullify this warranty. This warranty does not cover glass or log breakage.

This limited warranty does not cover the cost of service calls, the cost of labor to remove or install parts covered by this limited warranty, freight or other transportation expenses, which may be incurred in connection with obtaining performances under this limited warranty. The remedy for damages as the result of any defects in this product which have been warranted herein is limited to replacement parts and does not include any incidental, indirect or consequential damages or expenses sustained in connection with the product, including damages to property, except as provided by law.

- 2) This warranty is non-transferable and is made to the original retail purchaser, provided the purchase was made through an authorized Mendota dealer.

Mendota is not responsible for any damage to or malfunction of the Fireplace unless caused by a defect in material or workmanship from normal home use. Damage caused by abuse, improper installation, improper servicing, and installation by unqualified personnel or breach of conditions of this

limited warranty will excuse Mendota from performance of any part of this limited warranty. Mendota has the right to investigate and inspect the exact, original Fireplace and entire installation (without any alterations or tampering) in the event a claim is made to determine whether the claimed damage or malfunction was caused by abuse, improper installation or other cause outside this warranty. Mendota is not responsible for any repairs or material purchases that have not received prior written approval from Mendota.

NOTE: Minor warping of certain parts or discoloration is normal and is not a defect covered by this warranty. Major warping of parts can be caused by over-firing of your Mendota Fireplace. Over-firing above rated nameplate specification is as contrary to the manufacturer's instructions and may void this warranty.

This warranty may not be extended by our representatives or any third party in any manner. The company neither assumes, nor authorizes any third party to assume, on its behalf, any other liabilities with respect to the sale of this Mendota product.

- 3) Mendota may at its discretion, fully discharge all obligations of this warranty by refunding the wholesale price of the defective part(s).
- 4) All other warranties - expressed or implied - with respect to the product, its components and accessories, or any obligation/liabilities on the part of the company are hereby expressly excluded. Products made by other manufacturers, sold with the Fireplace or thereafter, are not covered by this limited warranty. The use of unauthorized components will make this warranty null and void.

This warranty shall be effective only if the original purchaser of the Mendota appliance is registered with Mendota Division within thirty (30) days of the date of purchase. Such registration or the failure to register shall not be deemed to create any obligation or liability by the manufacturer and this warranty with its conditions and limitations shall be the only procedure for obtaining any rights against the manufacturer and expresses the sole obligation and responsibilities of the manufacturer which are offered to the original purchaser and accepted upon purchase of the appliance.

Mendota Division, reserves the right to make changes at any time without notice, in design, material, specifications, prices and the right to discontinue styles and products.

Some states do not allow the exclusion of limitation of incidental or consequential damages or limitations on how long an implied warranty lasts, so the above limitation or exclusion may not apply to you. This warranty gives you specific legal rights and you may also have other rights which vary from state to state.

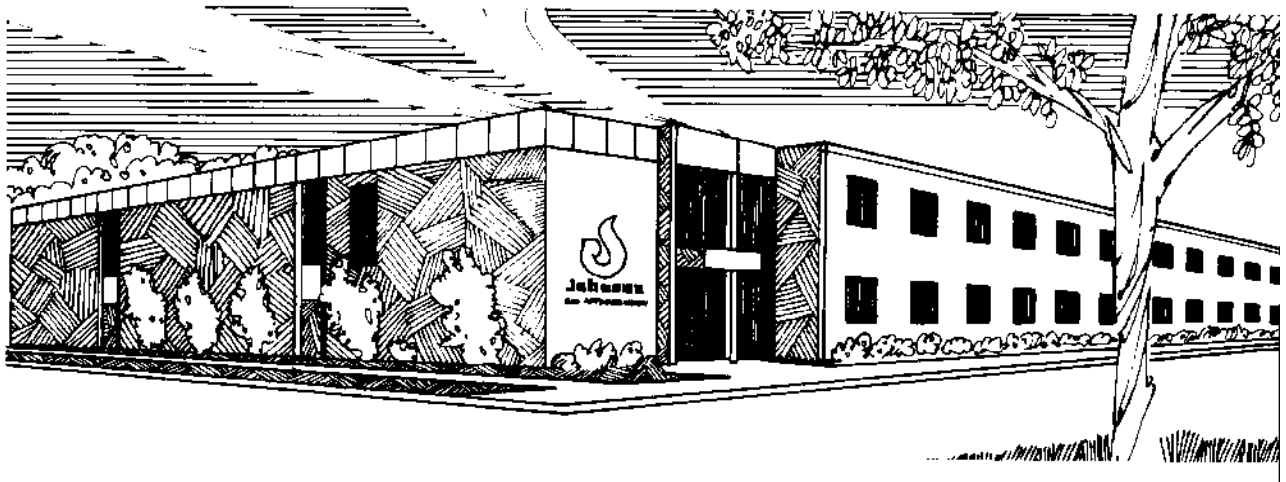

Johnson Gas Appliance Company
520 E Avenue N.W. - Cedar Rapids, IA 52405
Mendota Hearth Division

WEBPAGE: www.johnsongas.com or www.mendotahearth.com