

MENDOTA

NORTH AMERICA'S LUXURY FIREPLACE

MODEL NO. FV33i - 0716

FullView Direct Vent Gas Fireplace Insert Heater Installation & Operating Instructions

WARNING: If the information in these instructions are not followed exactly, a fire or explosion may result causing property damage, personal injury or loss of life.

- Do not store or use gasoline or other flammable vapors and liquids in the vicinity of this or any other appliance.
- **WHAT TO DO IF YOU SMELL GAS**
 - Do not try to light any appliance.
 - Do not touch any electrical switch; do not use any phone in your building.
 - Immediately call your gas supplier from a neighbor's phone. Follow the gas supplier's instructions.
 - If you cannot reach your gas supplier, call the fire department.
- Installation and service must be performed by a qualified installer, service agency or the gas supplier.

This appliance may be installed in an aftermarket permanently located, manufactured home (USA only) or mobile home, where not prohibited by local codes.

This appliance is only for use with the type of gas indicated on the rating plate. This appliance is not convertible for use with other gassed, unless a certified kit is used.

A barrier designed to reduce the risk of burns from the hot viewing glass is provided with this appliance and shall be installed.

WARNING



**HOT GLASS WILL
CAUSE BURNS.
DO NOT TOUCH GLASS
UNTIL COOLED.
NEVER ALLOW CHILDREN
TO TOUCH GLASS.**

Gas Fireplaces

TABLE OF CONTENTS

LISTING LABEL INFORMATION	1
Listing Label Location	1
SAFETY AND WARNING INFORMATION	2
Congratulations.....	2
Building Permit and Inspection Approval Requirements	2
Safety Warnings.....	2
Specific Requirements for the Commonwealth of Massachusetts.....	5
GENERAL INFORMATION	6
Safety and Structural Concerns.....	6
Heating Performance	6
Electrical Requirements	6
Manual Gas Shutoff Valve Installation Requirement.....	6
INITIAL STARTUP INFORMATION AND ADVICE	7
Initial Burn Cycle	7
Paint Curing Cycle	7
Blower Break-in Period	7
Paint Types Approved for Use	7
Sealant Types Approved For Use	7
Additional Application Cautions	7
SPECIFICATIONS	8
General Specifications	8
Overall Dimensions	9
Required Clearances	10
MANTEL INFORMATION	11
HEARTH PROTECTION PAD REQUIREMENTS	12
VENTING REQUIREMENTS	14
General Venting Requirements	14
Venting Installation Instructions.....	15
Vent Damper Setting.....	17
ELECTRICAL REQUIREMENTS	18
Planning for AC 120 VAC Connection	18
Backup DC Power Connection	19
Operating During Power Outages	19
GAS SUPPLY REQUIREMENTS	20
Gas Supply Line Sizing	20
Gas Pressure Checking	21
Gas Input Rate Verification	22
Natural Gas Input Rate Verification	22
LP Gas Input Rate Verification	22
High Altitude De-Rating	22

CONVERTING INSERT FOR LP GAS	23
Orifice Size Requirement	23
Procedure to Convert Insert for LP Gas	23
LP Pressure Regulator Conversion Instructions.....	27
Checking Burner(s) Ignition Characteristics.....	28
Attaching LPG Conversion Labels	28
LP Gas Pressure Requirements.....	29
LP Gas Proper Input Rates	29
Leak Testing Requirements	29
Pilot Flame and Main Burner Relationship Verification.....	29
Pilot Flame Length Adjustment.....	29
LOG SET INSTALLATION	30
INSTALLATION CHECK OFF LIST	41
LIGHTING CHECK OFF LIST	41
USING THE REMOTE CONTROL	42
Remote Control Transmitter Functions.....	42
Setting Pilot to IPI versus CPI Mode.....	42
Remote Control Transmitter Operating Instructions.....	43
To Turn ON the Appliance	43
To Turn OFF the Appliance.....	43
Remote Functions	43
Synchronizing the Receiver and Transmitter	44
FIRST TIME LIGHTING INSTRUCTIONS	45
Safety Information.....	45
Operating Instructions.....	45
To Turn OFF Gas to Appliance	45
FLAME APPEARANCE ADJUSTMENT	46
TROUBLE-SHOOTING	47
Common Trouble-Shooting Information.....	47
Over Firing or Under Firing of Burner	47
Pilot Outage and Re-Lighting	47
Cleaning Viewing Glass.....	47
Trouble-Shooting Mendota Gas Inserts.....	47
MAINTENANCE	48
Required Annual Maintenance	48
Periodic Inspections Required.....	48
Burner Flames General Heights Reference Diagram	48
WIRING DIAGRAM	49
BLOWERS	50
Blower Operation	50
GLASS FRAME REMOVAL	51
Removing the Glass Frame.....	51
Installing the Glass Frame.....	51

SERVICE PARTS **52**
Valve Assembly 52
Burner Parts..... 53
Blower Parts..... 53
Glass Frame Assembly Repair and Replacement 54

MENDOTA WARRANTY & SERVICE FORM..... **55**

MENDOTA LIFETIME WARRANTY **57**
Standard Warranty 57
Extended Lifetime Warranty 57

LISTING LABEL INFORMATION

When contacting your dealer for any cleaning service or warranty service, always provide the Model Number, Serial Number and Manufactured Date. This information will expedite the warranty verification process.



WN 20170

LISTED DIRECT VENT GAS FIREPLACE HEATER
(POELE AU GAZ HOMOLOGUÉ, A AERATION DIRECTE)
NOT FOR USE WITH SOLID FUEL
(NE DOIT PASÉ UTILISÉ AVEC UN COMBUSTIBLE SOLIDE)
MANUFACTURED BY (FABRIQUÉ PAR): M-T-M CORP., PEOSTA IOWA
FOR JOHNSON GAS APPLIANCE CO. CEDAR RAPIDS, IOWA
CERTIFIED FOR CANADA HOMOLOGUE POUR LE CANADA
TESTED TO (TESTÉ AUX NORMES)
ANSI Z21.88-2014 * CSA 2.33-2014



WARNING

HOT GLASS WILL CAUSE BURNS.
DO NOT TOUCH GLASS UNTIL COOLED.
NEVER ALLOW CHILDREN TO TOUCH GLASS.

WARNING: IMPROPER INSTALLATION, ADJUSTMENT, ALTERATION, SERVICE OR MAINTENANCE CAN CAUSE PROPERTY DAMAGE, PERSONAL INJURY, OR LOSS OF LIFE. REFER TO THE OWNER'S INFORMATION MANUAL PROVIDED WITH THIS APPLIANCE. INSTALLATION AND SERVICE MUST BE PERFORMED BY A QUALIFIED INSTALLER. DO NOT OPERATE WITH GLASS DOOR REMOVED, CRACKED, OR BROKEN. THIS VENTED GAS FIREPLACE HEATER IS NOT FOR USE WITH AIR FILTERS. REGISTER KIT MAY BE USED.

MISE EN GARDE: INSTALLATION, RÉGLAGE, MODIFICATION, ENTRETIEN OU DÉPANNAGE NON APPROPRIÉS POURRONT CAUSER DES BLESSURES OU DES DOMMAGES MATÉRIELS. RÉFÉREZ-VOUS AU MANUEL DU PROPRIÉTAIRE FOURNI AVEC CET APPAREIL. POUR ASSISTANCE OU RENSEIGNEMENTS COMPLÉMENTAIRES, VEUILLEZ CONSULTER UN INSTALLATEUR EXPÉRIMENTÉ, UNE AGENCE DÉ DÉPANNAGE/ENTRETIEN OU COTRE COMPAGNIE GAZIERE, POUR UTILISATION AVEC LES PORTES EN VERRE CERTIFIÉE L'APPAREIL SEULEMENT. NE PAS OPÉRER AVEC LE VERRIERE ENLEVER, CRAQUELURE, BRISE.

	<input type="checkbox"/> NATURAL GAS (GAZ NATUREL)	<input type="checkbox"/> LP GAS (GAS DE PÉTROLE LIQUÉFIÉ (GPL))
INPUT RATING (BTR/HR) 0-610m (ENTRÉE NOMINALE)	31,000	31,000
MIN. INPUT RATING (BTU/HR) 0-2000ft (0-610m) (MINIMALE ENTRÉE NOMINALE)	10,000	13,000
ORIFICE 0-2000ft (0-610m) (FRONT/REAR)	#45 / #49	3/64" / 3/64"
ORIFICE 610-1370m (FRONT/REAR)	#46 / #49	#56 / 3/64"
INPUT RATING (BTU/HR) 2000-4500ft (610-1370m) (ENTRÉE NOMINALE)	30,000	30,000
MAXIMUM OUTPUT (BTU/HR) (SORTIE MAXIMALE)	21,700	21,700
MANIFOLD PRESSURE (in. w.c./kPa) (PRESSION AU COLLECTEUR)	3.5	10.0
MANIFOLD PRESSURE, LOW (in. w.c./kPa) (PRESSION D'ENTRÉE MINIMALE)	1.7	6.3
MINIMUM INLET PRESSURE (in. w.c./kPa) (PRESSION D'ENTRÉE MINIMALE)	5.0	11.0

THIS APPLIANCE IS ONLY FOR USE WITH THE TYPE OF GAS INDICATED ON THE RATING PLATE AND MAY BE INSTALLED IN AN AFTERMARKET, PERMANENTLY LOCATED MANUFACTURED (MOBILE) HOME WHERE NOT PROHIBITED BY LOCAL CODES. SEE OWNER'S MANUAL FOR DETAILS. THIS APPLIANCE IS SUPPLIED WITH A CONVERSION KIT. THIS VENTED GAS FIREPLACE IS NOT FOR USE WITH A FILTER. NOT FOR USE WITH AFTERMARKET GLASS DOORS---CET APPAREIL SERA INSTALLÉ CONFORMÉMENT AVEC LES CODES LOCAUX, LE CAS ÉCHÉANT. SI AUCUN CODE N'EXISTÉ, SUIVEZ LA NORME ANSI Z223.1 OULA NORME CAN/CGA (ACNOR)-B149.

MINIMUM CLEARANCES TO COMBUSTIBLE CONSTRUCTION

UNIT TO SIDEWALL	16 in. (407 mm)	UNIT TOP TO 8" MANTLE	12 in. (305 mm)
------------------	-----------------	-----------------------	-----------------

CAUTION: HOT WHILE IN OPERATION. DO NOT TOUCH. KEEP CHILDREN, CLOTHING, FURNITURE, AND FLAMMABLE LIQUIDS OR VAPORS AWAY.
ATTENTION: L'APPAREIL EST CHAUD LORSQU'IL FONCTIONNE. NE PASS TOUCHER L'APPAREIL. SURVEILLER LES ENFANTS. GARDER LES VÊTEMENTS, LES MEUBLES, L'ESSENCE OU AUTRES LIQUIDES À VAPEUR INFLAMMABLES LOIN DE L'APPAREIL.

ELECTRICAL RATING (COURANT NOMINAL): 120 VOLTS 60 HERTZ LESS THAN 1.5 AMPERES

DO NOT REMOVE OR COVER THIS LABEL
VEUILLEZ A NE JAMES ENLEVER NI DISSIMULER CETTE ÉTIQUETTE

MFG. DATE:

MODEL: FV33i

SERIAL NO. WH-FV33i -

65-01-001362

Listing Label Location

The listing label is located in the air gap on the left side of the insert between the glass frame and outer edge of the insert. It is connected with a chain and can be pulled out to be viewed.

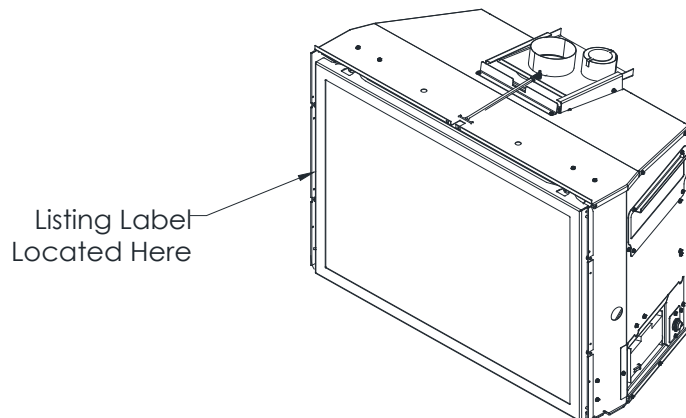

SAFETY AND WARNING INFORMATION

Congratulations

You are the owner of a world-class heat producing gas direct vent sealed combustion fireplace.

This elegant, highly efficient Fireplace will be a constant source of comfort and fascination. It will be the focal point of beauty and interest in your home.

The Mendota Gas Fireplace is a true heating appliance incorporating the traditional aesthetics of fireplace fire viewing with the controllability and fuel efficiency of a home gas furnace. Of particular interest is the low fuel consumption and brilliant fire viewing afforded by the realistic wood fire-like combustion system.

Carefully read the following instructions prior to actual installation. Proper Mendota Gas Fireplace installation and operation will give you years of safe, trouble free comfort and enjoyment.

If you have any questions regarding installation or operation of your Mendota Fireplace please contact your local dealer.

Building Permit and Installation Inspection Approval Requirements

All installations of Mendota Fireplaces and Inserts must comply with all the requirements stated in this Installation and Operating Instructions Manual. The Dealer and/or installer must also obtain all required Building Permits and Inspection Approval from the local building inspection department or the local body having jurisdiction. In order to validate warranty coverage, Mendota may require facsimile copies of the Building Permit and Inspection Approval forms. Failure to provide adequate proof that the installation conforms to all local requirements and the requirements stated in the Installation and Operating Instructions Manual will void all applicable warranty.

INSTALLER: THESE INSTRUCTIONS ARE TO REMAIN WITH HOMEOWNER.

HIGH ALTITUDE INSTALLATION INFORMATION: Prior to installing at altitudes higher than 7500, understand the need for gas input de-rating. Contact Mendota Technical Service for support.

Safety Warnings

⚠ WARNING

Warning: This product contains lead, a chemical known to the State of California to cause birth defects or other reproductive harm.

Wash your hands after handling this product.

⚠ WARNING

The exhaust from this product contains chemicals known to the State of California to cause cancer, birth defects or other reproductive harm.

⚠ WARNING

This product contains one or more chemicals known to the State of California to cause cancer and birth defects or other reproductive harm.

FOR YOUR SAFETY

A qualified installer, service agency, or the gas supplier must perform installation and service. Do not store or use gasoline or other flammable vapors and liquids in the vicinity of this or any other appliance.

WARNING

Do not operate this appliance with the glass removed, cracked or broken. A licensed or qualified person should do replacement of glass.

AVERTISSEMENT. Ne pas utiliser l'appareil si le panneau frontal en verre n'est pas en place, est craqué ou brisé. Confiez le remplacement du panneau à un technicien agréé.

WARNING

Mendota gas fireplaces are heat producing appliances. Do not burn wood, paper or other materials in this fireplace. This fireplace is designed as a supplement heat source. It is advisable to have an alternative primary heat supply.

In the Commonwealth of Massachusetts:

- Installation must be performed by a licensed plumber or gas fitter;
- A CO detector shall be installed in the room where the appliance is installed.

WARNING: Improper installation, adjustment, alteration, service or maintenance can cause injury or property damage. Refer to this manual. For assistance or additional information consult a qualified installer, service agency or the gas supplier.

This appliance may be installed in an aftermarket permanently located, manufactured (mobile) home (USA Only), where not prohibited by local codes.

This appliance is only for use with the type(s) of gas indicated on the rating plate. This appliance is not convertible for use with other gases, unless a certified kit is used.

Cet appareil peut être installé dans un maison préfabriquée (mobile) déjà installée à demeure si les règlements locaux le permettent.

Cet appareil doit être utilisé uniquement avec les types de gas indiqués sur la plaque signalétique. Ne pas l'utiliser avec d'autres gas sauf si un kit de conversion certifié est installé.

The installation must conform with local codes or, in the absence of local codes, to the current National Fuel Gas Code, ANSI Z223.1 (NFPA 54) or CAN/CGA B149.1 Installation Code.

Installer l'appareil selon les codes ou règlements locaux, ou, en l'absence de tels règlements, selon les Codes d'installation CAN/CGA-B149.

READ and UNDERSTAND all instructions carefully before starting the appliance. **FAILURE TO FOLLOW** these instructions may result in a possible fire hazard and will void the warranty.

Any safety screen or guard removed for servicing must be replaced before operating this appliance.

Tout écran ou protecteur retiré pour permettre l'entretien de l'appareil doit être remis en place avant de mettre l'appareil en marche.

THIS UNIT IS NOT FOR USE WITH SOLID FUEL.

Installation and repair should be **PERFORMED** by a qualified service person. The appliance and venting system should be **INSPECTED** before initial use and at least annually by a professional service person. More frequent cleaning may be required due to excessive lint from carpeting, bedding, material, etc. It is **IMPERATIVE** that the unit's control compartment, burners, and circulating air passageways **ARE KEPT CLEAN** to provide for adequate combustion and ventilation air.

Always KEEP the appliance clear and free from combustible materials, gasoline, and other flammable vapors and liquids.

NEVER OBSTRUCT the flow of combustion and ventilation air. Keep the front of the appliance **CLEAR** of all obstacles and materials for servicing and proper operation.

Due to high temperature, the appliance should be **LOCATED** out of traffic areas and away from furniture and draperies. En raison des températures élevées, l'appareil devrait être installé dans un endroit où il y a peu de circulation et loin du mobilier et des tentures.

Clothing or flammable material **SHOULD NOT BE PLACED** on or near the appliance.

On ne devrait pas placer de vêtements ni d'autres matières inflammables sur l'appareil ni à proximité.

Children and adults should be **ALERTED** to the hazards of high surface temperature and should **STAY AWAY** to avoid burns or clothing ignition.

Les enfants et les adultes devraient être informés des dangers que posent les températures de surface élevées et se tenir à distance afin d'éviter des brûlures ou que leurs vêtements ne s'enflamment.

Young children should be **CAREFULLY SUPERVISED** when they are in the same room as the appliance. Toddlers, young children and others may be susceptible to accidental contact burns. A physical barrier is recommended if there are at risk individuals in the house. To restrict access to a fireplace or stove, install an adjustable safety gate to keep toddlers, young children and other at risk individuals out of the room and away from hot surfaces.

"Les jeunes enfants devraient être surveillés étroitement lorsqu'ils se trouvent dans la même pièce que l'appareil. Les tout petits, les jeunes enfants ou les adultes peuvent subir des brûlures s'ils viennent en contact avec la surface chaude. Il est recommandé d'installer une barrière physique si des personnes à risques habitent la maison. Pour empêcher l'accès à un foyer ou à un poêle, installez une barrière de sécurité; cette mesure empêchera les tout petits, les jeunes enfants et toute autre personne à risque d'avoir accès à la pièce et aux surfaces chaudes.

These units **MUST** use one of the vent systems described in the Flue Venting section of this manual.

This gas fireplace and vent assembly **MUST** be vented directly to the outside and **MUST NEVER** be attached to a chimney serving a separate solid fuel-burning appliance. Each gas appliance **MUST USE** a separate vent system. Common vent systems are **PROHIBITED**.

The vent system assembly for this fireplace must be periodically examined by a qualified service agency.

If the vent-air intake system is disassembled for any reason, reinstall per the instructions provided for the initial installation.

INSPECT the external vent cap on regular basis to make sure that no debris is interfering with the airflow. The flow of combustion and ventilation air not to be obstructed

DO NOT abuse the glass door by striking the glass, slamming the door shut, etc.

Use only authorized parts and materials obtained from Johnson Gas Appliance Company when replacing defective or damaged glass.

DO NOT USE abrasive cleaners on the glass door assembly. **DO NOT ATTEMPT** to clean the glass door when it is hot.

Turn off the gas before servicing this appliance. It is recommended that a qualified service technician perform an appliance check-up at the beginning of each heating season.

DO NOT place furniture or any other combustible household objects within 36 inches of the fireplace front.

This vented gas fireplace heater is not for use with air filters".
Foyer au gaz à évacuation.- Ne pas utiliser avec du combustible solide.

Keep burner and control compartment clean. See installation and operating instructions accompanying appliance." S'assurer que le brûleur et le compartiment des commandes sont propres. Voir les instructions d'installation et d'utilisation qui accompagnent l'appareil.

WARNING: Improper installation, adjustment, alteration, service or maintenance can cause injury or property damage. Refer to the owner's information manual provided with this appliance. For assistance or additional information consult a qualified installer, service agency or the gas supplier.

L'AVERTISSEMENT: L'installation inconvenante, ajustement, modification, service ou entretien peut causer les dommages de propriété ou blessure. Référer au manuel d'information de propriétaire fourni cet appareil. Pour l'assistance ou information supplémentaire consulte un qualifiée installateur, agence de service ou le fournisseur de gaz.

DO NOT USE this appliance if any part has been under water. Immediately **CALL** a qualified service technician to inspect the appliance and to replace any part of the control system and any gas control, which has been underwater.

This appliance is for use with only doors certified by Mendota. Do not use any fronts or doors with this appliance unless they are certified by Mendota and installed by a certified installer.

Specific Requirements for the Common Wealth of Massachusetts

The information in this section applies to all installations performed in the Common Wealth of Massachusetts only.

- a) For all side wall horizontally vented gas fueled equipment installed in every dwelling, building or structure used in whole or in part for residential purposes and where the side wall exhaust vent termination is less than seven (7) feet above grade, the following requirements shall be satisfied:
1. If there is no carbon monoxide detector with an alarm already installed in compliance with the most current edition of NFPA 720, NFPA 70 and the Massachusetts State Building code in the residential unit served by the side wall horizontally vented gas fueled equipment, a battery operated carbon monoxide detector with an alarm shall be installed in compliance with the most current edition of NFPA 720, NFPA 70 and the Massachusetts State Building Code.
 2. In addition to the above requirements, if there is not one already present, a carbon monoxide detector with an alarm and a battery backup shall be installed and located in accordance with the installation requirements supplied with the detector on the floor level where the gas equipment is installed. The carbon monoxide detector with an alarm shall comply with 527 CMR, ANSI/UL 2034 Standards or CSA 6.19 and the most current edition of NFPA 720. In the event that the requirements of this subdivision cannot be met at the time of the completion of the installation of the equipment, the installer shall have a period of thirty (30) days to comply with this requirement; provided, however, that during said thirty (30) day period, a battery operated carbon monoxide detector with an alarm shall be installed in compliance with the most current edition of NFPA 720, NFPA 70 and the Massachusetts State Building Code. In the event that the side wall horizontally vented gas fueled equipment is installed in a crawl space or an attic, the carbon monoxide detector may be installed on the next adjacent habitable floor level. Such detector may be a battery operated carbon monoxide detector with an alarm and shall be installed in compliance with the most current edition of NFPA 720, NFPA 70 and the Massachusetts State Building Code.
 3. A metal or plastic identification plate shall be permanently mounted to the exterior of the building at a minimum height of eight (8) feet above grade directly in line with the exhaust vent terminal for the horizontally vented gas fueled heating appliance or equipment. The sign shall read, in print size no less than one-half (1/2) inch in size, "GAS VENT DIRECTLY BELOW, KEEP CLEAR OF ALL OBSTRUCTIONS"
 4. A final inspection by the state or local gas inspector of the side wall horizontally vented equipment shall not be performed until proof is provided that the state or local electrical inspector having jurisdiction has granted a permit for installation of carbon monoxide detectors and alarms as required above.
- (b) EXEMPTIONS: The following equipment is exempt from 248 CMR 5.08(2) (a) 1 through 4:
1. The equipment listed in Chapter 10 entitled "Equipment Not Required To Be Vented" in the most current edition of NFPA 54 as adopted by the Board; and
 2. Product Approved side wall horizontally vented gas fueled equipment installed in a room or structure separate from the dwelling, building or structure used in whole or in part for residential purposes.
- (c) When the manufacturer of Product Approved side wall horizontally vented gas equipment provides a venting system design or venting system components with the equipment, the instructions for installation of the equipment and the venting system shall include:
1. A complete parts list for the venting system design or venting system; and
 2. Detailed instructions for the installation of the venting system design or the venting system components.
- (d) When the manufacturer of a Product Approved side wall horizontally vented gas fueled equipment does not provide the parts for venting the flue gases, but identifies "special venting systems", the following shall be satisfied:
1. The referenced "special venting system" instructions shall be included with the appliance or equipment installation instructions; and
 2. The "special venting systems" shall be Product Approved by the Board, and the instructions for that system shall include a parts list and detailed installation instructions.
- (e) A copy of all installation instructions for all Product Approved side wall horizontally vented gas fueled equipment, all venting instructions, all parts lists for venting instructions, and/or all venting design instructions shall remain with the appliance or equipment at the completion of the installation.

GENERAL INFORMATION

Your Mendota Gas Fireplace Insert has a state-of-the-art direct vent, sealed combustion system. This advanced, highly efficient system brings in outside air for combustion, has a separate exhaust vent and efficiently heats and re-circulates room air. The Mendota system maintains high air quality, maximizes efficiency and assures proper operation.

Safety and Structural Concerns

This Mendota Fireplace Insert shall only be installed in an existing Masonry Wood Burning Fireplace or a Factory Built Wood Burning Fireplace.

A non-combustible hearth protector is required and must extend a minimum of 16" in front of the fireplace when this insert is installed at floor level. For every 1" that the insert is raised off the floor the hearth protector can be reduced by 2".

Any existing or new combustible mantel must fall within the Mantel Profile Chart located in this manual. If an existing mantel does not conform to the chart relocate it or install a 20 gage metal shield under the mantel. The shield must extend the full length and width of the mantel. The shield must be placed 1" below the mantel to provide an active air space.

Use only Mendota approved Vent Systems and Vent Caps.
Only Fronts and Doors certified with this appliance by Mendota shall be used.

Heating Performance

This Mendota Fireplace Insert is a true, high efficiency gas heater. The Mendota Insert will usually heat a large area of your home if situated to maximize heat circulation. The Mendota Insert is designed as a supplemental heat source. It should not be used as a whole house heating system. Supplemental air movement considerations for maximizing heat circulation are: through-the-wall grills, floor grills, ceiling fans, or the continuous operation of central heating and cooling blowers.

Electrical Requirements

Electronic Ignition System, Dual Blowers and an Accent Light system are included in this Mendota Direct Vent Fireplace. These devices require constant electrical power except during power outages. A 115-volt electrical service must be supplied at the fireplace location at the time of installation, on the right side of this fireplace. It must be electrically grounded in accordance with local codes, or in their absence, with the current edition of the National Electric Code ANSI/NFPA 70. Use of a wall switch control in the power supplied to this fireplace is NOT allowed.

Thermostatic function is included in the remote control transmitter. Therefore, no thermostat wire is required.

Manual Gas Shutoff Valve Installation Requirement

A manual Shutoff Ball valve is factory installed in the appliance and is accessible through the air gap on the left of the glass frame. Use the glass latch tool to operate the Shutoff Ball valve. If local building codes require, obtain an external Wall Mounted Manual Gas Shutoff Valve approved per local gas plumbing codes and install per local gas plumbing codes in the specified location.

INITIAL STARTUP INFORMATION AND ADVICE

CAUTION: Before you ignite the pilot or burners, perform the following inspections and verifications:

Check glass gasket seal. Visually inspect glass gasket, especially at the corners of the glass piece. Gasket that bulges at corners can cause improper seals between the bulges which can cause exhaust leaks and lead to smell concerns.

If facing materials are freshly painted or freshly polished (in cases of marble or granite), make certain that the convection blower is running at level 2 or level 3 during the first 1-1/2 hours of initial burn. After the 1-1/2 hours, turn off the convection blower and proceed with the paint curing cycle.

Initial Burn Cycle: During the first burn cycle (approximately for 3 hours), it is normal for this appliance to emit visible smoke and some odor. The smoke generated is a mixture of paint curing, lubricating oils burning off, glass gasket adhesive curing and ceramic sealant gaskets curing. The smoke generated can trigger smoke and fire alarms. It is recommended to open all door and windows during initial cure cycle.

WARNING FIRE RISK- ODOR RISK

- Install appliance only in an existing Masonry Wood Burning Fireplace or a Factory Built ZC Wood Burning Fireplace.
- An R-1 Rated Hearth Protection Pad [1-1/2" Thick Maximum] is required unless this fireplace is elevated at least 6" above floor level of the room. For every 1" this fireplace is elevated, you may reduce the hearth pad depth by 2". If this fireplace is elevated 6" or higher no hearth protection pad is required.
- Locate and install appliance to all clearance specifications in manual.
- Verify glass gasket seal before firing unit the first time. Verify proper latching of glass frame onto unit body.

Paint Curing Cycle: It is recommended that you run this Fireplace on maximum flame height with the Convection Blowers turned on at level 2 or level 3 for the first 1-1/2 hours. After the first 1-1/2 hours, turn OFF the Convection blowers and proceed burning on high fire for 1 cycle of 2 hours ON and 2 hours OFF to cure the paint and expel any burn off odors. Expect some visible smoke and smell during the curing cycle. Open all door and windows during initial cure cycle.

Blower Break-in Period: The integrated blowers in this Insert may exhibit some bearing noise and electrical static noise during the first few hours of operation. This is normal during the break-in period.

Paint Types Approved for Use: Industrial Acrylic Paints, Alkyd based Paints. When selecting Paint for applications on facings, mantels, corbels or floors within 2 feet in front of a fireplace raised 6" or higher, avoid off the shelf Paints which may have modifier additives used to increase "hiding" ability and accelerate drying times and curing times. Consult with a reputable Paints and Sealants supplier and acquire Industrial Acrylic Paints or Alkyd based Paints.

Sealant Types Approved For Use: Heat resistant polyurethane sealants which are not damaged by prolonged exposure to raised temperatures. Many are flame resistant, meaning that they resist ignition when exposed to high temperatures and can insulate the substrate and delay damage to it. When selecting polyurethane for applications on facings, mantels, corbels or floors within 3 feet in front of a fireplace, avoid off the shelf urethane Sealants which may have modifier additives used to accelerate drying times and curing times. Consult with a reputable Paints and Sealants supplier and acquire Heat Resistant Polyurethane Sealants.

Additional Application Cautions: If wood used around or in front of the fireplace has been chemically cleaned or bleached prior to staining or painting, it is of the utmost importance to make certain that the cleaner or bleach does not remain in the wood substrate under the final paint or sealant applied. If any cleaner or bleach remain within the wood structure, application of heat from the fireplace, even low level heat, will cause the cleaner or bleach compounds to expand or evaporate causing separation of the paint or sealant from the wood surface and may cause peeling or bubbling of the paint or sealant.

Moisture Content of the wood substrate is also of critical importance. High moisture content wood when heated will yield evaporation of the moisture and hydraulic pressure under the paint or sealants which can lead to peeling or bubbling. Always select the lowest moisture content wood substrate. Store the wood substrate in an environment with 60-75 degrees F and 35-55% relative humidity levels for a minimum of 48 hours before applying the Paint or Sealant.

SPECIFICATIONS

General Specifications

This Mendota insert must be installed in an existing Masonry Wood Burning Fireplace or a Factory Built ZC Wood Burning Fireplace. This Mendota insert must be installed and serviced by a Mendota approved technician.

MINIMUM FIREPLACE CAVITY SIZE REQUIREMENT: 29-5/8" WIDE X 19" HIGH X 17-5/8" DEEP

ELECTRICAL REQUIREMENTS: 120 Volts AC, 1.5 Amps (minimum line voltage allowed 110 Volts AC)

REQUIRED GAS SUPPLY PRESSURE: NAT. GAS: 7" W.C. [5.0" W.C. MIN., 11" W.C. MAX.]
L.P. GAS: 11" W.C. [11" W.C. MIN., 13" W.C. MAX.]

LP GAS CONVERSION KIT: This insert comes configured for use with Natural Gas.
To convert the insert for use with LP Gas install: LP GAS CONVERSION KIT HA-82-00411.

		<u>High Fire</u>	<u>Low Fire</u>
<u>BTUH</u>	NAT. GAS	31,000	10,000
<u>BTUH</u>	L.P. GAS	31,000	13,000
<u>ORIFICE SIZE</u>	REAR BURNER:	#49 NAT. [3/64" LP]	
	FRONT BURNER:	#45 NAT. [3/64" LP]	

P.4 EFFICIENCY76%

FLUE VENTINGCO-LINEAR - 4" DIAMETER EXHAUST & 3" DIAMETER INLET

APPROVED VENTS

- Duravent brand Insert Vent Kits with 3" X 4" Liners and Vent Cap
- Duravent brand 3" X 4" Liners, 3" X 4" to 4" X 6-5/8" Coaxial Chimney Top Adapter and High Wind Cap
- ICC brand EXELDirect 3" X 4" Liners and Vent Cap
- BDM brand 3" X 4" Liners and Vent Cap
- RLH brand 3" X 4" Liners and Homestyle Series Co-Linear Insert Caps models HS-C43 (4X3)

NET WEIGHT.....160 lbs.

SAFETY SCREEN: A safety screen that has been certified for use with this insert must be installed on the insert when it is in use. The safety screen will prevent accidental contact with the glass door face, which could result in a severe burns.

SAFETY: AGA certified, electronic ignition IPI system activated with thermostatic remote control.

CERTIFIED TO: ANSI Z21.88 / CSA 2.33 – 2014, CGA 2.17
This Mendota Gas Fireplace Insert has been tested and certified by:
Intertek Testing Services
8431 Murphy Drive, Middleton, WI 53562

Overall Dimensions

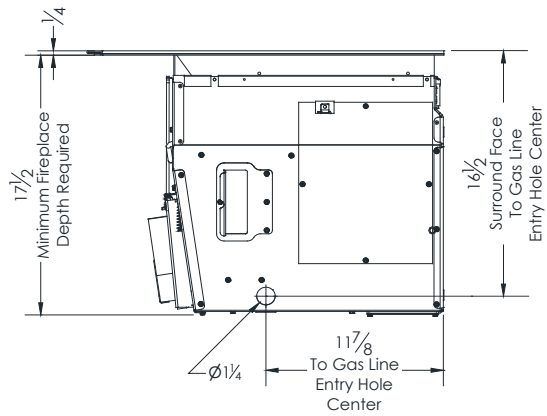
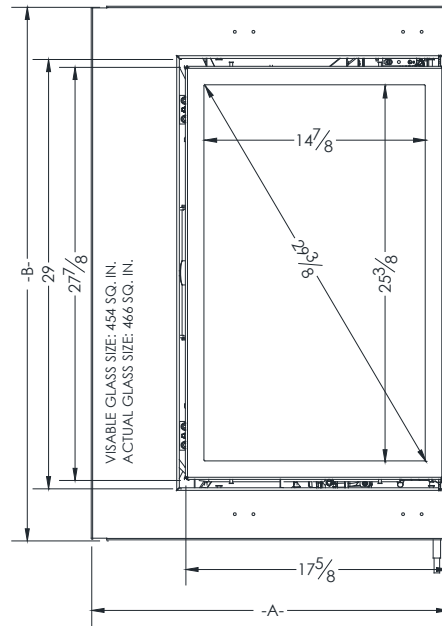
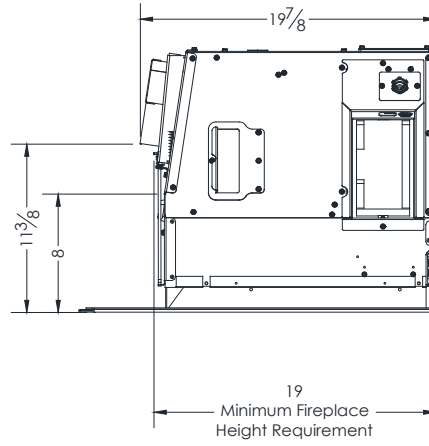
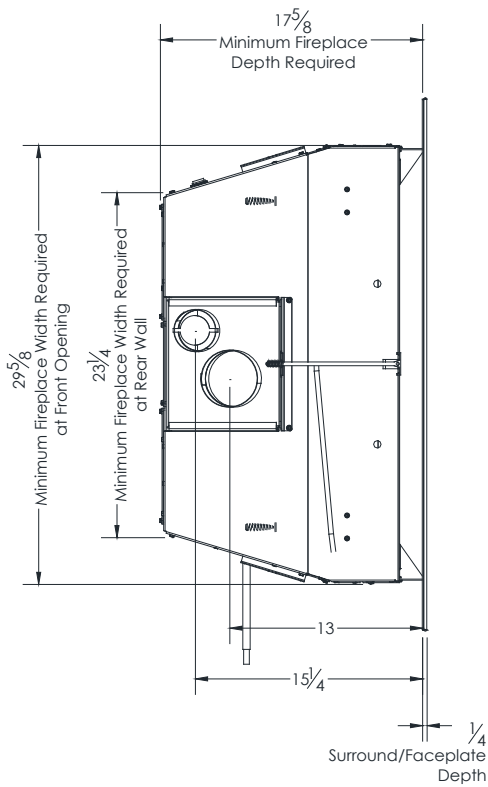

Required Clearances

ATTENTION: MIN required WIDTH & DEPTH are dependent on the type of surround that is used.

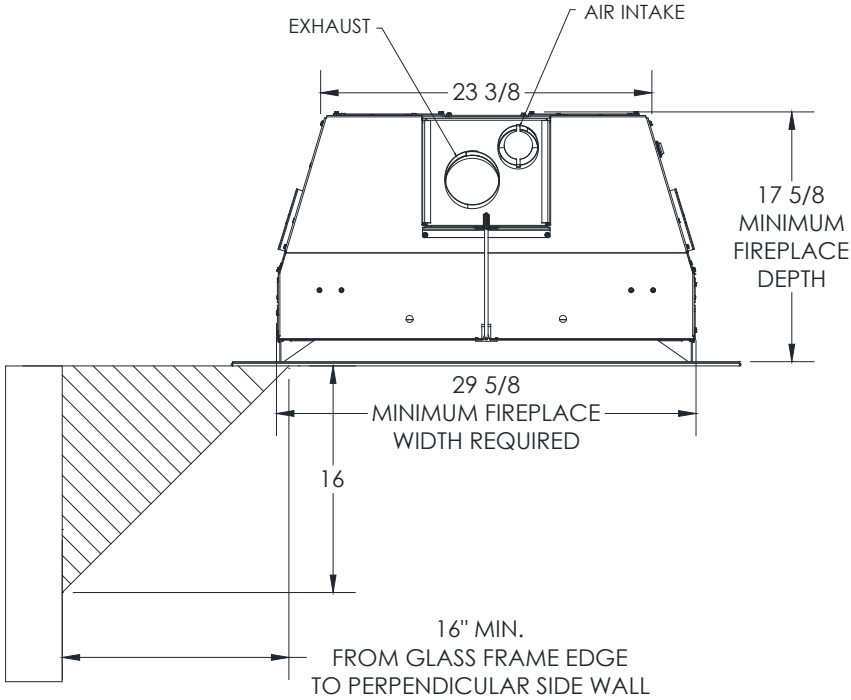

Minimum Allowable Fireplace Opening

With 1/2" Outer Edge Return Surround
29-5/8" wide X 19" high X 17-3/8" Deep

With Flat Surround
29-5/8" wide x 19" high x 17-5/8" Deep

NOTE: Min required depth is dependent on the Outer Edge Return on surround

FV-33i Surrounds Dimensions

	A		B	
	Inches	mm.	Inches	mm.
No Trim	24	610	36	914
	27	686	40	1016
	31	788	44	1118

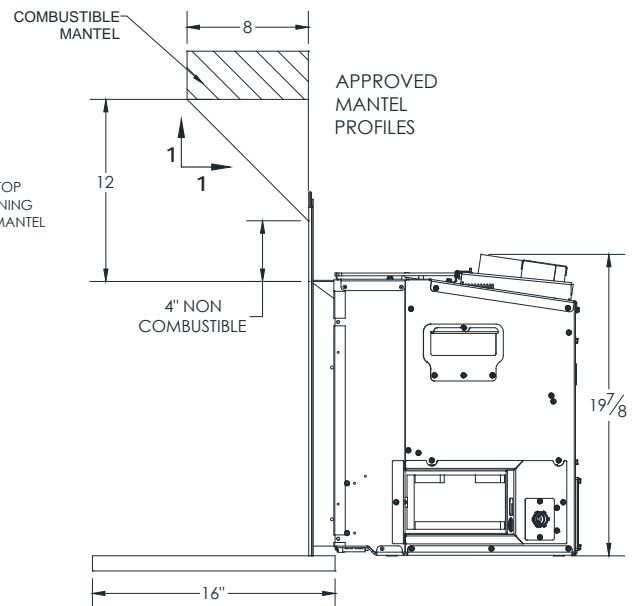
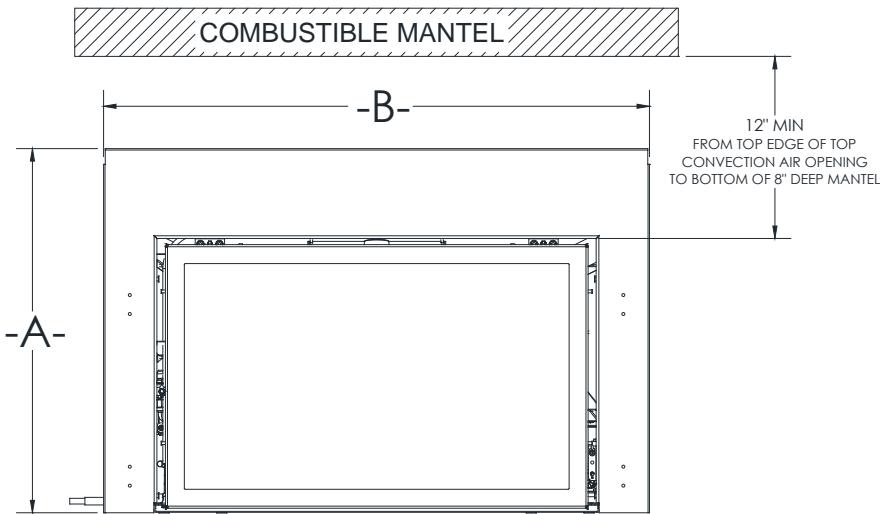

HEARTH PROTECTION PAD REQUIRED IF NOT ELEVATED.
FOR EVERY 1-INCH THE UNIT IS ELEVATED, HEARTH PROTECTION PAD DEPTH MAY BE REDUCED BY 2". IF ELEVATED 6" OR MORE, NO HEARTH PROTECTION PAD IS REQUIRED.

MANTEL INFORMATION

The existing Combustible Mantel must fall within the approved mantel profile chart. If it does not, either remove and relocate the combustible mantel at an approved height or add a 20 gage metal shield underneath the combustible mantel that extends the full width and depth of the combustible mantel. Provide a 1" active air space between the metal shield and the bottom surface of the combustible mantel. Use ceramic spacers to create the 1" active air space.

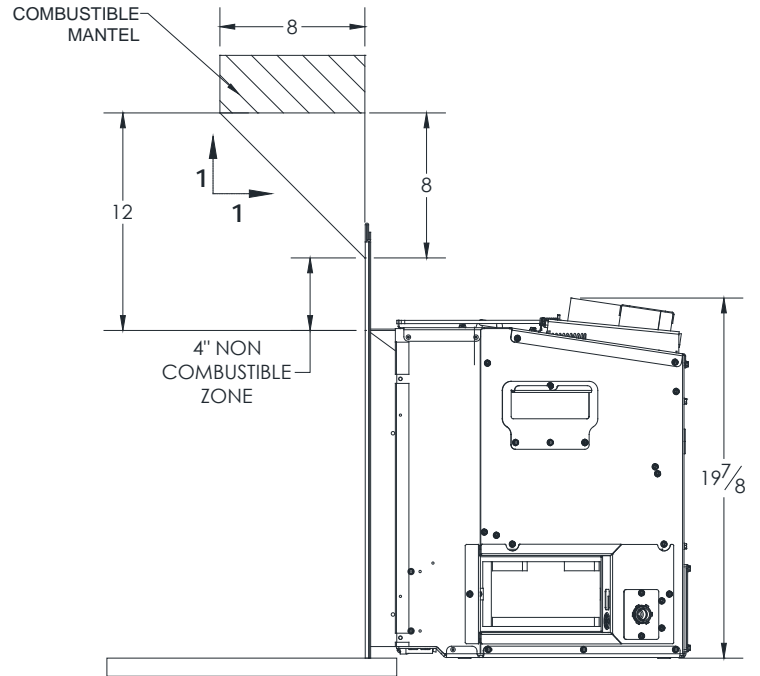
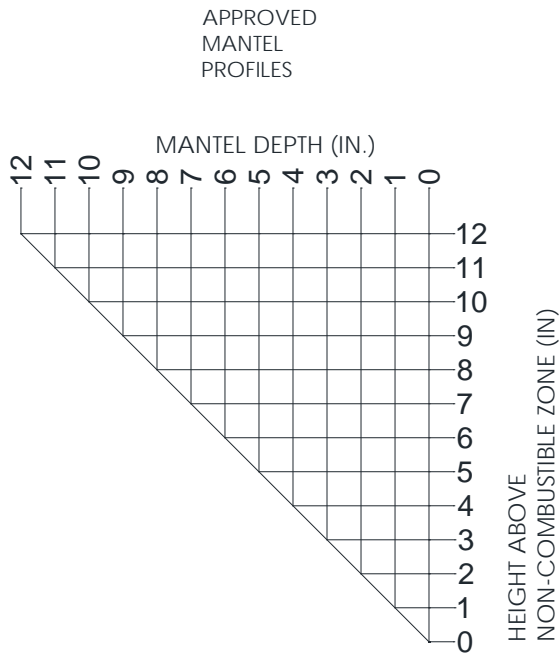

Figure 1 - APPROVED MANTEL PROFILE CHART

HEARTH PROTECTION PAD REQUIREMENTS

In most installations, a 16" non-combustible protector is required in front of the unit's glass door surface on the floor or raised hearth. This protection must have a minimum total R-value of 1.0. Different non combustible materials can be layered to achieve the R-1 value. Refer to the tables below for R-values of common backing and finishing materials.

Backer Materials R-Ratings Table

R-Values of common Backer Materials			
<i>Material</i>	<i>Thickness</i>	<i>R-Value</i>	<i>Note</i>
Mineral Fiber Board (Backer 160)	1/2"	1.270	
Mineral Fiber Board (Backer 300)	1/2"	1.030	
Ceramic Board (Rescor 360)	1/2"	1.110	
Ceramic Board (Fiberfrax Duraboard LD)	1/2"	1.100	
Common Brick	2-1/4"	0.450	
Common Brick	4"	0.800	
Gypsum or Plaster Board	1/2"	0.450	
Cement Board (Durock Next Gen)	1/2"	0.390	
Cement Board (Wonderboard)	1/2"	0.260	
Cement Board (Hardibacker 500)	1/2"	0.200	
Cement Board (Hardibacker)	1/4"	0.130	

Finishing Materials R-Ratings Table

R-Values of common Facing Materials		
<i>Material</i>	<i>Thickness</i>	<i>R-Value</i>
Cement Mortar	1/2"	0.100
Concrete	1"	0.095
Ceramic Tile	1/4"	0.020
Flagstone	1"	0.079
Granite	1"	0.083
Limestone	1"	0.153
Marble	1"	0.090
Sandstone	1"	0.079
Slate	1"	0.100

If a raised hearth extends less than 16" in front of this Insert, refer to the diagram below and the following procedure to see if additional floor protection is required.

For installations where the fireplace is raised 6" or more above the floor of the room, or if the existing floor in front of this Insert is non-combustible (stone, brick, etc.), a non-combustible protector is not required.

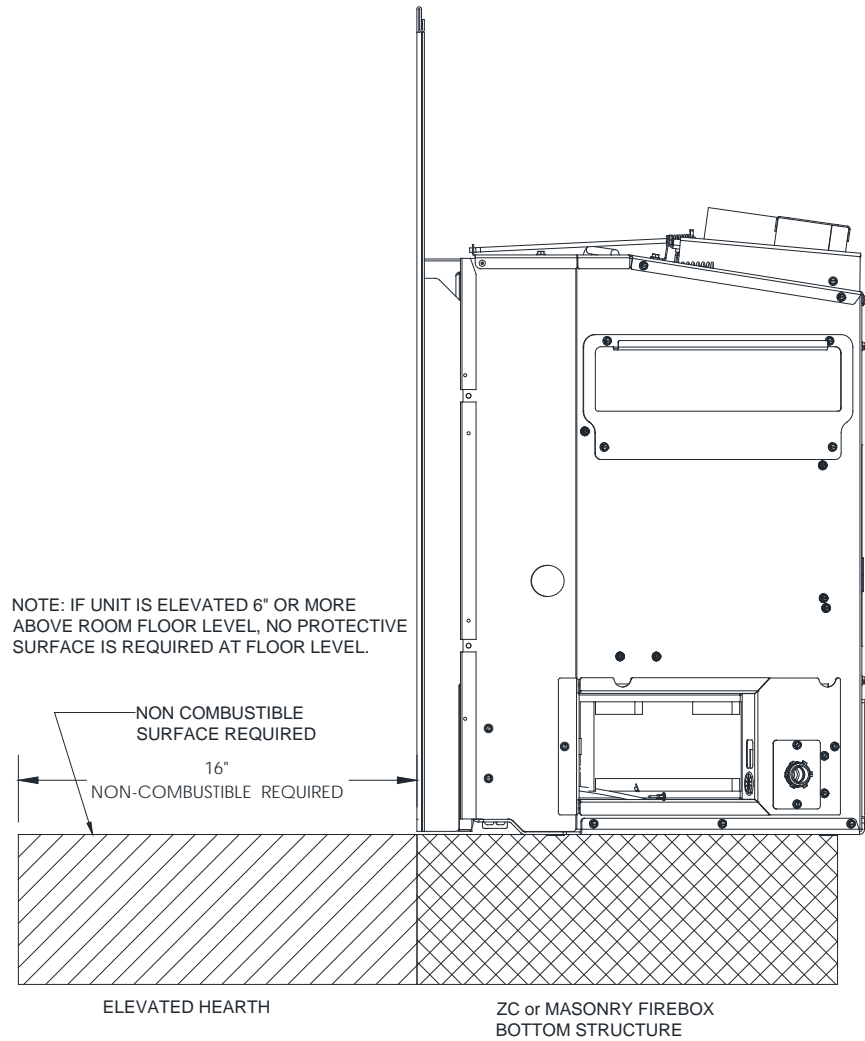

NOTE: For every 1" this fireplace is raised off the floor, the non-combustible hearth protection pad may be reduced by 2". If this fireplace is raised off the floor more than 6", No hearth protection pad is required.

VENTING REQUIREMENTS

General Venting Requirements

This Insert must be vented vertically to the outside and must use the Mendota Co-Linear flexible ducting system. **Note: Run both the 4" exhaust liner and 3" air intake liner to the Vertical Vent Cap. Pack around the liners at the damper area to create an air tight seal. If existing wood burning vent size is too small to run both 4" and 3" liners, consider converting to a coaxial flex system using a 4" exhaust flex and 6" air intake flex with spring spacers between the two flex pipes.**

NOTE: THE INSERT IS DESIGNED, TESTED AND LISTED FOR OPERATION ONLY WITH MENDOTA INSERT VENTING COMPONENTS AS LISTED IN FIGURES BELOW:

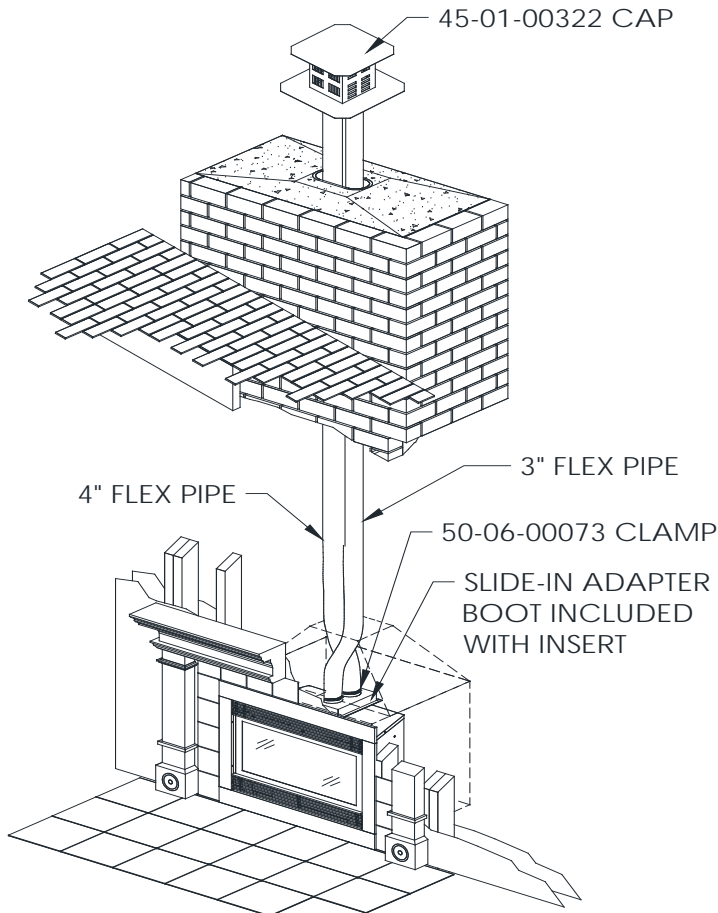

NOTE: Mendota recommends that both exhaust and air intake flex liners be run all the way to the vent cap. Seals between flex liners and unit top and vent cap must be air tight. Use both securing screws and hose clamps at all four flex connection points.

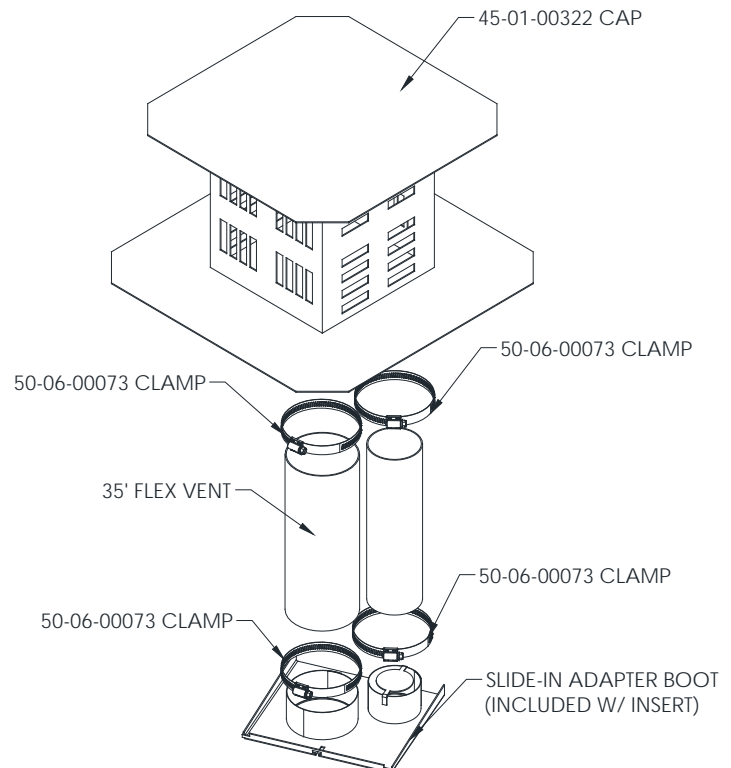

Venting Installation Instructions

CAUTION: Each installation must conform to all local, state and national codes. Refer to the national fuel gas code and local zoning and code authorities for details on installation requirements. The Mendota Inserts must be vented to the outside in accordance with the latest edition of the National Fuel Gas Code. In the absence of local codes, the installation must conform with National Fuel Gas Code ANSI Z223.1 (NFPA 54), or Canadian Code CAN1-B149 or most current edition, also known as NFPA 54. Do not connect this Insert to a chimney flue serving a separate solid fuel or gas-burning appliance.

1. Remove glass doors, metal fire screens, etc. from existing fireplace. Be sure there is 12" minimum distance from top of upper grill to bottom of mantel and a 16" minimum non-combustible hearth extension in front of the glass surface if a raised hearth is not supplied..
2. Remove any additional framework or other obstructions in the existing fireplace opening and burning area. Also remove any chimney cap from top of chimney so that vent liner can be installed freely.
3. Before Insert is installed, have gas supplier or contractor run gas line to the existing fireplace. Be sure gas plumbing instructions are carefully followed. Gas supply may enter fireplace on the left side or back left side of fireplace, whichever is most convenient and accessible. Electrical service (120 volt) should also be supplied to the right side of the appliance.
4. The entire chimney should be swept to remove creosote, soot and any obstructions (bird nests, etc.).
5. Open fireplace damper. If damper opening is large enough to accept the 4" and 3" flue liners, permanently secure damper in "open" position. **NOTE:** *Massachusetts requires that the flue damper must be removed or permanently welded in the "open" position.*
6. If damper opening is too small for the 4" & 3" flue liners, it will be necessary to remove the damper handle and the damper plate. Some damper plates are held in place by a pinned hinge that can be released easily by tapping out the pin with a hammer and punch. Others may be held in place by a screw or bolt, or pivots may be cast into the damper housing. The latter types may be harder to get out and may require sawing or breaking out. [NOTE: if flue size is 6" (127 mm) or less, or if severe offsets occur, or a significant mortar slop is evident between the liners, try to snake liner down the chimney to the top of the damper housing before breaking out damper plate and housing.]

CAUTION: If the 4" & 3" flue liners cannot be installed in an extremely tight chimney DO NOT proceed with installation.

7. If damper opening is narrower than 4-1/2" to 5" (114 mm to 127 mm) and if local code authorities allow, loosen and remove mortar behind back side of damper housing in the center of the opening enough to get the gripping teeth of a pipe wrench over the flange of the damper housing (for cast iron housings). Tighten the wrench snugly, and kick down on the wrench handle to break out a half moon shaped piece of the damper housing, enough to easily fit the flex liner through it. If the opening is wide enough, the break out is not necessary.
8. **Install Insert only in chimney heights of 12' (minimum) to 55' (maximum) -- as measured in step 9, see next page.**
9. Measure the chimney height from the top of the chimney (or the existing flue liner) to a point 24" (610 mm) above the floor of the fireplace hearth. It may be necessary to drop a rope and measure the rope itself. Be sure to allow for all offsets in existing chimney. Cut the 4" diameter flex liner (s) to this measured length.
10. Attach a sheet metal strap loop to the flex end of the liner(s) and tie a rope to it. Two installers should proceed to the roof and drop the rope (with weight on the end to make sure it goes all the way down) and insert the 4" liner(s) past the flexible portion, into the existing chimney – SEE NEXT PAGE:
11. One installer should then return to the fireplace opening and pull the rope to guide the liner(s) into place through the smoke shelf and the damper opening to a point 22" (560 mm) above the fireplace hearth. The person below should wear leather gloves and Safety Glasses during this process to avoid being cut and to safeguard eyes from flying debris.

CAUTION: WHEN USING FLEX ALUMINUM LINER, USE EXTREME CAUTION WHEN STRETCHING LINER AROUND OFFSETS SO AS NOT TO RUPTURE LINER.

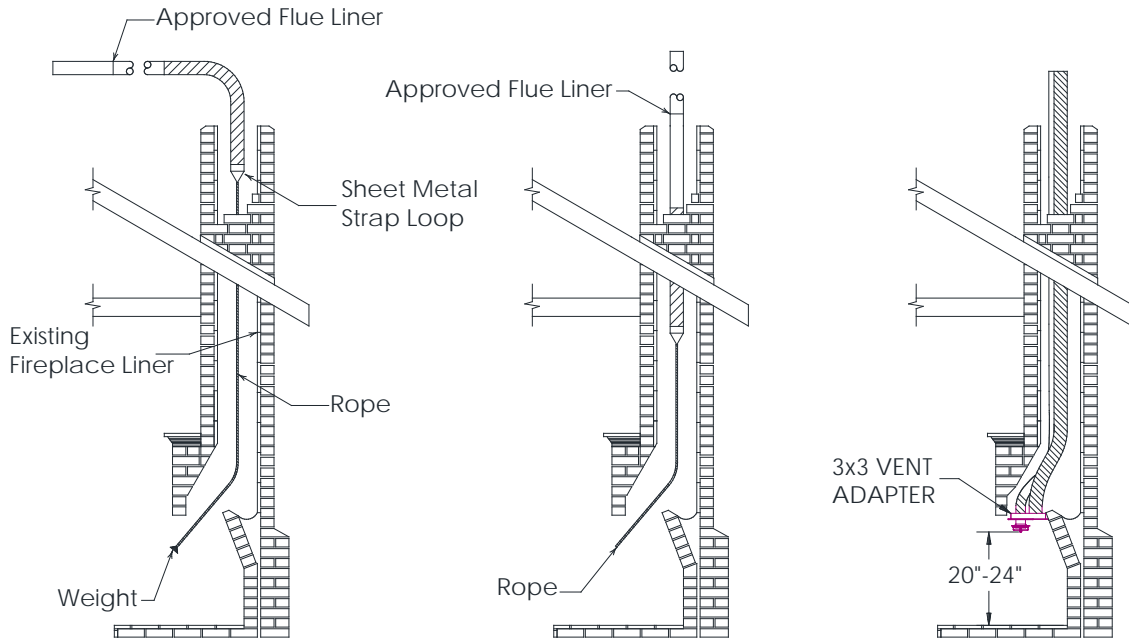

12. Remove the Vent Adapter by unlatching spring loaded lever from front of the unit
13. Tightly secure 3" and 4" flex vents with clamps provided. Seal vent cap/flashy to top of chimney with weatherproof sealer. Seal areas between flex pipes and existing chimney, at damper area, with unfaced fiberglass insulation.
14. Carefully slide Insert into the fireplace opening (Note: Plug in the AC Power cord to a 110 volt AC receptacle inside the fireplace opening or extend it out and connect to a grounded wall outlet.
15. Slide Vent Adapter forward between guide rails. Vent Adapter's front flat section should contact insert top as you slide the Vent Adapter forward.
16. Use Spring loaded lever to pull Vent Adapter back into place on the unit and then latch it to front of unit.
17. You are now ready to hook up the Insert to gas supply. Be sure gas plumbing instructions and all state and local codes have been carefully followed. Be sure all items on Installation Check-Off List have been completed.

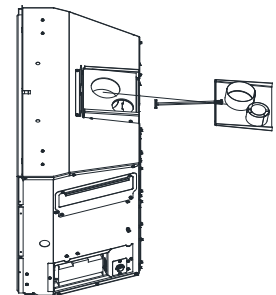
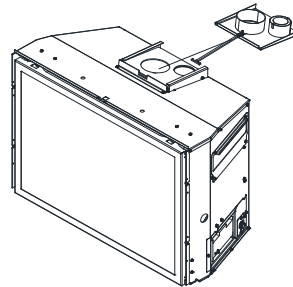
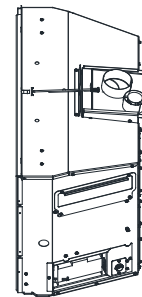
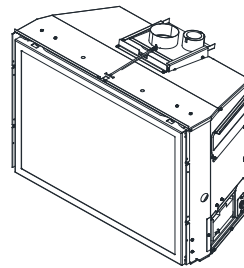

NOTE: AGA APPROVED FLEX LINES ARE APPROVED FOR USE WITH MENDOTA INSERTS.

18. Carefully slide the Insert into place in the fireplace opening. At this time, check that Insert is level and plumb with the fireplace opening and positioned in the middle of the opening. If Insert is unsteady or needs leveling, the unit may need to be "shimmed" with washers under the bottom corners of insert.
19. The proper Insert Faceplate can now be placed in position. Assemble surround by following instructions supplied with faceplate kit. Select the appropriate size of faceplate to cover the area between the Insert and existing fireplace opening.

IMPORTANT

INSTALLATION, SERVICING AND REPAIR MUST BE DONE BY A QUALIFIED SERVICE PERSON. THE INSERT SHOULD BE INSPECTED AT LEAST ANNUALLY BY A PROFESSIONAL SERVICE PERSON. MORE FREQUENT CLEANING MAY BE REQUIRED DUE TO EXCESSIVE LINT DEPOSITS FROM CARPETING, BEDDING MATERIAL, ETC. IT IS IMPERATIVE THAT THE CONTROL COMPARTMENT BURNERS AND CIRCULATING AIR PASSAGEWAYS OF THE INSERT BE KEPT CLEAN.

Vent Damper Setting

The insert's Vent Adapter has a damper plate located on the 3" air intake tube. The Vent Damper comes from the factory set at a 45 deg. position. Set the damper according to the length of venting used.

- Below 20 ft. leave in the factory position.
- Above 20 ft. close approximately 15 deg. for every 10 ft. above 20 ft.
- Above 50 ft. close fully.

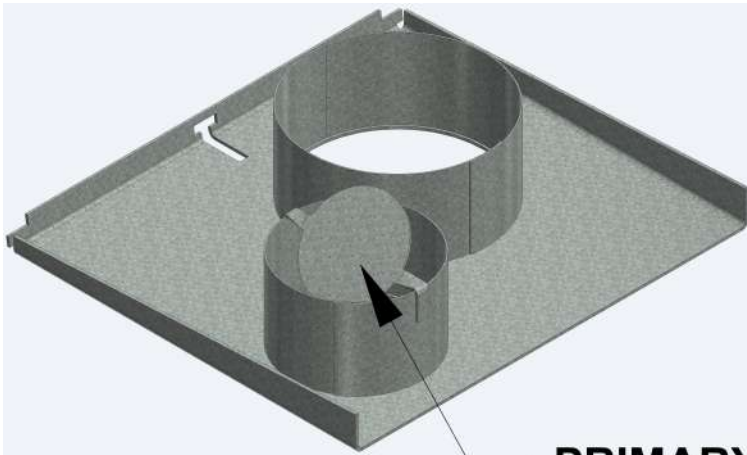

PRIMARY VENT DAMPER
SHOWN IN 45° FACTORY ADJUSTED POSITION

ELECTRICAL REQUIREMENTS

WARNING: Label all wires prior to disconnection when servicing controls. Wiring errors can cause improper and dangerous operation. Verify proper operation after servicing.

If this appliance is installed with a three-prong (grounding) plug for protection against shock hazard, it should be plugged directly into a properly grounded three-prong receptacle. Do not cut or remove the grounding prong from the plug.

For normal operation, this appliance requires 120 VAC, 2 Amp power or a 6V DC power source.

This appliance is equipped with an electrical junction box on the right side and a 6V DC power inlet connector located directly below the Master Switch on the right side, adjacent to the glass frame's right edge. The Manual Packet accompanying this appliance also includes a 4XAA Battery Pack and a connector wire harness that is designed to be used as the 6V DC power source during electrical power outage conditions.

Planning for AC 120 VAC Connection

Two options exist for supplying 120 VAC power to this appliance:

1. Connect the 8 foot grounding plug extension cord supplied in the Manual Packet to the Junction Box on the right side using the three wire nuts supplied and run the extension cord out of the fireplace cavity to a wall electrical outlet in the room.
2. Run Metal Flex Conduit encapsulated Romex 14-2 cable from an approved electrical junction in the home directly to the Junction Box on the right side of this appliance and connect to the three color coded wires within the junction box using the three wire nuts supplied. Make certain to leave a 24-inch long excess loop of the Metal Flex Conduit encapsulated Romex within the fireplace cavity to allow removal of this appliance from the fireplace cavity during cleaning and service work.

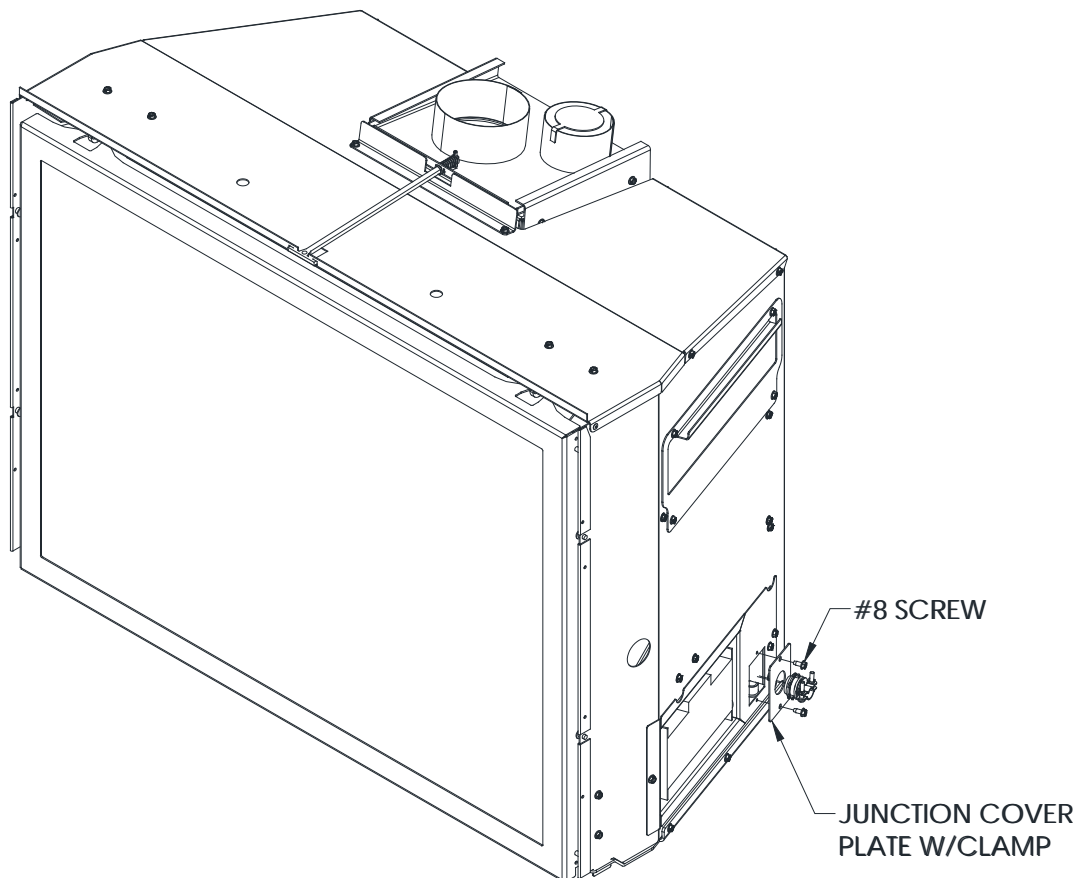

Backup DC Power Connection

This appliance is factory equipped with a Backup DC Power Connection Port. The Inlet Port is factory mounted on the right side above the remote sync button, and master power switch. This port can be utilized in combination with the battery pack supplied with the unit in the event of a power outage to supply power to the unit.

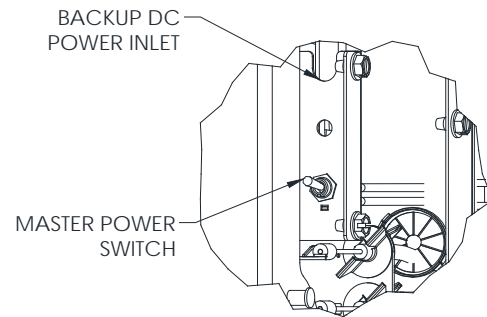
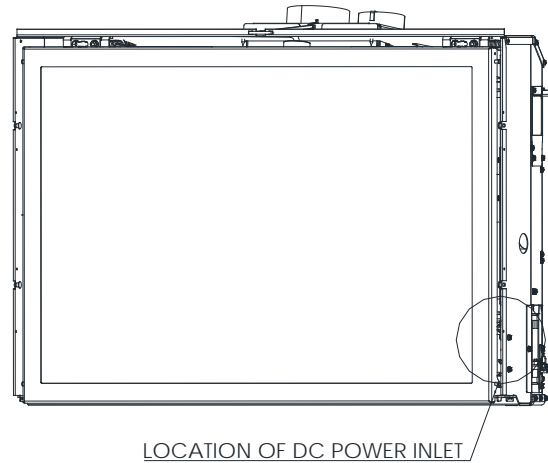

Operating During Power Outages

This electronic ignition system utilizes the supplied 110VAC power when it is available for all functions of this system. If the AC power is interrupted during a power outage, plug in the battery pack (6V DC Max, supplied with this fireplace) to the Fireplace Backup Power Inlet Port.

During the power outage, the appliance's burner will function as well as the Flame Height adjustment. The Fan and Accent Light, which are wholly dependent on 110VAC power, will not function.

You may operate this appliance indefinitely on battery power as long as you accept that high capacity DC 6 volt batteries will be required to sustain uninterrupted DC power to this appliance and that the blower function and accent light functions will not be available.

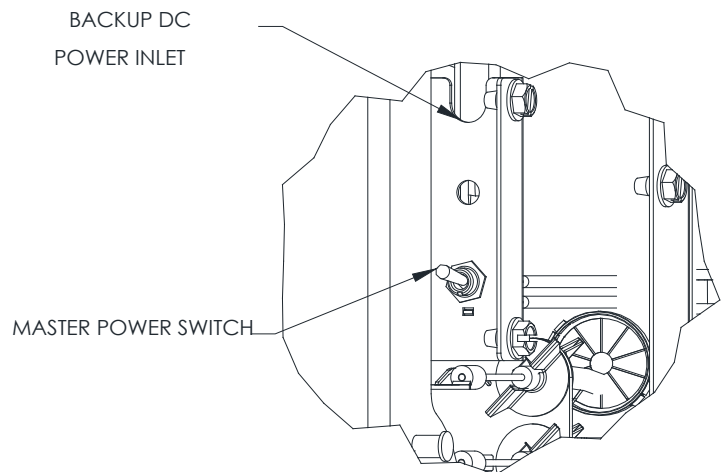

GAS SUPPLY REQUIREMENTS

NOTE: IF INSERT IS TO BE OPERATED WITH LP GAS, SEE “LP CONVERSION INSTRUCTIONS” SECTION OF THIS MANUAL BEFORE PROCEEDING.

CORRECT GAS PRESSURE AND PROPER GAS SUPPLY LINE SIZING IS IMPERATIVE TO THE SUCCESSFUL PERFORMANCE OF YOUR MENDOTA GAS FIREPLACE INSERT. BE SURE THE GAS SUPPLIER OR PLUMBER CAREFULLY CHECKS FOR CORRECT GAS PRESSURE AND GAS LINE SIZING WHEN INSTALLING THE FIREPLACE INSERT.

IT IS CRITICAL TO CAREFULLY CHECK FOR GAS LEAKS WHEN HOOKING UP THE FIREPLACE INSERT -- CHECK WITH SOAP & WATER SOLUTION.

BE SURE TO INSTALL FLEX GAS LINE WITH BRASS-TO-BRASS FITTINGS TO PREVENT GAS LEAKS AT CONNECTIONS.

GAS SUPPLY PIPING MUST INCLUDE A DRIP LEG TO ELIMINATE THE POSSIBILITY OF CONTAMINANTS ENTERING THE GAS TRAIN. ADHERE STRICTLY TO LOCAL AND NATIONAL CODES.

Gas Supply Line Sizing

The Mendota Gas Insert comes equipped with a 3/8" NPT [1.0 cm] inlet on the main gas valve. Gas supply piping may enter the cabinet from either the left or left rear side. A 48" X 3/8" SS Flex supply line is supplied in the Manual Packet with this Insert.

The proper gas line diameter must be selected to run from the supply regulator to the Insert. Refer to the following table for proper gas pipe diameters.

PIPE LENGTH [FEET]	SCHEDULE 40 PIPE INSIDE DIA.		TUBING, TYPE L OUTSIDE DIA.	
	NAT.	L.P.	NAT.	L.P.
0-10	1/2" [1.3 cm]	3/8" [1.0 cm]	1/2" [1.3 cm]	3/8" [1.0 cm]
10-40	1/2" [1.3 cm]	1/2" [1.3 cm]	5/8" [1.6 cm]	1/2" [1.3 cm]
40-100	1/2" [1.3 cm]	1/2" [1.3 cm]	3/4" [2.0 cm]	1/2" [1.3 cm]
100-150	3/4" [2.0 cm]	1/2" [1.3 cm]	7/8" [2.3 cm]	5/8" [1.6 cm]
150-200	3/4" [2.0 cm]	1/2" [1.3 cm]	7/8" [2.3 cm]	3/4" [2.0 cm]

NOTE: Some areas allow copper tubing or galvanized pipe - check with local approval agencies and codes NEVER use plastic pipe.

Gas Pressure Checking

A pressure tap for checking gas pressure is located on the main gas valve. A qualified installer should use this fitting for setting the correct gas pressure during initial installation.

If supply gas pressures exceed 1/2 PSIG [3.5KPA], the appliance must be isolated from its supply with the factory installed manual shut-off valve. This manual shut-off valve must be closed during any supply line pressure testing. Check with your gas supplier or plumber.

If the factory-built fireplace has no gas access hole(s) provided, an access hole 1.5" or less may be drilled through the lower sides or bottom of the firebox in a proper workmanship like manner. This access hole must be plugged with non-combustible insulation after the gas supply line has been installed.

The Manual Gas Shutoff Valve is located within the left-side convection chamber. To manipulate the Manual Gas Shutoff Valve, insert the tip of the glass latch tool into the hole in the VALVE ACTIVATION BRACKET. Rotate the tool Clockwise 90 Degrees or until it stops to fully close the Valve. To Open Valve, insert tool in VALVE ACTIVATION BRACKET rotate tool Counter-Clockwise 90 degrees or until it stops.

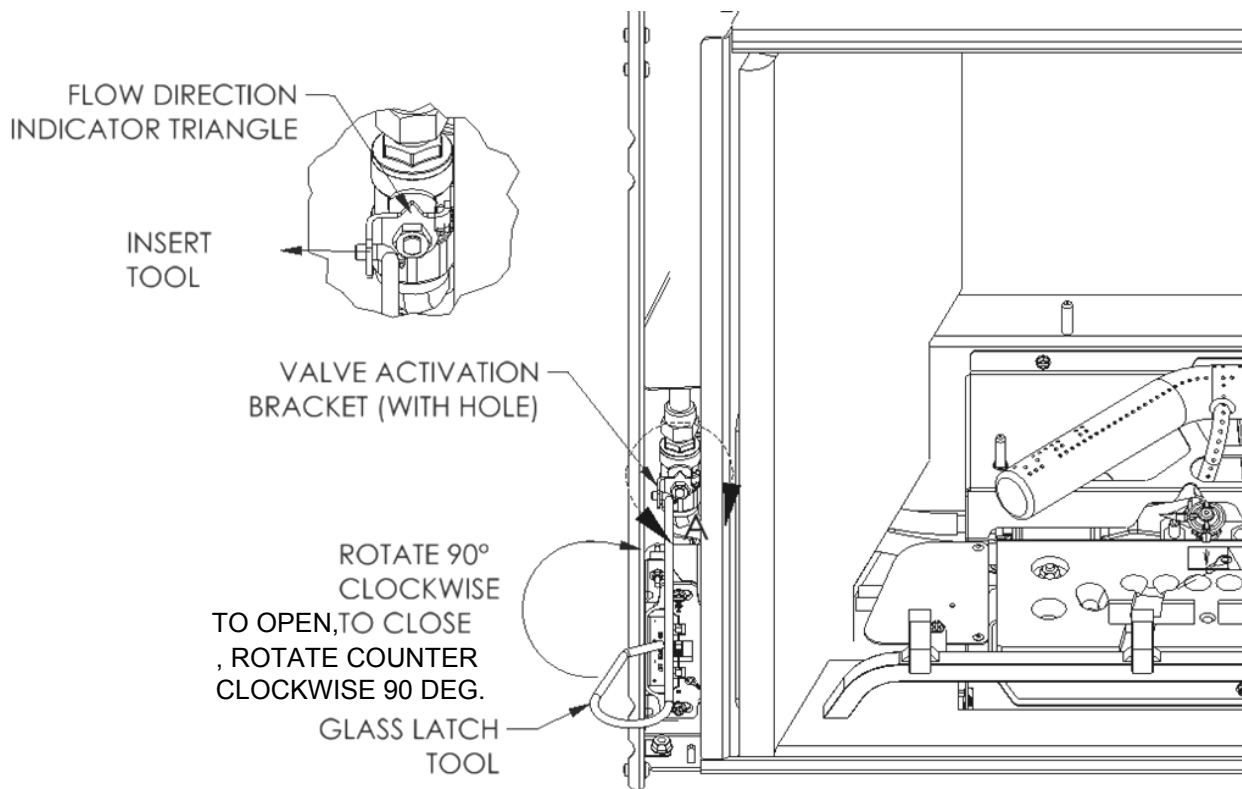

Gas Input Rate Verification

Natural Gas Input Rate Verification

Verify Main Orifice Size. The main orifice body has the orifice hole size stamped on it. NG orifice size shall be #49 (Rear Burner) and #45 (Front Burner) for all elevations in between 0-2000ft. NG orifice size shall be #49 (Rear Burner) and #46 (Front Burner) for all elevations exceeding 2000ft.

Verify that the Manifold Gas Pressure is within 3.5" WC +/- 1/8".

Once setup, read the main home gas supply meter reading.

Write the initial reading here >> Initial Gas Meter Reading _____

Turn OFF all other appliances and their pilot flame in the home.

Run this appliance for a period of 30 minutes on maximum flame size. Turn off main burner and pilot flame.

Read the main home gas supply meter reading after the 30 minutes of burn time.

Write the reading here >> Final Gas Meter Reading _____

Calculate the following:

FINAL GAS METER READING - INITIAL GAS METER READING... Subtract Initial Gas Meter from Final Gas Meter Reading. This will yield the number of Therms used during the 30 minute burn time.

Multiply the result in Item 11 by 100,000.

Multiply the result in Item 12 by 2. Write down the Result here >> _____

The result in item #13 shall be at least maximum Input Rate (31,000 Btu) for altitudes below 2000 Feet. For altitudes higher than 2000 feet, the result in item #13 shall be at least 31,000 Btu.

LPG Input Rate Verification

Verify Main Orifice Size. The main orifice body has the orifice hole size stamped on it. LPG orifice size shall be 3/64" (Rear Burner) and 3/64" (Front Burner) for all elevations below 2000 Feet. For elevations higher than 2000 feet, the orifice size shall be 3/64" (Rear Burner) and 3/64" (Front Burner).

Verify that the Manifold Gas Pressure is within 10.0" WC +/- 1/8".

High Altitude De-Rating

If you are de-rating this appliance at a high altitude, attach the High Altitude De-Rating Label, supplied in the Owner's Manual Packet, to the back surface of the listing label plate located in the air gap on the side of the insert. If you are also converting the insert for LP Gas attach the labels included with the conversion kit to the same surface.

Prior to attaching the label, fill in all the information that is requested on the label.

For installations from 610-1370 meters (2000-4500 ft.) the orifice sizes (DMS) for Natural Gas are #49(Rear) and #46(Front) and Propane Gas are 3/64"(Rear) and #56(Front), respectively. See data plate for additional information. For high altitude installations consult the local gas distributor or the authority having jurisdiction for proper rating methods. If the installer must convert the unit to adjust for varying altitudes, the information sticker must be filled out by the installer and adhered to the appliance at the time of conversion."

This appliance has been converted for use at an altitude of _____

Orifice size _____ Manifold Pressure _____

Input (Btu/h) _____ Fuel Type _____

Date of conversion _____ Converted by _____

«Cet appareil a été converti au _____

Injecteur _____

Pression à la tubulure d'alimentation _____

Débit calorifique _____

CONVERTING INSERT FOR LP GAS

This conversion kit shall be installed by a qualified service agency in accordance with the manufacturer's instructions and all applicable codes and requirements of the authority having jurisdiction. If the information in these instructions is not followed exactly, a fire, explosion or production of carbon monoxide may result causing property damage, personal injury or loss of life. The qualified service agency is responsible for the proper installation of this kit. The installation is not proper and complete until the operation of the converted appliance is checked as specified in the owner instructions supplied with the kit.

Cet équipement de conversion sera installé par une agence qualifiée de service conformément aux instructions du fabricant et toutes exigences et codes applicables de l'autorisés avoir la juridiction. Si l'information dans cette Instruction n'est pas suivie exactement, un feu, explosion ou production de protoxyde de carbone peut résulter le dommages causer de propriété, perte ou blessure personnelle de vie. L'agence qualifiée de service est esponsable de l'installation propre de cet équipement. L'installation n'est pas propre et complète jusqu'à l'opération de l'appareil converti est chèque suivant les critères établis dans les instructions de propriétaire provisionnées avec l'équipement.

Kit # HA-82-00411 for Mendota Model FV-33i

This conversion kit shall be installed by a qualified service agency in accordance with the manufacturer's instructions and all applicable codes and requirements of the authority having jurisdiction. If the information in these instructions is not followed exactly, a fire, explosion or production of carbon monoxide may result causing property damage, personal injury or loss of life. The qualified service agency is responsible for the proper installation of this kit. The installation is not proper and complete until the operation of the converted appliance is checked as specified in the owner instructions supplied with the kit.

Caution: The electrical supply to the fireplace must be turned off prior to performing the conversion. The gas supply must be shut off prior to disconnecting the electrical power.

Orifice Size Requirement

A Natural Gas to LPG conversion kit #HA-82-00411 must be ordered and installed to convert the FV-33i Fireplace to burn LPG.

LP Conversion Kit # HA-82-00411 contains the following parts: One Motorized LP Pressure Regulator #907.012 and two Cap Orifices (drill $\frac{3}{64}$ ").

Procedure to Convert Insert for LP Gas

This Fireplace Insert arrives from the factory ready to burn Natural Gas. If you intend to burn LPG, it is highly recommended that you convert this fireplace's Pressure Regulator, Pilot Orifice Slider and Burner Orifices prior to placing this fireplace in its fireplace cavity.

See diagrams, on this page, and follow these instructions to prepare this fireplace for conversion to LPG.

WARNING: It is of the utmost importance that the correct burner orifices be installed for both the rear and front burners.

See diagrams, on this page, and follow these instructions to prepare this fireplace for conversion to LPG.

1. Using a $\frac{1}{4}$ " hex driver, remove 2 screws that secure the rear and front burners to the burner airbox
2. Lift up and remove front burner.
3. Loosen front burner air shutter screw and rotate air shutter open $\frac{1}{4}$ " minimum. Set burner aside.
4. Slide rear burner to the right about 2" and lift up, remove from firebox.

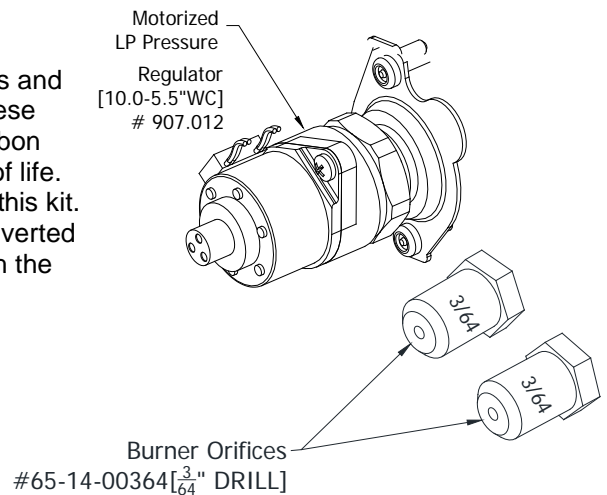
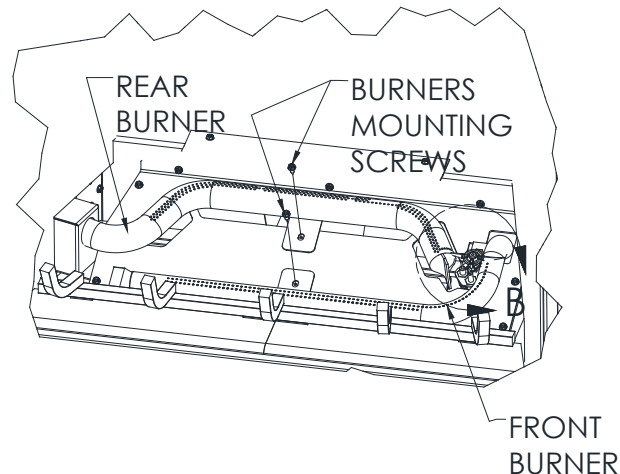

5. Using a 1/2" deep well socket wrench, remove front and rear orifices.
6. Thread in new 3/64" drilled orifices to both front and rear orifice mounting brass fittings. Tighten down orifices.
7. Remove the left-side access panel mounted to the left outer skin and lay down gently without disconnecting any wires of internal components.

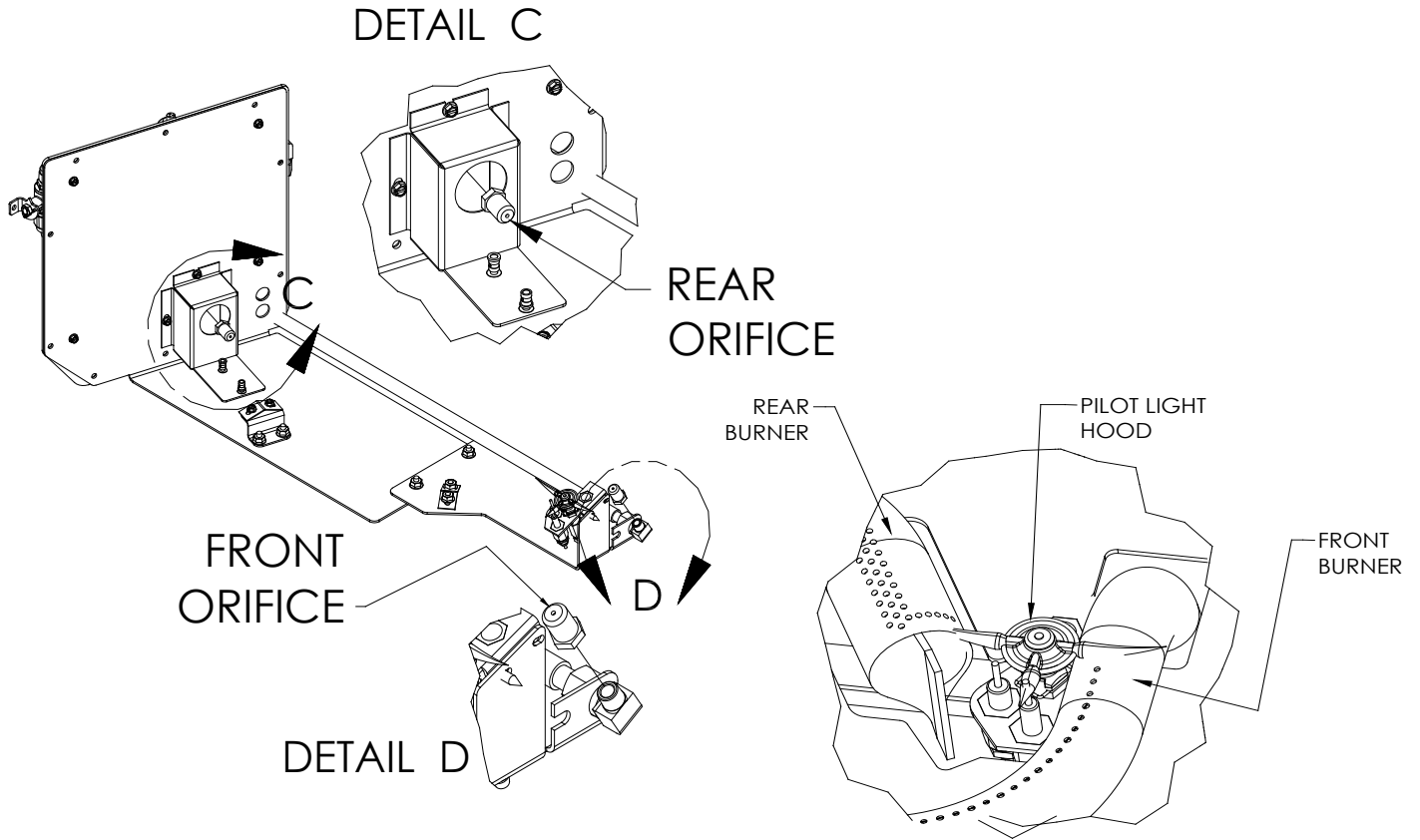

8. Locate Pilot Light on right side of firebox. While holding the pilot base body with large vice grips tightly, loosen Pilot Light's hex shape base using a 1/2" open end wrench. Rotate counter clock-wise 1/4 turn to loosen.
9. Pilot arrives from the factory set for NG. Push NG/LP Adjustment Clip inward all the way to set it for LP. See detail view, below. If you see "NAT" printing on the Adjustment Clip, this indicates that the pilot is set to burn NG. Push Clip in so that "NAT" is not visible.
10. Tighten down Hex shaped base of pilot using a 1/2" open end wrench.

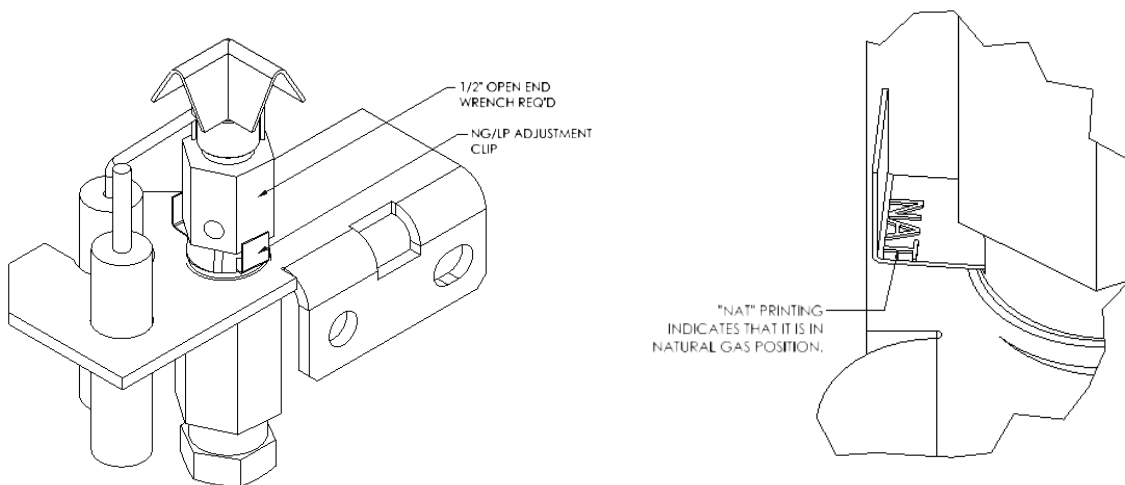

11. Before reinstalling burners, loosen the screw that secures the rotary air shutter on the Front Burner. Rotate the air shutter open to 1/4" minimum.

12. Install both rear and front burners in their original locations and positions and secure down using screws you removed earlier

13. Make certain front burner is running parallel to front face of unit positioned properly so that the pilot light hood pointing to the left is pointed properly towards the burner's flame propagation ports.

14. Make certain Rear Burner is positioned properly so that the pilot light hood pointing to the left is pointed properly to-wards the burner's flame propagation holes.

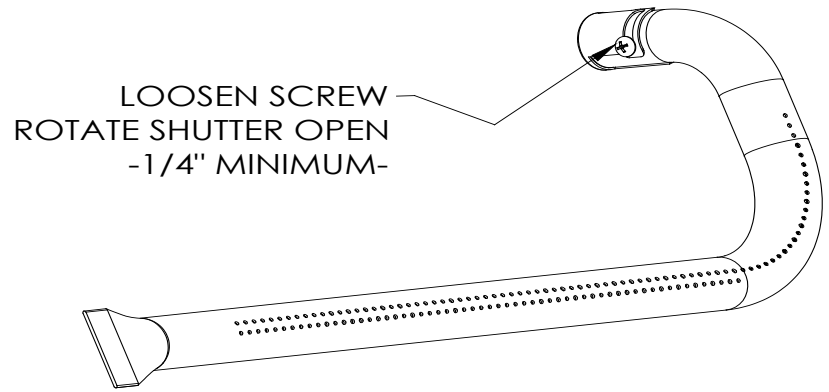

FRONT BURNER SHUTTER ADJUSTMENT

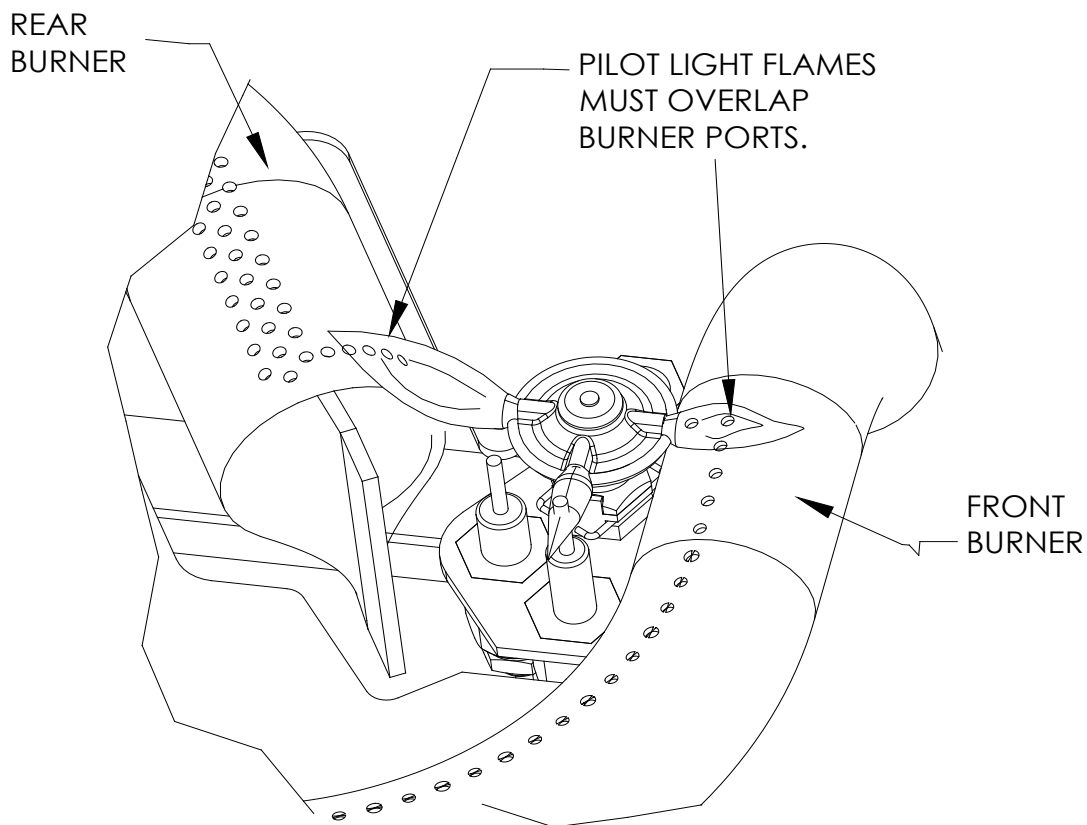

15. Remove the left-side access panel mounted to the left outer skin and lay down gently.

16. See diagrams on this page and identify the Pressure Regulator on the Valve Body.

17. Using a Torx T20 (supplied) or a slotted screwdriver, remove 2 screws that secure the NG Pressure Regulator to the gas valve body and remove NG Pressure Regulator, see following page for detailed instructions. Note: Be careful when removing or tightening the screw on the back-side of the pressure regulator. The screw location is difficult to access and care must be taken to ensure a proper seal when tightened.

18. Install the new LP Pressure Regular onto the gas valve body in the same position and orientation as the NG Pressure Regulator you removed in Step 17, above. The LP Pressure Regulator can only be mounted in one position. Secure the LP Pressure Regulator in place. Tighten down. See next page for specific details about changing the pressure regulator.

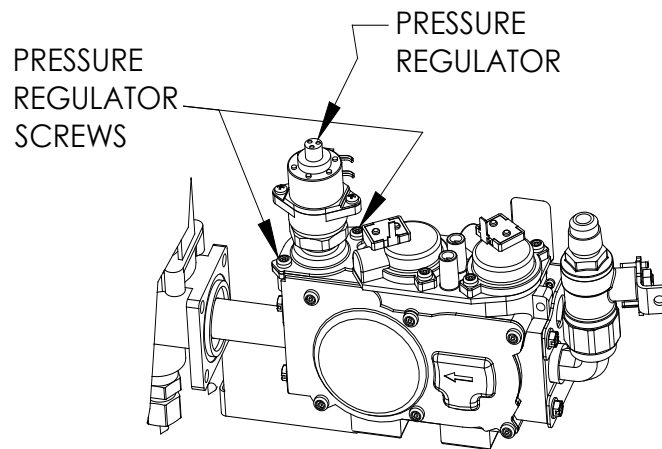
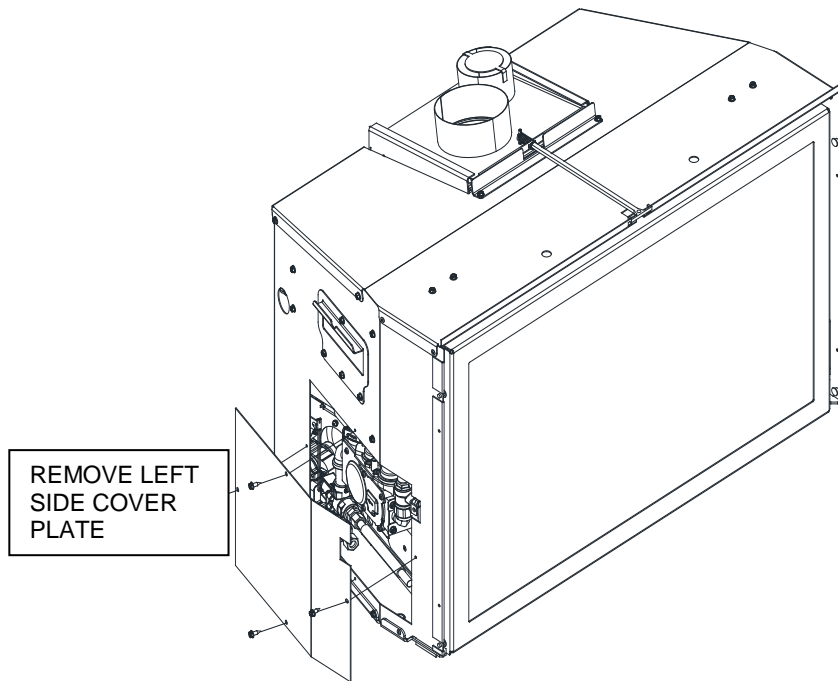

LP Pressure Regulator Conversion Instructions

WARNING: Failure to position the parts in accordance with these diagrams or failure to use only parts specifically approved with this appliance may result in property damage or personal injury.

WARNING!

The installation of this conversion kit must only be undertaken by a qualified and certified gas appliance installer.

STEPPER MOTOR PRESSURE REGULATOR CONVERSION KIT INSTALLATION OR REPLACEMENT INSTRUCTIONS.

Verify that the following items are present in the package.

- Pressure regulator assembly (E)
- Two (2) screws (F)
- Identification label (G)
- Installation instructions (this document).

- 1 Shut off the gas supply to the valve and shut down the electric supply.
- 2 See Fig. 1. Using a Torx T20, or slotted screwdriver, remove and discard the two (2) pressure regulator mounting screws (A), pressure regulator tower (B), and the spring and diaphragm assembly (C), (if applicable).
- 3 Ensure the rubber gasket (D), which is prefitted as part of assembly (E), is properly positioned, see Fig. 2, otherwise fit the gasket as shown Fig. 2.
- 4 Install the new STEPPER MOTOR pressure regulator assembly, as shown in Fig. 3 and Fig. 4. Use the supplied screws (F), M4 x 0.7 threaded, length of thread $L=(16\text{ mm} + 0 - 0.5\text{ mm})$, steel material, resistance class 8.8 (see Fig. 5).
- 5 Manually thread the two conversion kit mounting screws into the valve body. Use a standard screwdriver or T20 Torx bit and tighten to the screws with a fixing torque of $25\text{lb-in} \pm 5\%$.
IN THE EVENT THAT THE THREADS OF THE VALVE ARE STRIPPED OR DAMAGED, REPLACE THE VALVE.
- 6 Install the enclosed identification label (G) to the valve body where it can be easily seen.
- 7 Make STEPPER MOTOR and valve electrical connections, apply gas to system and relight appliance according to manufacturers instructions.
- 8 With the main burner "ON", test the new pressure regulator assembly for leaks using a soap solution.
- 9 Relight the main burner and verify proper burner ignition and operation.

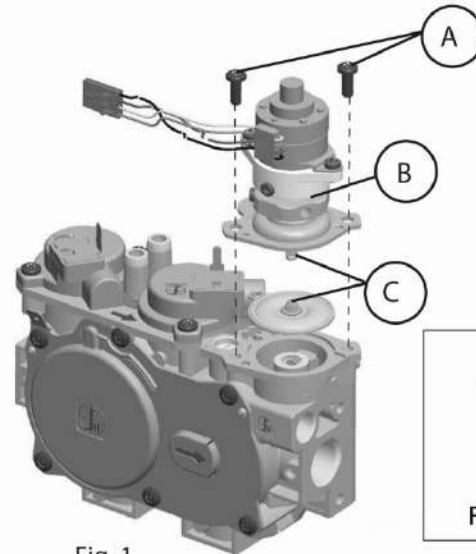

Fig. 1

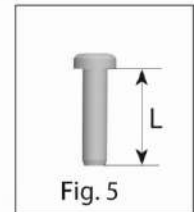

Fig. 5

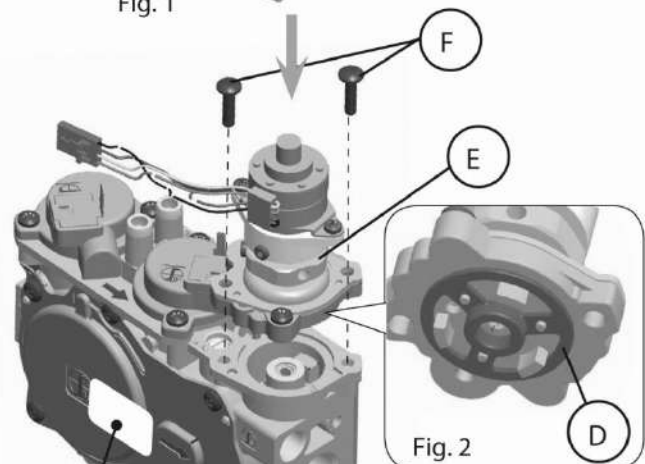

Fig. 3

Fig. 2

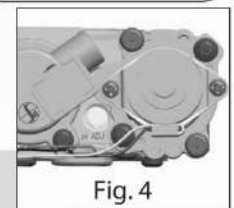

Fig. 4

WARNING!

Installation should be carried out in a clean environment.

WARNING!

This modulating conversion kit must ONLY be applied as part of a conversion kit supplied by the APPLIANCE MANUFACTURER for the specific appliance, and type of gas, being converted.

WARNING!

Correct operation of the system cannot be guaranteed if the conversion kit or valve has been dropped or has sustained a strong impact.

INSTALLER NOTICE. These instructions must be left with appliance.

Checking Burner(s) Ignition Characteristics

Once the conversion to LPG and all the above steps have been completed, light the main burners.

Use Remote Transmitter to turn on Pilot Light and burners. Main burner should now light IMMEDIATELY and flame should not "lift" off burner. If there is any delay in ignition or if flame is "lifting off" burner, turn off burner and carefully check for proper installation of logs/coals, vent system and proper pilot flame impingement on burner. Logs or coals must not block pilot flame or main burner flame. Vent system must be leak proof.

WARNING:

DO NOT PROCEED WITH OPERATION OF THIS FIREPLACE UNLESS BURNER "CYCLES" ON/OFF WITHOUT DELAYS!

Attaching LPG Conversion Labels

Two printed informational labels are included with the LPG Conversion Kit. Attach these two labels to the back surface of the Serial Number Plate that is located in the convection air cavity on the side the firebox. If you are de-rating this appliance at a high altitude, also attach the High Altitude De-Rating Label, supplied in the Owner's Manual Packet, to this same surface.

Prior to attaching the labels, fill in all the information that is requested in these labels.

LP Gas Pressure Requirements

Inlet and manifold gas pressure checking taps are located on gas valve. These ports are only accessible from the outer left side of the fireplace. A qualified installer shall take pressure measurements at these ports to verify and set the correct gas pressures during the LP Kit installation and before fascia materials are installed over the front of this fireplace. Manifold pressure must be taken at the "MANIFOLD PRESSURE" tap and inlet pressure at the "INLET PRESSURE" tap with the burner operating by a qualified installer.

	DESIRED INLET PRESSURE	MINIMUM INLET PRESSURE	MAXIMUM INLET PRESSURE	MANIFOLD OUTLET PRESSURE	AIR SHUTTER POSITION
L.P. GAS	11.0" W.C. (2.75 kPa)	11" W.C. (2.75 kPa)	13.0" W.C. (3.24 kPa)	10.0" W.C. (2.5 kPa)	1/4" OPEN MIN. (5 mm)

REGULATE THE FLAME HEIGHT TO "HIGH" POSITION. OUTLET GAS PRESSURES MAY VARY PLUS OR MINUS 5%.

LPG Proper Input Rates:

With the proper orifices installed, as specified above, this fireplace utilizing LP Gas will have a maximum input rate of 40,000 Btu/Hr.

Leak Testing Requirements

Prior to completing the conversion process, check for gas leaks with soap and water solution at all plumbing joints prior to placing this appliance into operation. It is recommended that all gas-plumbing joints, factory installed and field installed are checked for leaks.

Pilot Flame and Main Burner Relationship Verification

Prior to completing the conversion process, the qualified service technician must, light the pilot light and verify the relationship between the pilot light flames and the main burners. The pilot light flames directed towards the propagation ports on the rear and front burner must overlap the propagation ports on the burners. The pilot light flames must be a minimum of 3/4" long and must overlap the propagation ports on both the rear and front burners as shown in the diagram, below. Verify that the burner tubes ignite quickly and the burner flames propagate smoothly along the entire length of the burners.

Pilot Flame Length Adjustment

If the pilot light flame length is too short and the system does not maintain a standing pilot, a qualified installer may increase the length of the pilot light flames to meet the two requirements: Minimum pilot light length to maintain a standing pilot light and the pilot light flames must be long enough to overlap the front and rear burner ports.

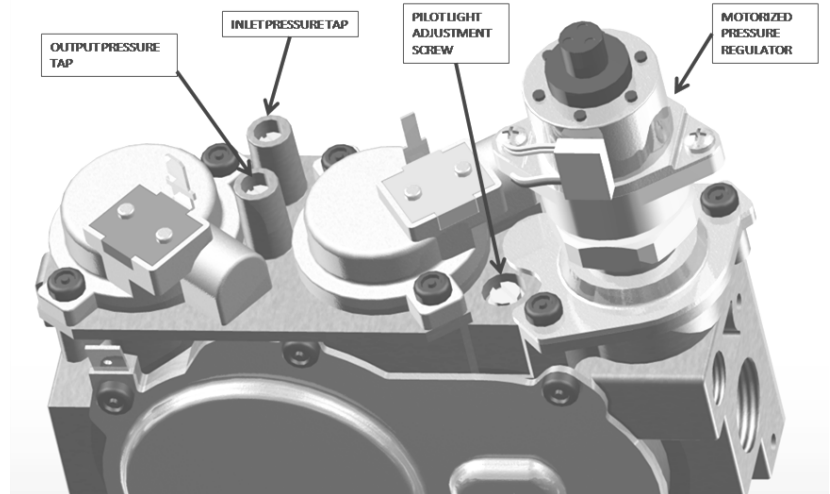
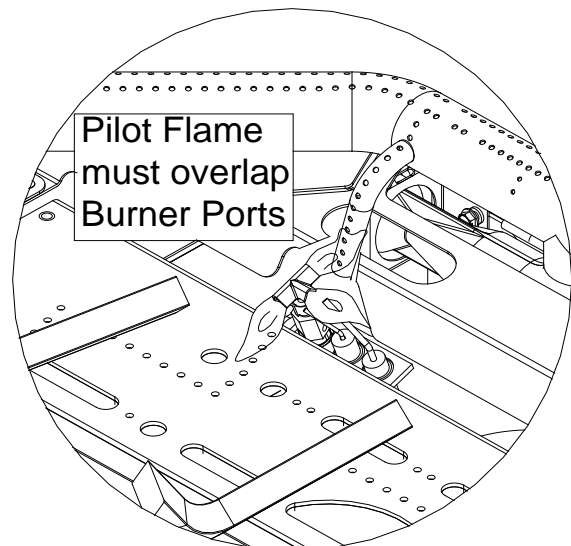
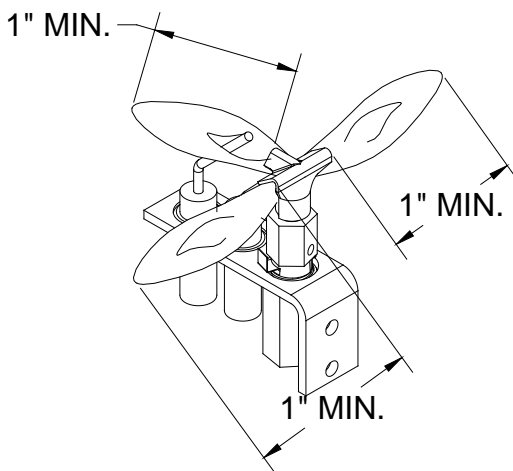

Figure 1: Pressure Test Port



LOG SET INSTALLATION

Other log sets in addition to the Premium Fiber Log Set, shown here, are available. Consult with dealer about options available. FOLLOW EACH STEP DEPICTED IN THE DIAGRAMS, BELOW, TO INSTALL THE LOG SET.

CAUTION: LOGS ARE FRAGILE, HANDLE LOG PIECES WITH CARE.

LOG SET PARTS IDENTIFICATION

(COALS AND INSWOOL BAGS ARE NOT SHOWN HERE)

 <p>LOG #1 : REAR LOG 35-01-00581</p>	 <p>LOG #2 : MID EMBER BED 35-01-00582</p>	 <p>LOG #3 : LEFT LOG 35-01-00608</p>
 <p>LOG #4 : RIGHT LOG 35-01-00580</p>	 <p>LOG #5 : LEFT TOP LOG 35-01-00579</p>	 <p>LOG #6 : RIGHT TOP LOG 35-01-00578</p>
 <p>LOG #7 : PILOT SHIELD LOG 35-01-00409</p>	 <p>LOG #8 : LEFT FRONT TWIG 35-01-00577</p>	 <p>LOG #9 : RIGHT FRONT CHUNK 35-01-00576</p>

PLACE LOG #1 (REAR LOG) ON REAR SHELF BEHIND REAR BURNER. SLIDE LOG TO RIGHT UNTIL LOG TOUCHES RIGHT SIDE BRICK PANEL. PUSH LOG BACK SO IT TOUCHES REAR BRICK PANEL. THIS LOG IS RECOMMENDED TO BE PUSHED TO THE FAR RIGHT SIDE.

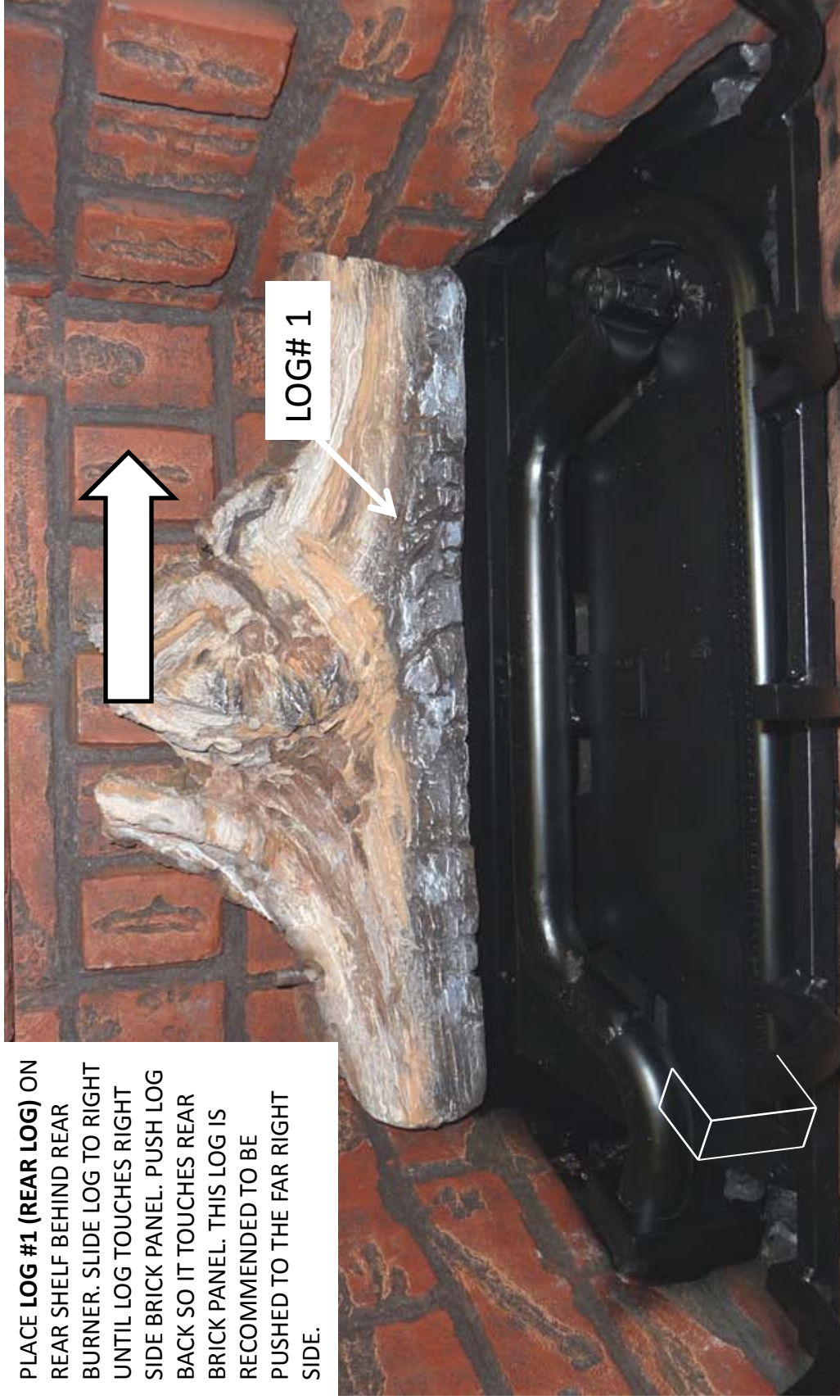

LOG #2 (MID EMBER BED) SITS BETWEEN REAR AND FRONT BURNER, FLAT DOWN ON THE SURFACE OF THE BURNER AIRBOX. ADJUST POSITION OF FRONT AND REAR BURNERS IF LOG #2 DOES NOT SIT BETWEEN REAR AND FRONT BURNER.

PLACE LOG #2 BETWEEN THE TWO BURNERS AND SLIDE TO THE RIGHT UNTIL THE CURVATURE IN THE FRONT BURNER CONTACTS THE CURVATURE ON THE RIGHT FRONT TIP OF LOG #2. PUSH LOG #2 DOWN TO INDENT THE BOTTOM WITH THE TWO BURNER MOUNTING SCREW HEADS. LOG #2 MUST NOT ROCK ON TOP OF THE SCREW HEADS. LOG #2 MUST BE STABLE.

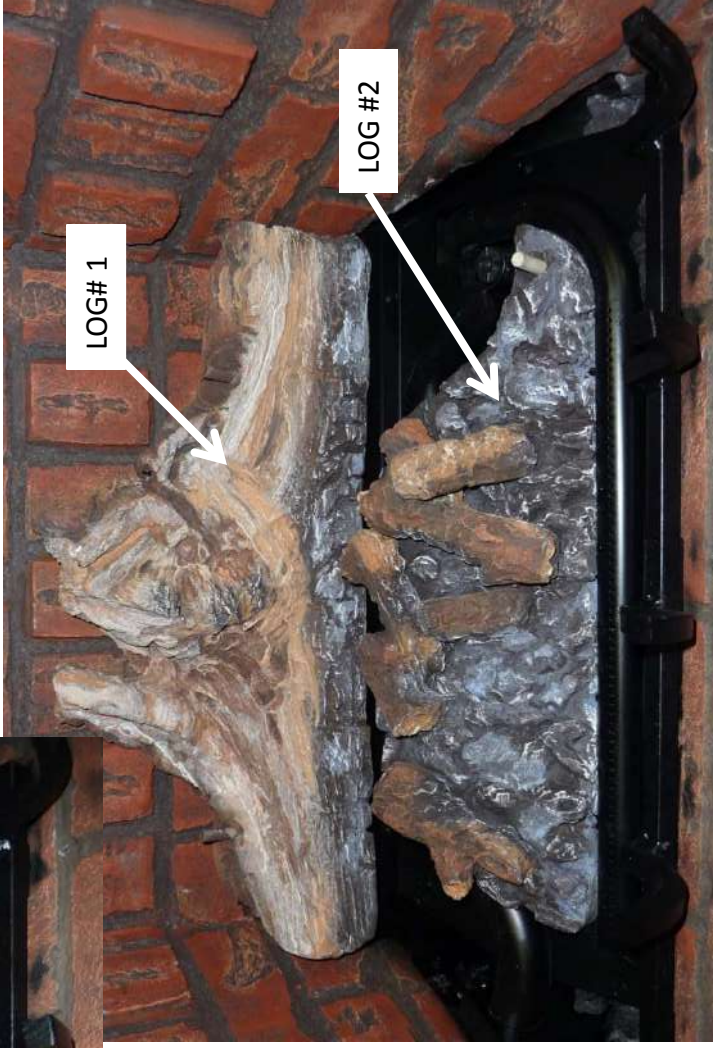

PLACE **LOG #3 (LEFT LOG)** ON TOP OF THE RECTANGLE AIR SHUTTER BOX ON THE LEFT SIDE. LOG #3 HAS A RECTANGULAR NOTCH ON ITS BOTTOM SIDE THAT ALLOWS THE LOG TO SIT SQUARELY ON TO OF THE BOX. ALSO, THERE IS A NOTCH THAT MATES WITH THE LEFT-MOST GRATE BAR. SET LOG #3 ON THE GRATE BAR AND THE RECTANGLE SHAPED AIR SHUTTER BOX TOP SURFACE.

LOG #3 MUST LEAVE CLEARANCE FOR THE REAR BURNER PORTS. SOME ROTATIONAL FLEXIBILITY IS ALLOWED FOR THE REAR END OF THIS LOG TO ROTATE TOWARDS LOG #2. HOWEVER, LOG #3 SHALL NEVER SIT ON TOP OF THE REAR BURNER PORTS. DOING SO WILL LEAD TO SOOT CREATION.

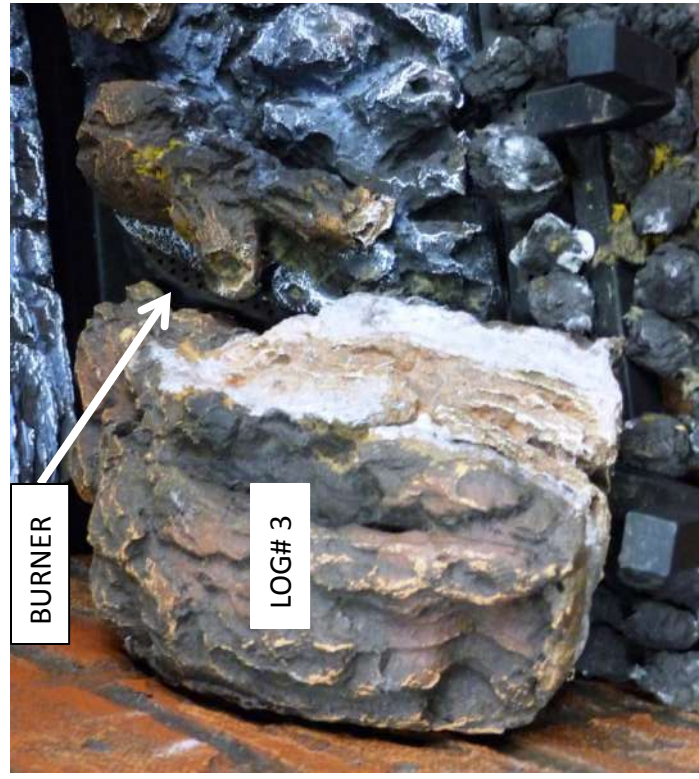
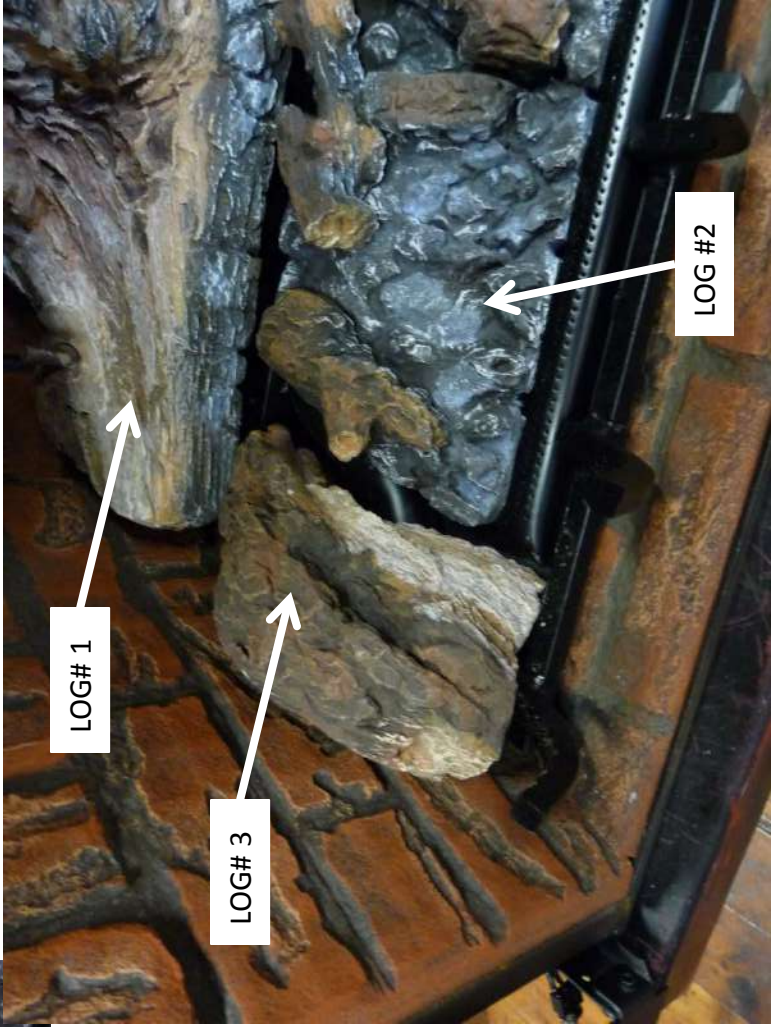
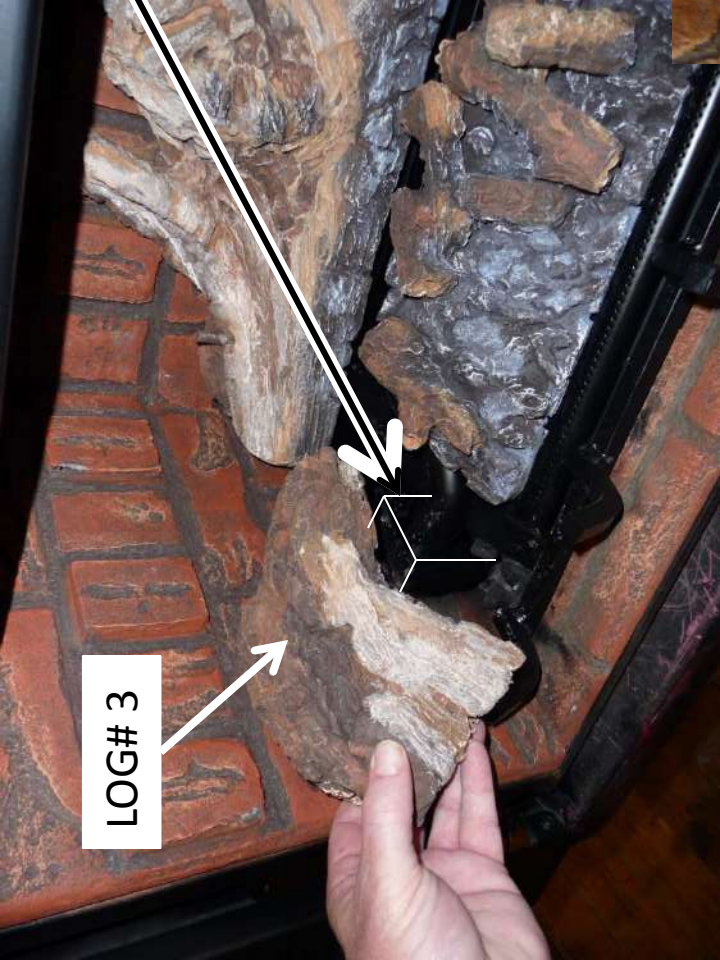

LOG #4 (RIGHT LOG) HAS A HOLE FOR THE PIN ON LOG #2.

INSERT PIN IN LOG #2 INTO HOLE IN LOG #4. SET RIGHT END OF LOG #4 ON TOP OF THE FIRST GRATE BAR ON THE FAR RIGHT SIDE.

SOME ROTATIONAL FLEXIBILITY IS ALLOWED TO LOG #4 AROUND THE PIN AND HOLE. HOWEVER, DO NOT ROTATE REAR END OF LOG OUTWARD. ROTATE INWARD ONLY IF DESIRED.

ROTATING OUTWARD MAY PLACE LOG #4 ON TOP OF REAR BURNER PORTS AND MAY LEAD TO SOOTING

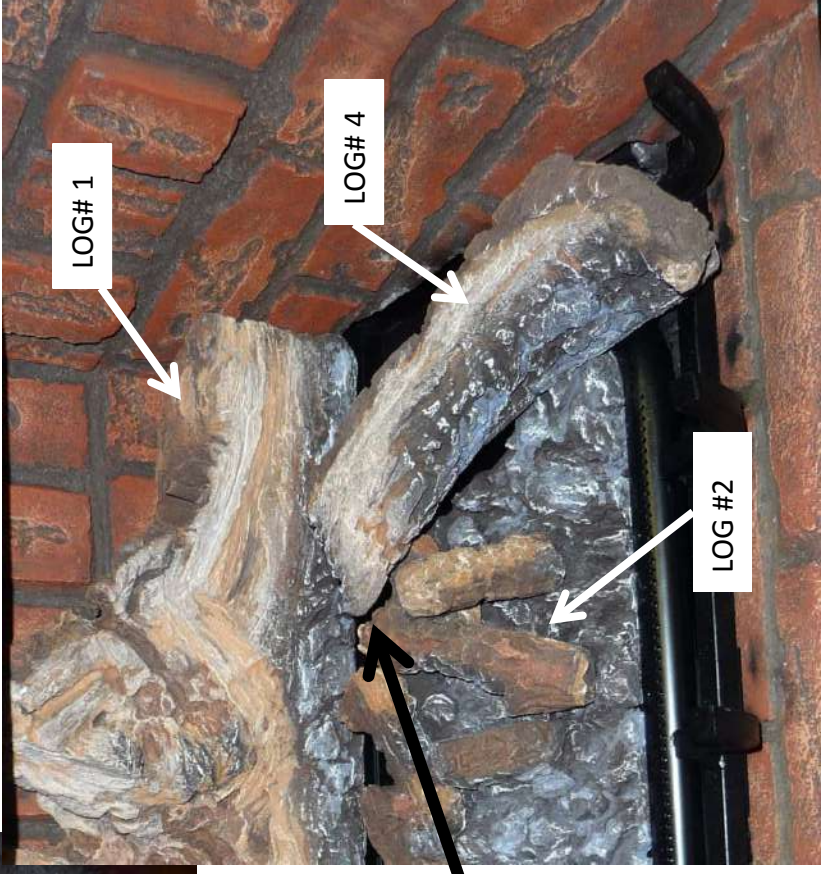

REAR TIP OF LOG #4 MUST SIT ON TOP OF LOG #2, HERE.

LOG #5 (LEFT TOP LOG) SITS ON THE LEFT SHOULDER OF LOG #1 AND ITS TWO BRANCHES SIT ON TOP OF LOG #2 AND LOG #3. LOG #5 HAS A HOLE THAT ALIGNS WITH THE LEFT SIDE PIN ON LOG #1.

THE V-NOTCH BETWEEN THE TWO BRANCHES MUST SIT DIRECTLY ON TOP OF THE REAR BURNER'S LEFT SIDE PORTS AND MUST ALLOW THE FLAMES TO RISE INTO THE V-NOTCH IN THIS LOG.

PUSH LOG #5 BACK SO ITS REAR END TOUCHES THE REAR BRICK PANEL.

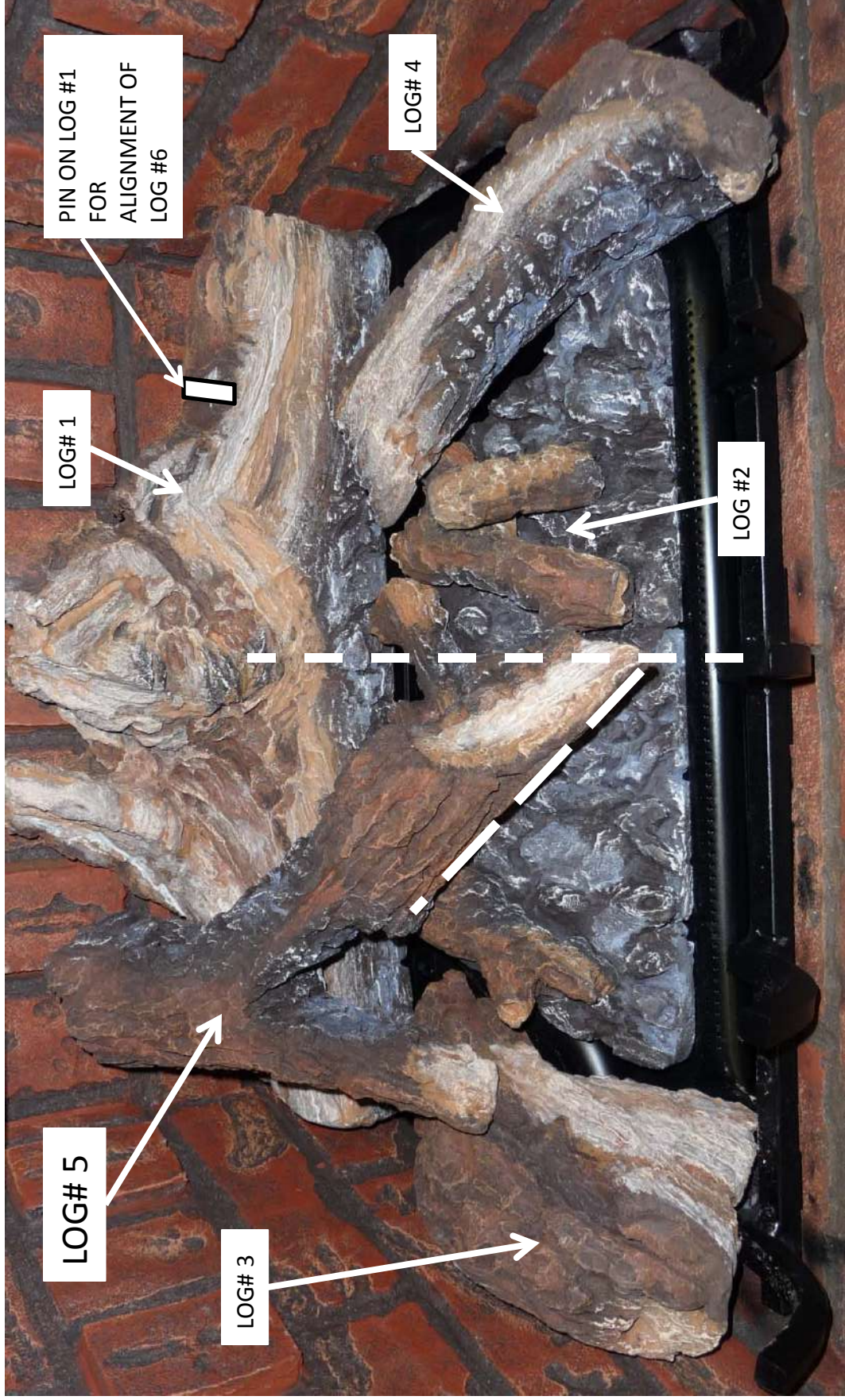

LOG# 5

LOG# 3

LOG# 1

**PIN ON LOG #1
FOR
ALIGNMENT OF
LOG #6**

LOG# 4

LOG #2

LOG #6 (RIGHT TOP LOG) SITS ON TOP OF LOG #1 USING THE PIN THAT IS ON THE RIGHT SIDE OF LOG #1. LOG #6 HAS A HOLE IN ITS BACK-SIDE TO MATE WITH THIS PIN.

PLACE LOG #6 ON TOP OF LOG #1'S PIN. THE OTHER END OF LOG #6 SITS ON TOP OF LOG #2 AS SHOWN, BELOW.

SOME ROTATIONAL FLEXIBILITY IS ALLOWED FOR LOG #6. THE POSITION OF LOG #4 WILL LIMIT THE ROTATION OF LOG #6.

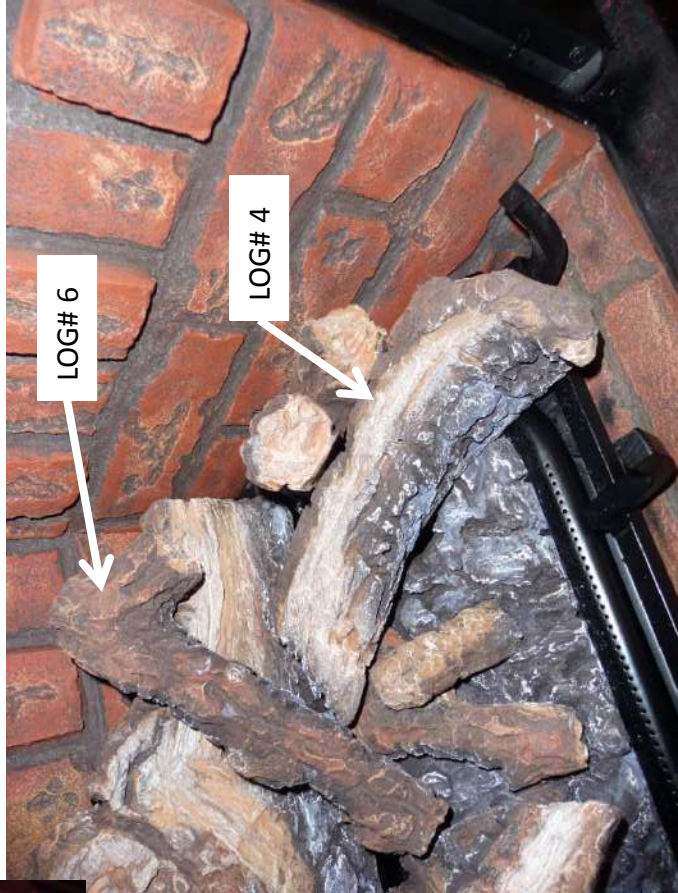
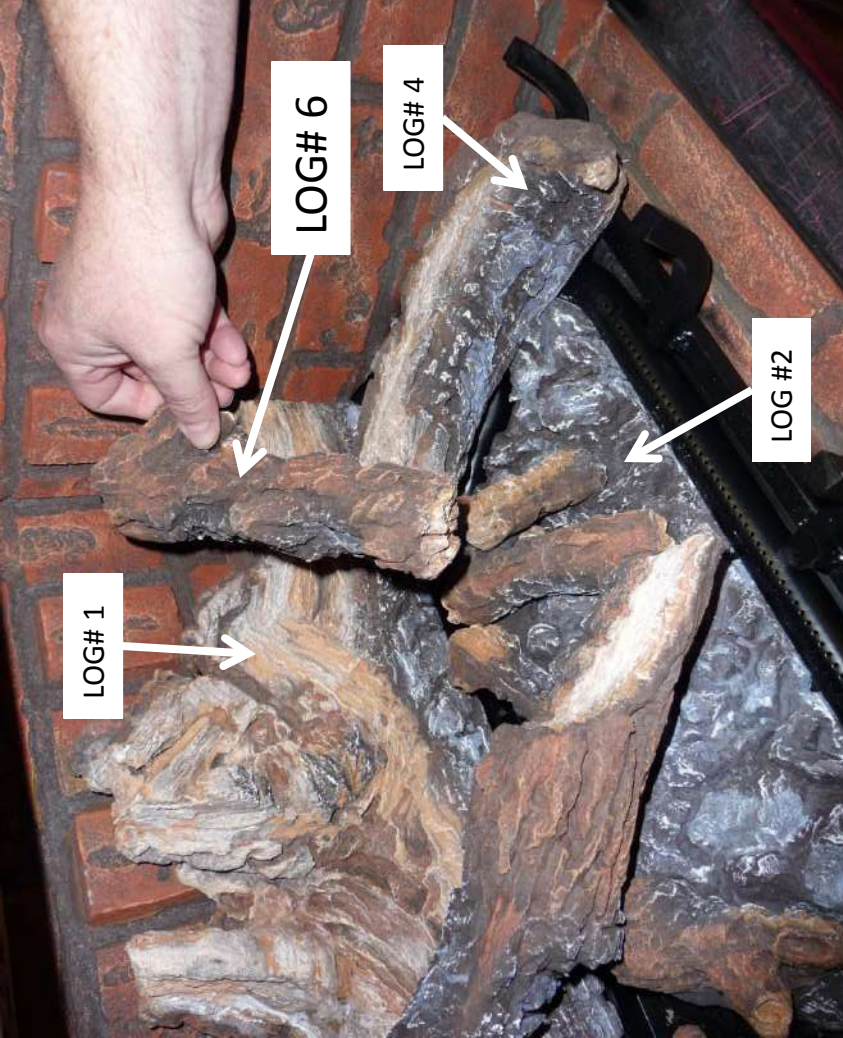

LOG #7 REST ON TOP OF THE FRONT BURNER'S REAR VISIBLE EDGE AND ON TOP OF LOG #4. THIS LOG IS DESIGNED TO HIDE THE PILOT LIGHT. PLACE THIS LOG SO IT PROVIDES CLEARANCE TO ALL BURNER FLAMES AND PILOT FLAMES, YET POSITIONED TO HIDE THE PILOT FLAMES.

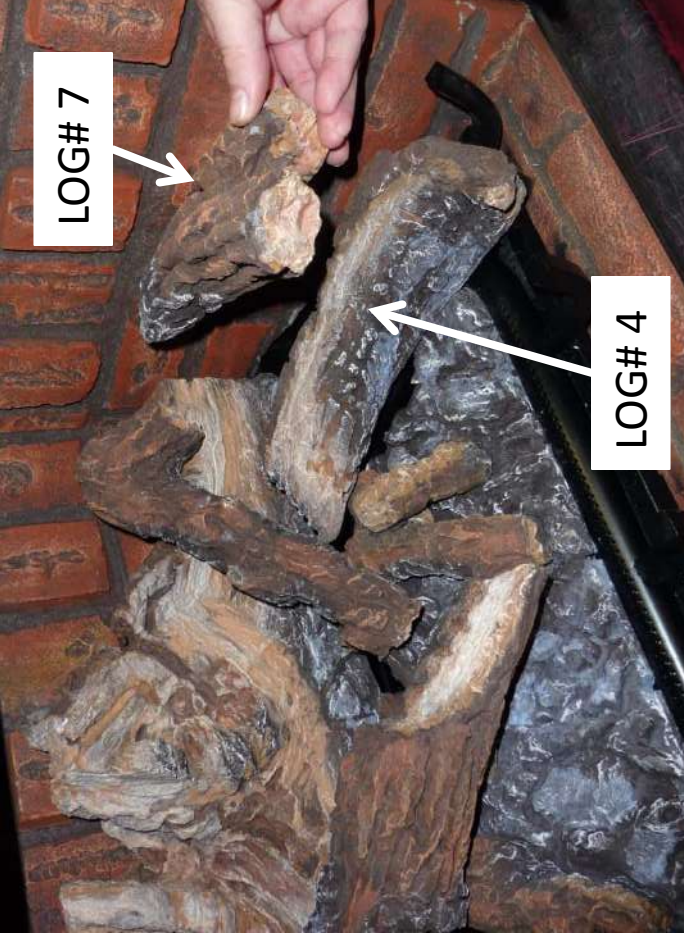
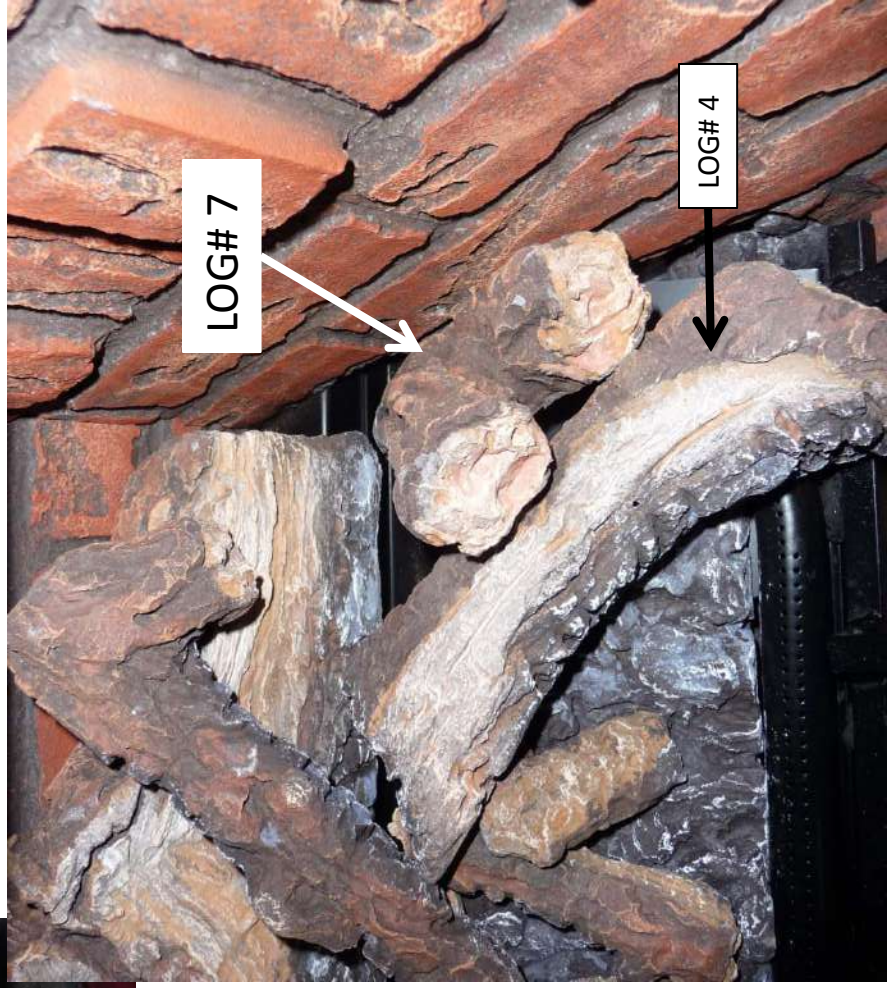
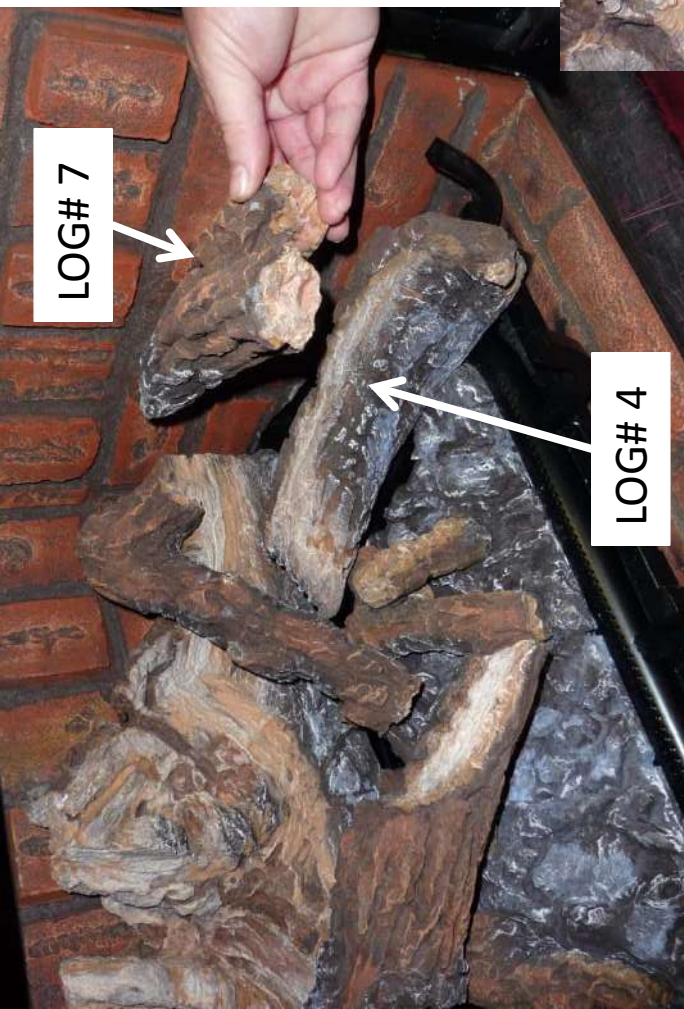

PLACE LOG #8 (LEFT FRONT TWIG) IN THE POSITION SHOWN HERE. LOG #8 SITS ON TOP OF LOG #2 AND RESTS AGAINST THE GRATE BAR (2ND FROM LEFT).

ATTEMPT TO POSITION LOG #8 AS SHOWN HERE FOR THE BEST GLOW EFFECT AND REALISTIC LOOK.

DO NOT PINCH FRONT BURNER PORTS WITH LOG #8.

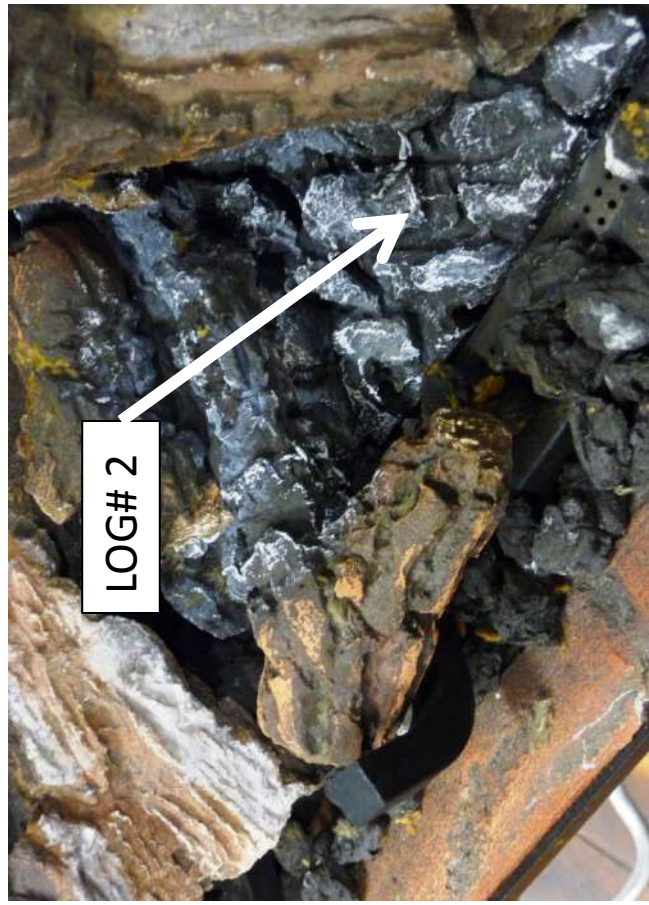
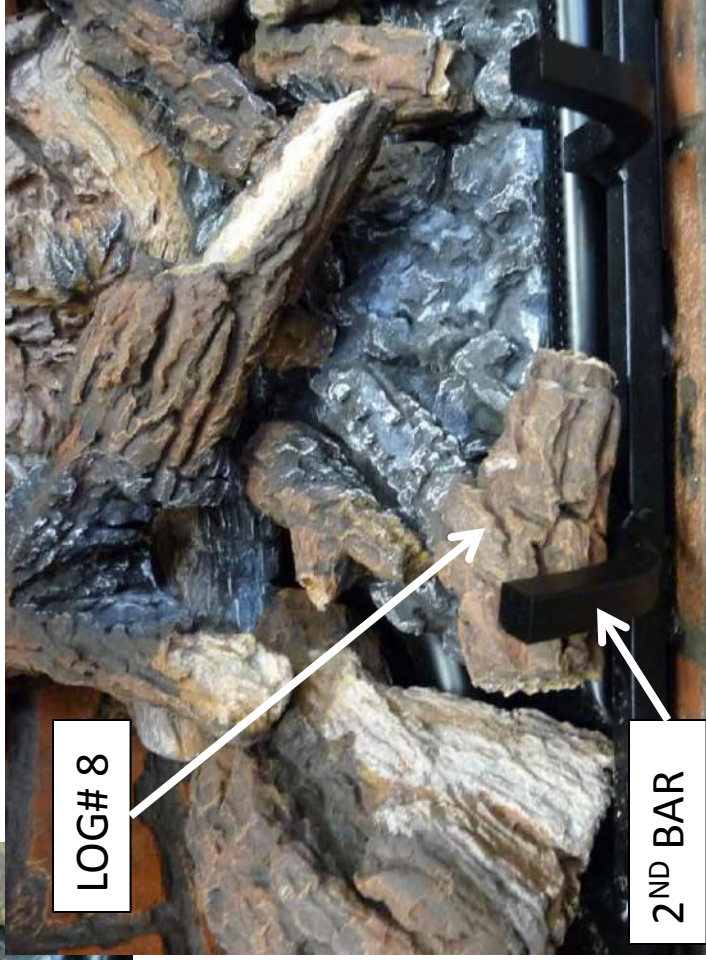
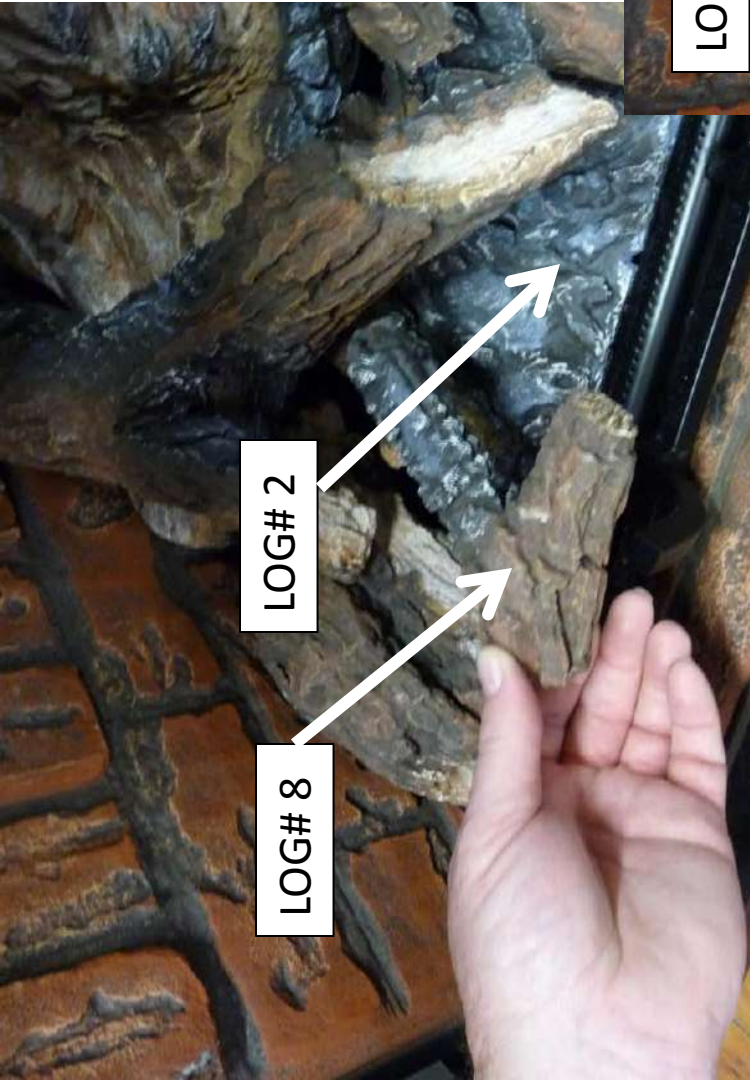



LOG# 9



LOG# 9

LOG #9 (RIGHT FRONT CHUNK) IS TO BE PLACED AT A SEVERE ANGLE AGAINST THE HORIZONTAL GRATE BAR AND FLOATING OVER THE FRONT BURNER PORTS. THE POSITION OF THIS LOG IS NOT CRITICAL. HOWEVER, DO NOT PLACE THIS LOG DIRECTLY ON TOP OF THE FRONT BURNER PORTS AND DO NOT PLACE THIS LOG ON TOP OF LOG #2.

SCATTER SMALL COALS ON THE FLOOR AND BETWEEN THE LOG GRATE'S HORIZONTAL BAR AND THE FRONT BURNER. A FEW COALS MAY SIT ON TOP OF THE FRONT BURNER TUBE BUT AVOID PLACING TOO MANY COALS ON TOP OF THE FRONT BURNER PORTS.

USING A TOOTH BRUSH, BRUSH INSWOOL (GLOWING EMBERS) RANDOMLY OVER LOG #2, THE COALS AND IN AREAS WHERE YOU WISH TO SEE GLOWING EMBER EFFECTS.



COMPLETED LOG SET ASSEMBLY

INSTALLATION CHECK OFF LIST

The following check list must be completed prior to initial lighting of the Fireplace Insert

- Venting system must be installed by a Mendota approved person with clamps and screws placed securely at all joints and all joints leak proof.
- Electrical supply and gas supply must be properly installed and must conform to National and Local Codes.
- Check that correct fuel supply is connected to appliance. Check correct gas pressure, correct size gas lines and for gas leaks on all gas supply connectors and this gas insert's gas valve train connectors.
- Proper clearances to combustibles must be maintained.
- LEAK TEST REQUIREMENT:** Vibration during shipping and transit of this appliance may cause some gas connections to loosen. All gas train connections in this appliance, including field installed supply line fittings and all factory installed gas train connections between the gas valve and the burner orifice(s) and pilot light, must be leak tested prior to first firing using soap and water solution or a calibrated Combustible Gas Detector. All leak tests are to be performed by a qualified installer. It is the responsibility of the installer to verify that all connections are sealed properly and leak-proof.

LIGHTING CHECK OFF LIST

Be sure to check these items before final operation of the Fireplace Insert

- All items on "Installation Check Off List" must be completed.
- Carefully follow all lighting and log installation instructions. Make certain that burner lights immediately and lights both front and rear burners.
- DO NOT proceed with operation unless burner cycles "on/off" without delays and the flame is "stable" and not "lifting" off burner.
- Caution: If pilot goes out be sure to wait a minimum of 5 minutes before relighting.

USING THE REMOTE CONTROL

BEFORE YOU BEGIN

Read this entire manual before you use your new fireplace insert (especially the section “Safety Precautions”). Failure to follow the instructions may result in property damage, bodily injury, or even death.

Remote Control Transmitter Functions

NOTE: The Wall Receiver will “beep” once every time a Remote Transmitter Key is pressed, signaling that the command has been received.

Identify the four function buttons on the Remote Transmitter:



Fig. 1: PROFLAME Transmitter.

1. **ON/OFF KEY:** This button turns the system ON or OFF. When this button is pressed and the system is OFF, the pilot light will stay ON if the “Standing Pilot Switch” is in the ON position. 

2. **THERMOSTAT KEY:** This button, when pressed after the ON/OFF KEY is pressed and the system is ON, will allow the selection of three modes: Manual Operation, Normal Thermostat and Smart Thermostat. 

- a. **Manual Mode:** In this mode, the room temperature is ignored and the fireplace can be turned ON indefinitely. The room temperature rise has no effect on this mode. All other functions such as fan speed control, flame height control, secondary burner On/OFF control and Accent Light ON/OFF controls will be manually controllable.

- b. **Normal Thermostat:** In this mode, the fireplace will stay functioning until the room temperature increases 1°F above the Set Point Temperature. To increase the Set Point Temperature, Press the UP button until the desired temperature is displayed in the SET POINT TEMPERATURE window. The fan will turn on 5 minutes after fireplace startup and will turn off 12-1/2 minutes after the flames turn off, in this mode. The flame height can be adjusted while the fireplace is functioning, fan speed can be adjusted after 5 minutes of startup. Secondary burner can be turned On or Off at any time after startup. The Accent Light can be turned on or off any time after startup.

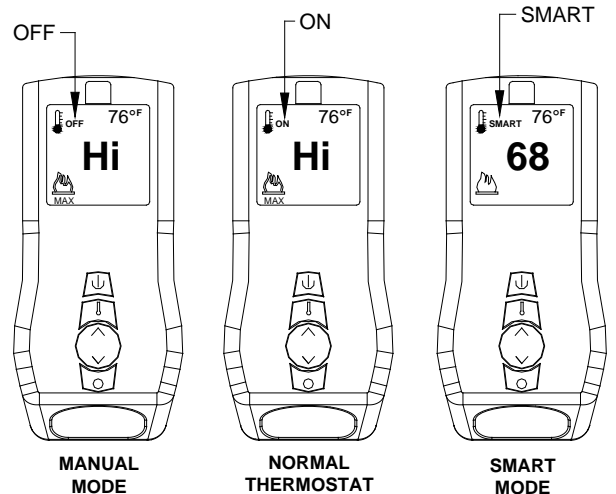

- c. **Smart Thermostat:** In this mode, all other functions except the flame height adjustment are allowed. Manual flame height adjustment is not allowed in this mode.

The Smart Thermostat function adjusts the flame height in accordance to the difference between the set point temperature and the actual room temperature. As the room temperature gets closer to the set point temperature, the Smart Function automatically modulates the flame down.

3. **UP/DOWN KEY:** This key is used to increase or decrease the Set Point Temperatures, Flame Height and Fan Speed and to toggle between Accent Light ON/OFF and Secondary Burner ON/OFF. 

MODE SELECTION KEY: This key is used to toggle between the various function icons: Set Temperature, Flame Height and Secondary Burner.

Setting Pilot to IPI versus CPI mode:

With the remote transmitter OFF, press the MODE button. You will see either “CPI” or “IPI” displayed on the transmitter screen. Press the UP arrow button to set “CPI” mode and press the DOWN arrow button to set “IPI” mode. One set to the desired setting, press On/Off button to activate the fireplace.

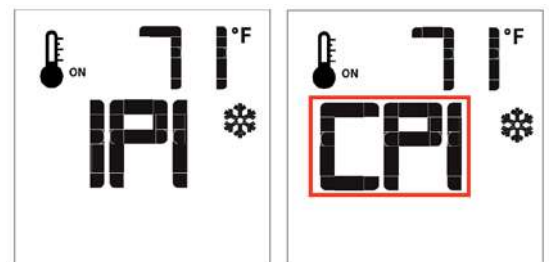

Remote Control Transmitter Operating Instructions

To Turn ON The Appliance

1. Press the ON/OFF button. The transmitter display will show all active icons on the screen.
2. Select the Thermostat Mode by pressing the Thermostat Key: OFF (meaning Manual Mode), ON (meaning normal Thermostat) or Smart (meaning Smart Mode).
 - a. In OFF (Manual Mode), the appliance will ignite and start on HI.
 - b. In ON (Normal Thermostat Mode), the appliance will only ignite if the Set Temperature is greater than the Room Temperature.
 - c. In SMART (Smart Mode), the appliance will only ignite if the Set Temperature is greater than the Room Temperature.

To Turn OFF The Appliance

Press the ON/OFF button.

Remote Functions



Mode Key: Pressing the MODE KEY toggles between the various available functions: Flame Height, Fan Speed, Accent Light Dimmer and Secondary Burner On/Off.



FLAME HEIGHT

Flame Height: 6 flame height Levels are available. While the Flame Height Icon is displayed, pressing the Up or Down button once will increase or decrease the flame height by 1 of 6 increments. If the flame height is at Level 1 and the Down button is pressed, all burners will turn OFF. If in IPI mode, the pilot light will also extinguish. If in Standing Pilot Mode, the pilot light will remain ON. Note: If in SMART model, the flame height function is not available for manual adjustment. In SMART mode, the flame height regulates automatically.



Flame Off

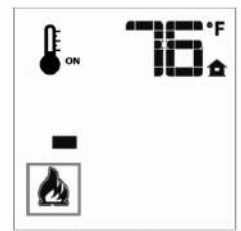

Flame Level 1

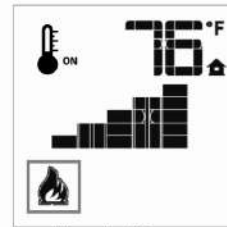

Flame level 5

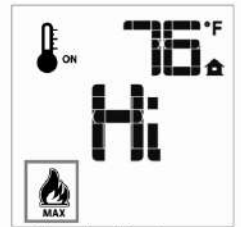

Flame Level Maximum



FAN SPEED

Fan Speed Control: The fan speed can be adjusted through six (6) speeds and OFF. To activate this function, press the MODE Key to index to the fan control icon. Use the UP/Down Arrow Key to turn ON, OFF or adjust the fan speed. A single “beep” will confirm reception of the command. Once you set the desired fan control, the system will remember your selected fan speed until you manually change it.

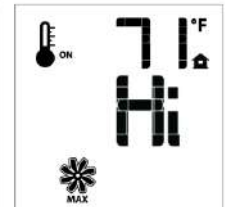
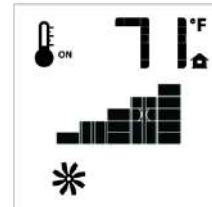

Accent-Light Dimmer: This function controls the Mendota Accent Light functions. Pressing the UP key in this mode will TURN ON the Accent Light and allow you to control the brightness of the Accent Light in 6 steps. A single “beep” will confirm reception of the command. Once you set the desired light brightness, the system will remember your selected brightness level until you manually change it.



2nd BURNER

Secondary Burner: This function controls the Secondary Burner's ON/OFF feature. Pressing the UP Key in this mode will TURN ON the Secondary Burner and Pressing the DOWN Key will TURN OFF the Secondary Burner. The flame level will not change when you turn the Secondary Burner On or Off. The flame level can only be changed in the Flame Level mode.

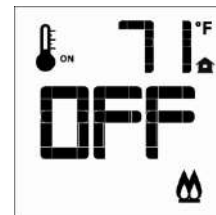

NOTE: The “AUX” function is not available and shall be skipped over.

TEMPERATURE INDICATOR (°F or °C)

1. Press the ON/OFF Key and Turn Off the Fireplace.
2. Simultaneously, Press both the MODE Key and the Thermostat Key.
3. Look at the LCD display to verify that your desired indicator (°F or °C) is being displayed. If not, repeat step 2.

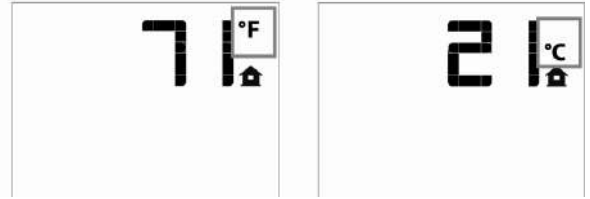

KEY LOCK FUNCTION

To prevent unsupervised children from operating the fireplace, a KEY LOCK function is provided with this remote control system. To activate the KEY LOCK function, simultaneously press the "MODE KEY" and the "UP KEY". To deactivate the KEY LOCK function, simultaneously press the "MODE KEY" and the "UP KEY".

During KEY LOCK mode, none of the Keys will function. You must DEACTIVATE the system before you can use the Remote Transmitter.



LOW BATTERY POWER DETECTION

1. **Transmitter Batteries:** The life span of the remote control transmitter batteries depends on various factors: quality of the batteries used the number of ignitions of the appliance, the number of changes to the room thermostat set point, etc. When the Transmitter batteries are low, a Battery Icon will appear on the LCD display of the Transmitter before all battery power is lost. When the batteries are replaced, this icon will disappear.

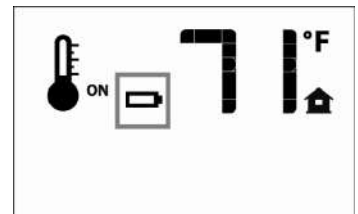

2. **Wall Receiver Batteries:** The life span of the wall receiver batteries depend on the quality of the batteries used and how long the batteries have been installed in the wall receiver. These batteries are only utilized during power outages. Replace these batteries every heating season even if you have not experienced any power outages. Batteries drain slowly even when not in use. This is a normal characteristic of all batteries.

INITIALIZING THE REMOTE CONTROL SYSTEM

MASTER SWITCH: Remote Transmitter WILL NOT communicate to receiver unless the Master Switch is ON. The master switch when OFF disables all functions and acts as a Master Safety Shutoff Switch.

Synchronizing the Receiver and Transmitter

Master Switch and Sync Switch are located on the bottom left corner of the appliance.

1. Toggle Master Switch to ON (toggle UP). Remote Transmitter WILL NOT communicate to receiver unless the Master Switch is ON.
2. Locate Sync Switch (below Master Switch). Press the Sync Button and release. The receiver will beep 3 times indicating that it is ready to synchronize with a Remote Transmitter.
3. Push the "ON" key on the Remote Transmitter. The receiver will beep 4 times to indicate that the Transmitter's command is accepted and sets to the particular code of that Transmitter. The system is now initialized.

NOTE: Once synchronized, the Transmitter and Receivers will communicate permanently and no further Synchronizing steps are necessary unless either the Transmitter or Receiver is replaced.

FIRST TIME LIGHTING INSTRUCTIONS

FOR YOUR SAFETY READ BEFORE LIGHTING

WARNING: If you do not follow these instructions exactly, a fire or explosion may result causing property damage, personal injury, and loss of life.

Safety Information

- This appliance is equipped with an ignition device which automatically lights the pilot. Do not attempt to light pilot by hand.
- **BEFORE OPERATING**, smell all around appliance area for gas. Be sure to smell next to the floor because some gas is heavier than air and will settle on the floor.
- Toggle Master Switch to **ON**. Remote Transmitter will not communicate to receiver unless the Master Switch is **ON**.
- Use only the supplied remote control to light the pilot. This valve will not operate if the pilot is not lit and stable.
- Do not use this appliance if any part has been underwater. Immediately call a qualified service technician to inspect and replace any component which has been under water. Attempted operation may result in fire or explosion resulting in property damage, personal injury, and loss of life.

WHAT TO DO IF YOU SMELL GAS

- **Do not light any appliance.**
- **Do not touch any light switch**
- **Do not use any phone in your building.**
- **Call your gas supplier from a neighbor's phone.**
- **Follow the provider representative's instructions.**
- **If you cannot reach your gas supplier, call the fire department for assistance.**

Operating Instructions

1. Stop! Read the above safety information carefully before proceeding!
2. Do not attempt to light the pilot by hand; the door must remain on this unit during pilot ignition, except for the "First Time Lighting".
3. Press the ON/OFF Key on remote control to begin the ignition sequence.
4. The wall receiver will emit an audible "beep"; after which the igniter will begin to spark. After the pilot lights and is established, the valve will automatically open and the burner will light. The burner will initially light to full flame. Adjust it to an appealing setting with the remote. See Remote Operating Instructions in Operating Instructions Manual.
5. **WARNING!** If the pilot fails to light the system will "lockout". Press ON/OFF Key on remote control to Turn Off the system. Allow five (5) minutes for any gas in the unit to dissipate before attempting to re-light the pilot. **SEE STEP "B" ABOVE.**
6. Press ON/OFF Key on remote control again to start ignition sequence.
7. If the appliance will not operate, follow the instructions "To Turn Off Gas To Appliance" and call your service technician or gas supplier.

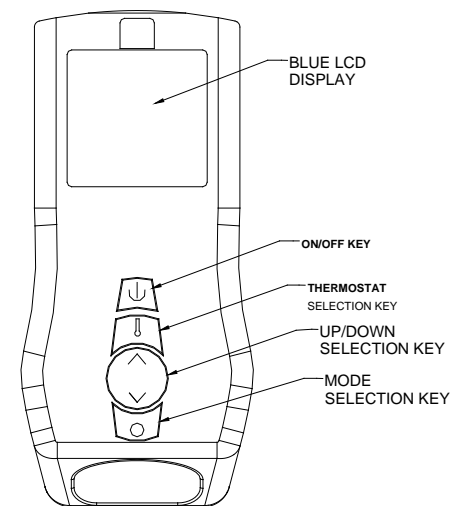

REMOTE TRANSMITTER

To Turn Off Gas to Appliance

1. Press the ON/OFF button on the Remote Control Unit.
2. Turn OFF the External Manual Shutoff Valve supplied by installer and mounted adjacent to appliance.
3. To access the Gas Valve reference "Accessing the Gas Valve" section in the Owner's Manual.
4. Turn OFF all electric power to the appliance if service is to be performed.

FLAME APPEARANCE ADJUSTMENT

During the initial installation, the air shutter opening should be checked to be certain that the shutter is set correctly at 1/8" to 1/4" open for natural gas and 1/4" minimum open for L.P. gas. NOTE: For altitudes above 5,000 ft., some variations may be required.

Be sure burner and logs are properly installed. After burner has been properly installed and operated for 2-3 hours, small additional adjustments to the air shutter may be necessary for final flame appearance. These small shutter adjustments can be made by the following procedure:

NOTE: Very small changes in shutter settings make major changes in flame appearance.

1. Air shutter control for the rear burner is located on the right side of the unit, behind facings or door, next to the glass door frame.
2. If flame is too "blue," push air shutter in (close) in small 1/8" increments until flame turns desired realistic "orange." Use glass latch tool to hook cable end and push/pull.
3. If flame is too "orange" or is causing soot on viewing glass, pull air shutter out (open) in approx. 1/8" increments until soot stops. IF SOOT DOES NOT STOP, TURN OFF UNIT AND CALL YOUR MENDOTA SERVICE PERSON.

IMPORTANT: Try each new shutter setting approx. 1/2 hr. before making additional changes. NOTE: Changes in front burner flame can be made by re-arranging the coals and front burner air shutter opening. (See above.)

NOTICE: It is recommended that you run this Fireplace on maximum flame height with the Convection Blowers turned on at level 2 or level 3 for the first 1-1/2 hours. After the first 1-1/2 hours, turn OFF the Convection blowers and proceed burning on high fire for 1 cycle of 2 hours ON and 2 hours OFF to cure the paint and expel any burn off odors. Expect some visible smoke and smell during the curing cycle. Open all door and windows during initial cure cycle.

WARNING: Label all wires prior to disconnection when servicing controls. Wiring errors can cause improper and dangerous operation. Verify proper operation after servicing.

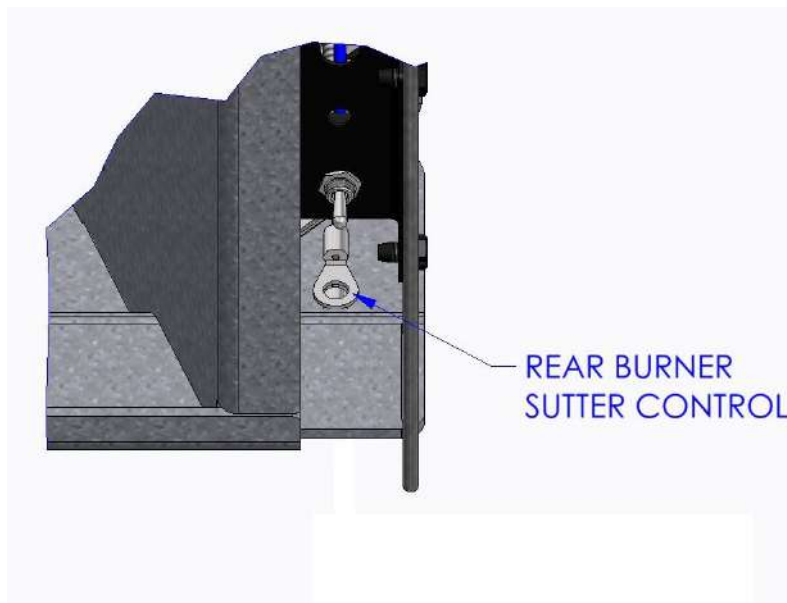

TROUBLE-SHOOTING

Common Trouble-Shooting Information

Over Firing or Under Firing of Burner

NEVER "over fire" units by adjusting gas pressure to increase BTUH above nameplate specifications. Over firing can cause permanent damage to firebox and deterioration of parts and void warranty.

Pilot Outage and Re-Lighting

If pilot goes out, be sure to wait a minimum of five minutes before attempting to re-light the pilot.

Cleaning Viewing Glass

The viewing glass should be cleaned periodically. Exterior glass may be cleaned with cleaner as desired. For Interior glass, use soap and water. NEVER USE ABRASIVE CLEANERS, NEVER CLEAN GLASS WHILE OPERATING, OR WHEN GLASS IS HOT.

NOTE: Additives that are put in gas (both natural and propane) to make it smell can be harmful to glass and can leave a white film deposit on the glass. This deposit can be removed with cleaners such as KEL KEM "Polish Plus" (# 65-06-00455, See your dealer for availability).

In some cases (especially propane) additives can cause "crazing" or etching on the glass. Although this is not normal, it is not covered under the warranty. The solution may be to change propane suppliers.

Sooting is caused by improper installation or operation. At the first sign of "sooting" (usually a thin black film on the Fireplace viewing glass) the unit must be immediately turned off and the local Mendota dealer promptly informed. Mendota products are designed and tested to operate without producing any "sooting" when installed and operated correctly. Mendota dealers will correct "sooting" problems, but Mendota and their dealers are not responsible for damage caused by excessive sooting that has not been immediately brought to their attention.

Trouble-Shooting Mendota Gas Inserts

SYMPTOM	PROBABLE CAUSES	CORRECTIVE ACTION
1. Thin black coating [soot] forms on viewing glass.	A. Incorrect gas pressure B. Not enough combustion air	Have gas supplier check for correct gas pressure [7" W.C. Nat. Gas; 11" W.C. LP Gas]. If sooting continues open-air shutter on burner [see "Gas Flame Adjustment" below]. If sooting still continues, call a Mendota dealer. NOTE: To clean glass - remove glass and wipe glass with cloth or paper towel.
2. Humming or whistling coming from Fireplace Insert.	A. Normal operating noise.	Some noise is normal. It is caused by the gas supply flowing through the gas orifice. It is expected from any gas fireplace. The noise can be reduced by turning the Hi/Lo Knob on the control. Turning down the flame will reduce the heat output of the Insert.
3. A change in flame appearance or burner operation.	A. A change in gas pressure. B. Carbon dirt or lint.	Have your gas supplier check for correct gas 7" W.C. Nat. Gas; 11" W.C. LP Gas]. If flame still needs adjustment see "Flame Adjustment" below. Clean out carbon, spider webs, lint, etc. from shutter area. NEVER BLOCK AIR INTAKE OR OUTLET VENTS.

MAINTENANCE

Required Annual Maintenance

The following procedures must be performed each year by a Mendota approved service person.

NOTE: Any adjustments to burner, pilot or logs must be done by a qualified Mendota service person.

1. Clean all lint and dust build-up around the control. Inspect the condition of any wiring under the burner for melting or damage. Clean flame sensor rod/hook using emery cloth. Vacuum all burner ports and pilot assembly.
2. Remove logs & coals and clean away any foreign matter (lint, Carbon, etc.) on the burner and logs. Be sure the burner ports are "open". Clean the pilot and under side of the logs for any Carbon deposits. NOTE: Logs should be visually checked for Carbon "build-up". If carbon deposits are visible on logs, unit should be turned off and Mendota service person contacted. Be sure logs are re-installed per instructions.
3. Check condition of glass door gasket, gasket must seal tightly over firebox, Inspect gasket along top and sides of glass. If gasket at corners of glass are bulging outward or if gasket bulb along top edge or sides are discolored to a white color appearance through the whole thickness of the gasket bulb, then replace the gasket. White colored gasket bulb indicates exhaust leak through the discolored area and requires replacement of the glass gasket.

Periodic Inspections Required

1. Check to verify that the vent system and vent cap are open and free of blockage.
2. Before re-installing glass, have qualified service person check the operation of the pilot and cycle the burner per LIGHTING INSTRUCTIONS (see Owner's Manual). Be sure all items in LIGHTING and INSTALLATION "check off" lists are completed.
3. The viewing glass should be cleaned periodically. Exterior glass surface may be cleaned with cleaner as desired. To clean Interior glass surface, use Kel Kem "polish plus" (part # 65-06-00455) or comparable product. Do not use oven cleaner or abrasive cleaners to clean glass. Do not clean when glass is hot.
4. Periodic visual check of pilot flames is required. Pilot Flame must overlap Flame Sensor and burner ignition ports at all times. Especially for LPG applications, always verify visible pilot flame length is at least 1" long.
5. Periodic visual check of main burner's rear and front flames is required.

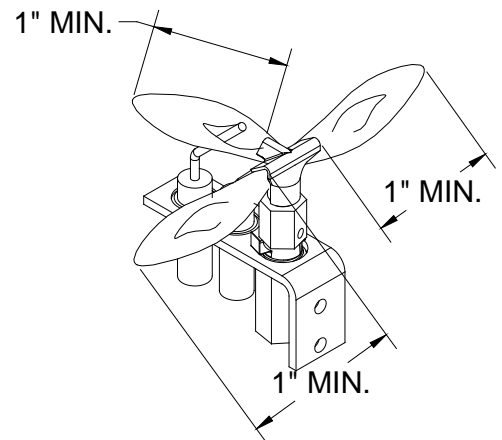

Burner Flames General Heights Reference Diagram



WIRING DIAGRAM

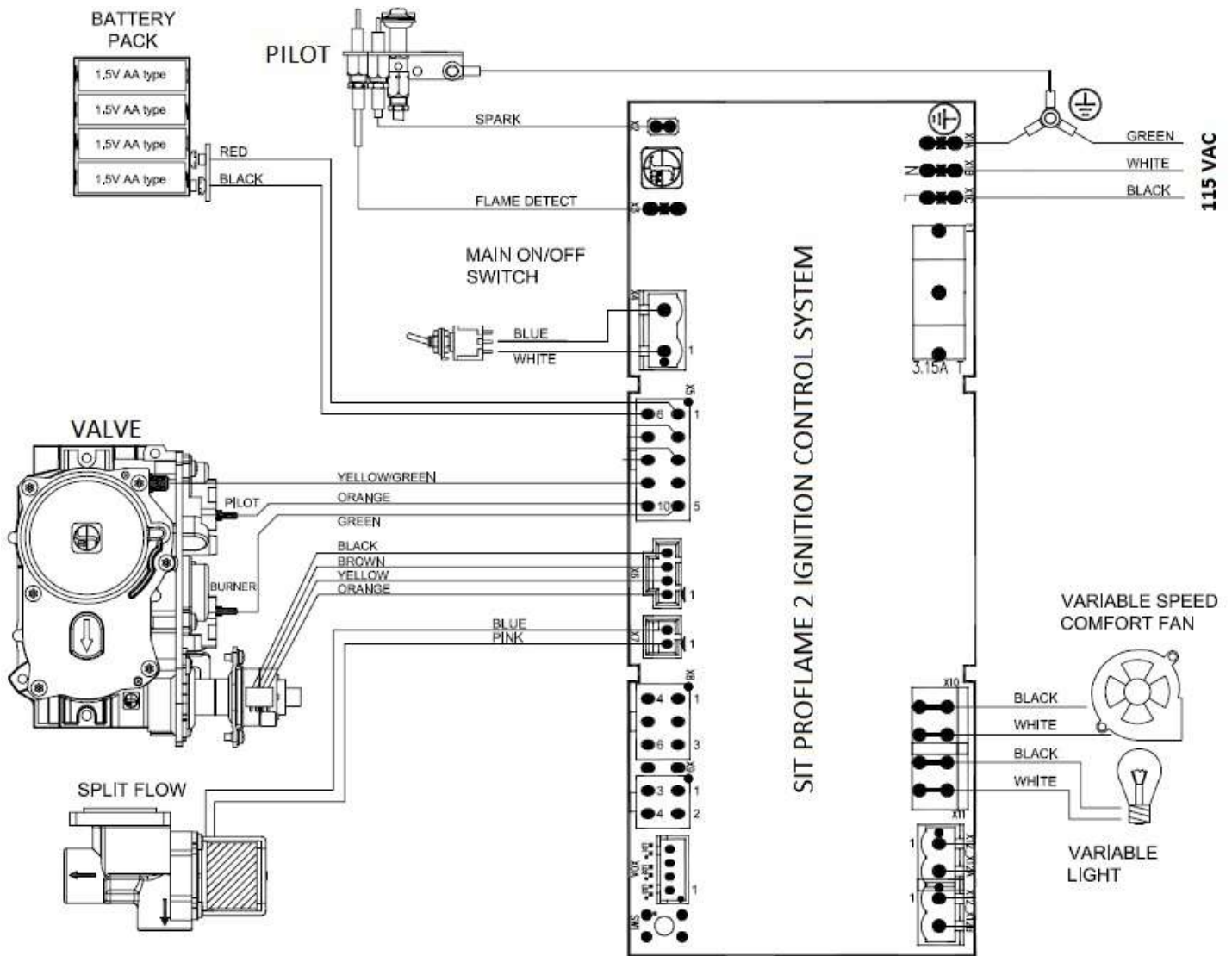

NOTES:

-CONNECT WIRES IN JUNCTION BOX ON THE LEFT SIDE OF THE FIREPLACE TO HOUSE POWER USING THE SUPPLIED WIRE NUTS.

-REPLACEMENT WIRE MUST BE OF THE SAME SIZE AND TYPE OF INSULATION AS ORIGINAL.

-THE APPLIANCE MUST BE ELECTRICALLY CONNECTED AND GROUNDED IN ACCORDANCE WITH LOCAL CODES OR, IN THE ABSENCE OF LOCAL CODES, WITH THE CURRENT NFPA 70-NATIONAL ELECTRIC CODE OR CSA C22.1-CANADIAN ELECTRICAL CODE.

-LABEL ALL WIRES PRIOR TO DISCONNECTION WHEN SERVICING CONTROLS. WIRING ERRORS CAN CAUSE IMPROPER AND DANGEROUS OPERATION. VERIFY PROPER OPERATION AFTER SERVICING.

65-01-00457

The appliance must be electrically connected and grounded in accordance with local codes or, in the absence of local codes, with the current NFPA 70-National Electric Code or CSA C22.1-Canadian Electrical Code.

Caution: Label all wires prior to disconnection when servicing controls. Wiring errors can cause improper and dangerous operation" and "Verify proper operation after servicing."

Attention: Au moment de l'entretien des commandes, étiquetez tous les fils avant le débranchement. Des erreurs de câblage peuvent entraîner un fonctionnement inadéquat et dangereux." "S'assurer que l'appareil fonctionne adéquatement une fois l'entretien terminé.

BLOWERS

WARNING: Label all wires prior to disconnection when servicing controls. Wiring errors can cause improper and dangerous operation. Verify proper operation after servicing.

Dual blowers are provided as standard equipment with this FV-44i Insert. The dual blowers have an air output rating of 190 CFM (in free air). This Insert is designed to operate with the blowers turned OFF or ON. Turning the blower on increases the overall efficiency of this fireplace and aids in distributing and circulating heat to the room this Insert is installed in.

Blower Operation

The remote control system supplied with this appliance can turn the blowers ON or OFF and regulate the speed of the blowers in six (6) steps.

NOTE: In the Normal Thermostat Mode and the SMART Mode, there will be a time delay in blower operation during "heat-up" (5 minutes) and extended blower operation during "cool-down" of unit (12-1/2 minutes).

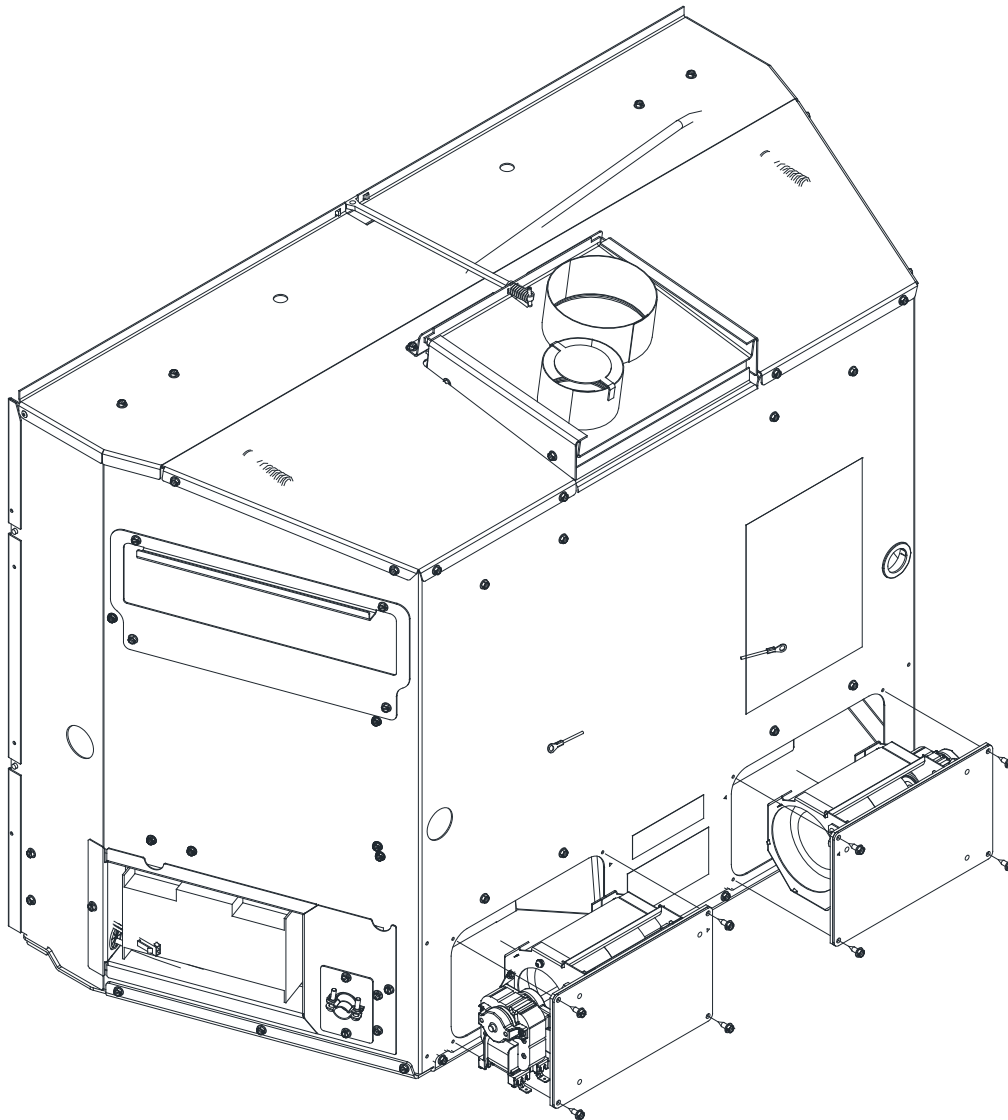

GLASS FRAME REMOVAL

CAUTION: Do not operate the appliance with glass removed, cracked or broken. Replacement of the glass panel should be done by a licensed or qualified service person.

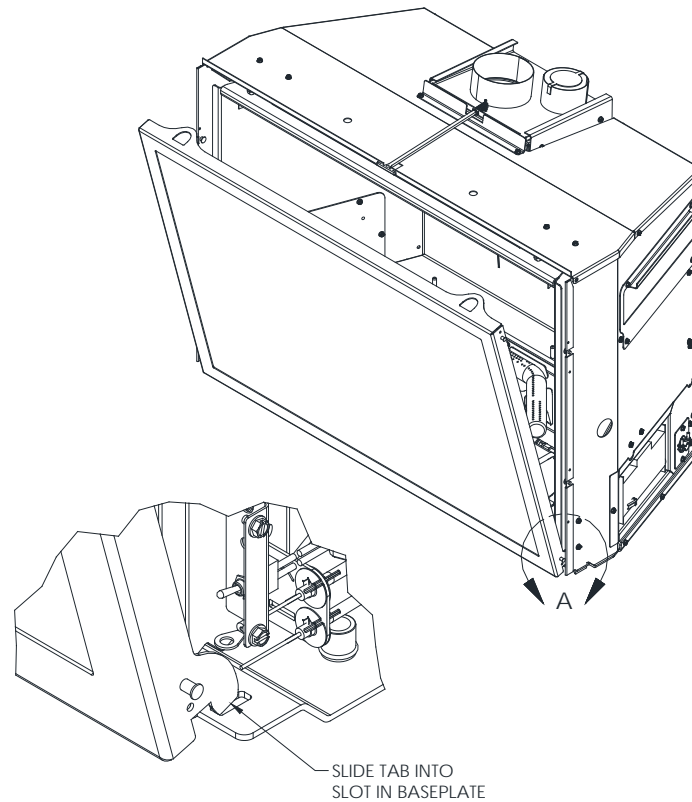

1.) INSERT



2.) PULL

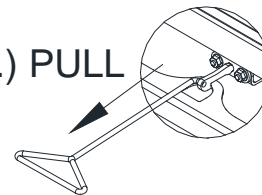

3.) ROTATE

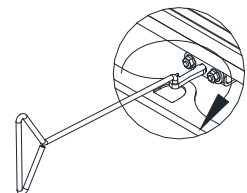

4.) RELEASE

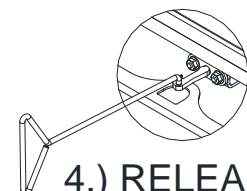

Removing the Glass Frame

1. Insert Glass Latch Tool into the hole in the glass latch (two latches exist at the top of the glass frame).
2. Pull Glass Latch Tool outward about 3/8".
3. Rotate Glass Latch Tool 90 degrees.
4. Release Glass Latch Tool.
5. Remove Glass Latch Tool.

Installing the Glass Frame

Reverse steps 5 to 1, above.

SERVICE PARTS

Valve Assembly

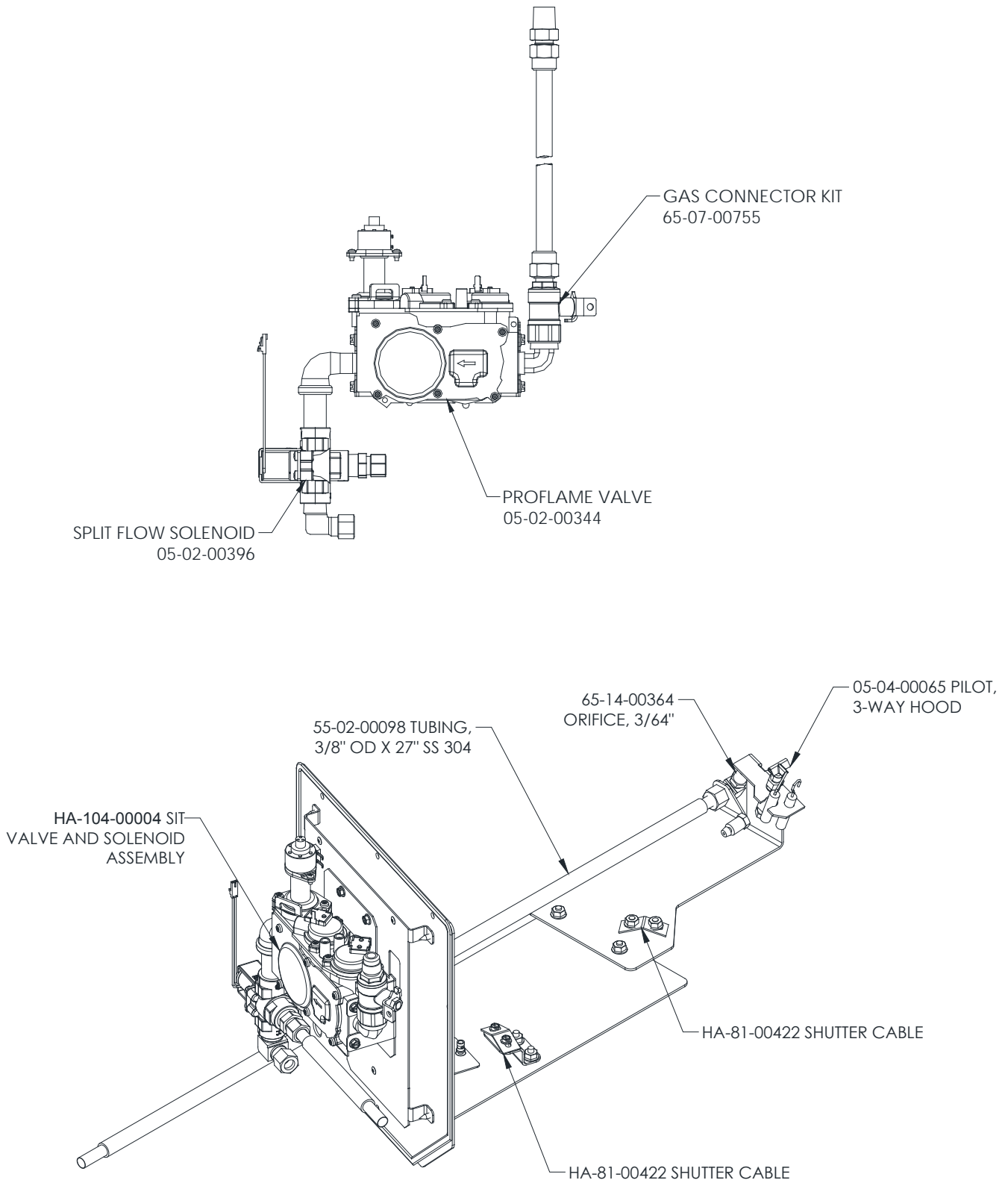

Burner Parts

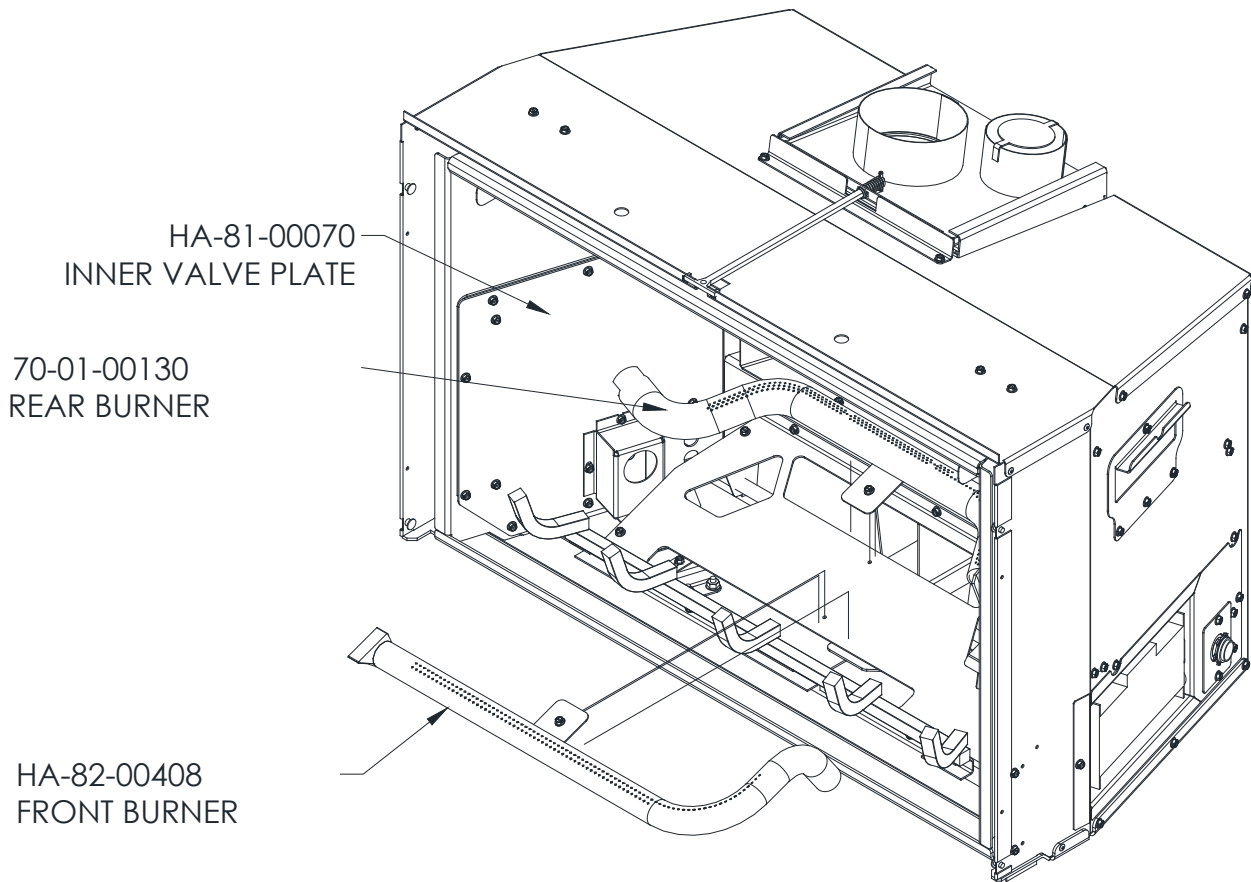

Blower Parts

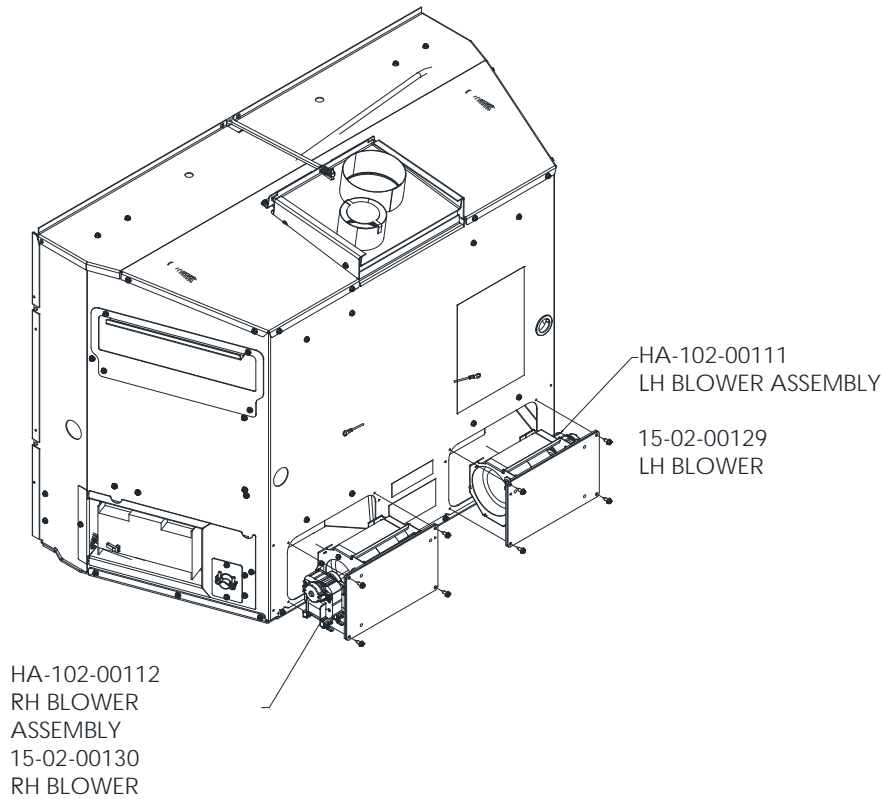

Glass Frame Assembly Repair and Replacement

DO NOT substitute other manufacturer's materials or components.

DO NOT operate unit with cracked, broken or missing glass.

DO NOT abuse the glass door by striking the glass, slamming the door shut, etc

WARNING
Use only authorized parts and materials obtained from Johnson Gas Appliance Company when replacing defective or damaged glass.

WARNING
Do not operate this appliance with the glass removed, cracked or broken. Glass should be replaced by a licensed or qualified person.

TO REPLACE DAMAGED GLASS

1. Bend Glass Retainer Tabs up 90 degrees. Four tabs hold down the glass and gasket assembly.
2. Remove the damaged glass and gasket material. Clean the inner surface of the glass frame.
3. Assemble new gasket on glass edge starting with the bottom left corner. The adhesive on the gasket should make contact with the glass surface. Use tracer lines in gasket to determine where the glass should sit on the gasket surface.
4. Place glass and gasket assembly in glass frame and carefully bend down glass retainer tabs. Extra glass retainer tabs are provided should any originally used tabs break off.

The glass frame assembly and its individual components are available through Johnson Gas Appliance Company. Contact your dealer for more detailed ordering information.

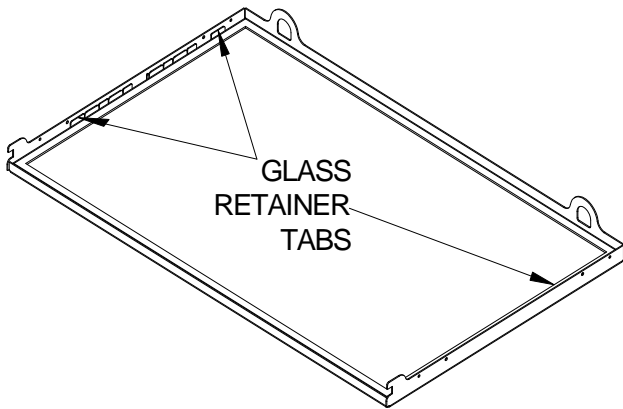

GLASS FRAME ASSEMBLY # HA-82-00403 REPLACEMENT PARTS LIST		
ITEM	PART NUMBER	DESCRIPTION
1	HA-82-00419	FRAME, WELDMENT, GLASS, FV33i
2	65-02-00103	GASKET, TADPOLE, 5/8" BULB, 1" TAIL
3	65-06-01272	GLASS, CERAMIC, FV33i

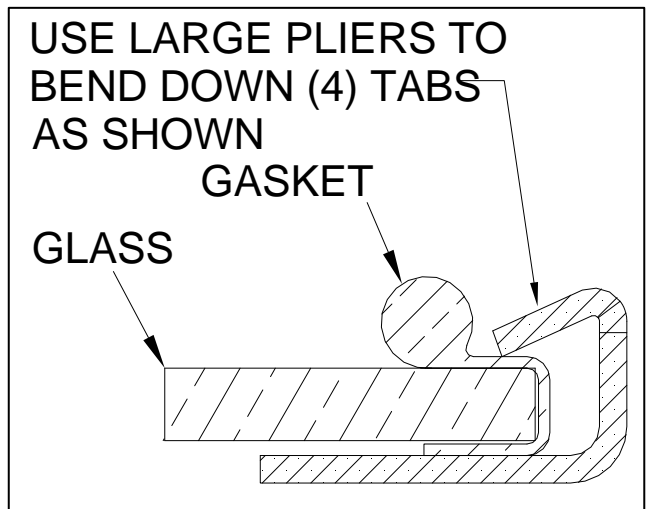
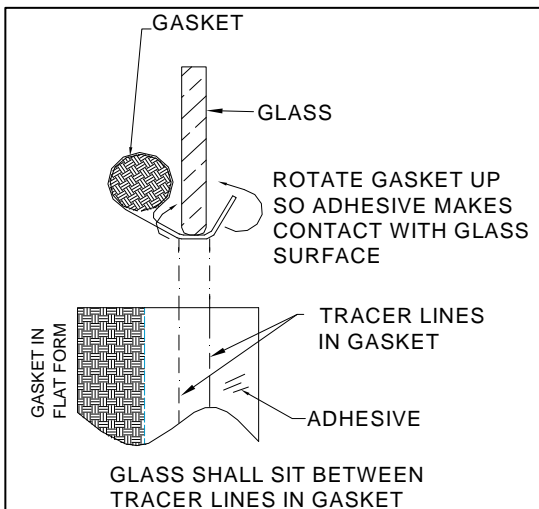

MENDOTA WARRANTY & SERVICE FORM

As a part of Mendota's on-going program of customer satisfaction, this form verifies proper installation and operation. It is important as a reference for future service. It insures long life and trouble-free operation of Mendota fireplaces & stoves and qualifies the owner for Mendota's lifetime limited warranty. Owner should sign Form when completed. Optionally, please register at our website at: <http://mendotahearth.com/gas-fireplace-and-stove-registration.php>

HOME OWNER: _____ DEALER: _____
ADDRESS: _____ ADDRESS: _____
CITY/STATE/ZIP: _____ CITY/STATE/ZIP: _____
SIGNATURE: _____ PHONE: _____
MODEL #: _____ SERIAL #: _____ DATE INSTALLED: _____
GAS _____ NAT or _____ L.P.

Mendota Fireplace Inserts are sophisticated, hi-tech gas appliances. All installation and operating instructions must be carefully followed. This Insert must be installed and serviced by a qualified Mendota approved service person.

Installer must perform and note functions listed below.
--

- APPROVED VENT PIPES AND VENT CAP INSTALLED - Per Manual and manufacturer's specifications
- CHECK FOR PROPER CLEARANCES TO COMBUSTIBLES - Per pipe manufacturer's specifications
- INSTALL PROPER SIZE GAS LINES - CHECK FOR GAS LEAKS - Per Manual
- CHECK FOR CORRECT GAS PRESSURE AT SUPPLY INLET
 - a. 5 Inches Water Column Minimum - Nat. Gas, Measured Inlet Pressure NG _____
 - b. 11 Inches Water Column Minimum - L.P. Gas, Measured Inlet Pressure LPG _____
- CYCLE BURNERS ON/OFF FOR PROMPT IGNITION - Per "LIGHTING INSTRUCTIONS"
Burner must light IMMEDIATELY - Flame must travel promptly around "curve" & light burner.
- INSTALL LOGS AND ADJUST FLAME - Per Manual
Proper pilot flame impingement on pilot sensor rod & burner - Air shutter opening: 1/8" - 1/4" Nat. Gas - 1/2" LP
- BRIEF OWNER ON OPERATION AND MAINTENANCE OF UNIT
 - Light Pilot
 - Operate Burner
 - Explain blower "delay" operation

CUT OUT PAGE AND MAIL TO: JOHNSON GAS APPLIANCE CO., 520 E AVE. N.W. , CEDAR RAPIDS, IOWA 52405

WARRANTY REGISTRATION INFORMATION

Name _____
Address _____
City _____ State ____ Zip _____
Dealer (Place of Purchase) _____
City _____ State ____ Zip _____
Date of Purchase _____ Serial Number _____
Purchaser's Signature _____

OR REGISTER YOUR NEW PRODUCT AT: <http://mendotahearth.com/gas-fireplace-and-stove-registration.php>

TAPE SHUT

**JOHNSON GAS APPLIANCE COMPANY
520 E AVENUE N.W.
CEDAR RAPIDS, IA 52405**



MENDOTA LIFETIME WARRANTY

Mendota Fireplaces Division of Johnson Gas Appliance Company, 520 E Avenue N.W. Cedar Rapids, Iowa 52405, extends this Extended Protection and Limited Warranty to the original purchaser, with limits and when only used under normal home conditions. Units employed for commercial use are do not qualify for the Extended Lifetime Warranty.

Standard Warranty:

Johnson gas appliance co., Mendota division, warrants that your new Mendota fireplace and all its components are free from manufacturing and material defects for a period of one year from the date of installation. Subject to proof of purchase and the conditions and limitations outlined, below.

Extended Lifetime Warranty:

The main burner assemblies, heat exchanger, combustion chamber and outer skins and shields are warranted for the lifetime of the original owner, subject to proof of purchase and the conditions and limitations outlined, below.

1. This Mendota Fireplace must be installed & serviced by a competent, authorized service contractor. It must be installed and operated at all times in accordance with the installation and operating instructions furnished with the Fireplace. All adjustments to logs, coals and burner must be made by an authorized Mendota person. Any alteration, willful abuse, accident or misuse of the product shall nullify this warranty. This warranty does not cover gas flow train components, electrical components, ceramic glass or logs or firebox lining panel breakage.
2. This limited warranty does not cover the cost of service calls, the cost of labor to remove or install parts covered by this limited warranty, freight or other transportation expenses which may be incurred in connection with obtaining performances under this limited warranty. The remedy for damages as the result of any defects in this product which have been warranted herein is limited to replacement parts and does not include any incidental, indirect or consequential damages or expenses sustained in connection with the product, including damages to property, except as provided by law.
3. This warranty is non-transferable and is made to the original retail purchaser, provided the purchase was made through an authorized Mendota dealer.
4. Mendota is not responsible for any damage to or malfunction of the Fireplace unless caused by a defect in material or workmanship from normal home use. Damage caused by abuse, improper installation, improper servicing, and installation by unqualified personnel or breach of conditions of this limited warranty will excuse Mendota from performance of any part of this limited warranty. Mendota has the right to investigate and inspect the exact, original Fireplace and entire installation (without any alterations or tampering) in the event a claim is made to determine whether the claimed damage or malfunction was caused by abuse, improper installation or other cause outside this warranty. Mendota is not responsible for any repairs or material purchases that have not received prior written approval from Mendota.

NOTE: Minor warping of certain parts or discoloration of paints are normal and are not considered a defect nor covered by this warranty. Major warping of parts can be caused by over-firing of your Mendota Fireplace. Over-firing above rated nameplate specification is contrary to the manufacturer's instructions and may void this warranty.

5. This warranty may not be extended by our representatives or any third party in any manner. The company neither assumes nor authorizes any third party to assume, on its behalf, any other liabilities with respect to the sale of this Mendota product.
6. Mendota may at its discretion, may fully discharge all obligations of this warranty by refunding the wholesale price of the defective part(s).
7. All other warranties - expressed or implied with respect to the product, its components and accessories, or any obligation/liabilities on the part of the company are hereby expressly excluded. Products made by other manufacturers, sold with the Fireplace or thereafter, are not covered by this limited warranty. The use of unauthorized components will make this warranty null and void.
8. It remains the full responsibility of the owner to operate this appliance within the guidelines provided in the Installation Manual and the Operating Instructions Manual accompanying this appliance. Further, the owner shall bear full responsibility to enforce clearances to combustibles requirements and cautioning others about hot glass surfaces and hot metal surfaces. Owner, by operating this appliance, accepts that this is a heat producing appliance which has glass and steel parts that are hot enough to cause severe burns. Owner accepts that this appliance requires close monitoring of children and vulnerable individuals who are in the vicinity of this appliance when this appliance is in operation. Mendota does not assume or accept any liability claims for burns or other physical or material damages resulting from touching hot glass surfaces and hot metal surfaces that are part of this appliance or other adjacent object such as hearth pads and mantels that may heat up during operation of this appliance.
9. This warranty shall be effective only if the original purchaser of the Mendota appliance is registered with Mendota Division within thirty (30) days of the date of purchase. Such registration or the failure to register shall not be deemed to create any obligation or liability by the manufacturer and this warranty with its conditions and limitations shall be the only procedure for obtaining any rights against the manufacturer and expresses the sole obligation and responsibilities of the manufacturer which are offered to the original purchaser and accepted upon purchase of the appliance.
10. Mendota reserves the right to make changes at any time without notice, in design, material, specifications, prices and the right to discontinue styles and products.



Gas Fireplaces

MENDOTA

NORTH AMERICA'S LUXURY FIREPLACE

Johnson Gas Appliance Company

520 E Avenue N.W.

Cedar Rapids, IA 52405

Website: www.mendotahearth.com

THE MENDOTA FIREPLACE EXPERIENCE