



Gas Stoves



Welcome to the world of Jøtul.  
Or rather to “The spirit of Jøtul”.

“The spirit of Jøtul” is all about a passion for warmth, which has burned brightly since the company began in 1853.

This passion inspires our philosophy “Warmth in every detail” which you can read about on the following pages.

To us heating is much more than physical warmth and cosiness, and we apply this philosophy to every stove and fireplace we create. That is why our products provide more than just warmth and cosiness. They do of course fulfill both of these functions extremely well, but all the products in this catalogue have so much more to offer.

I and everyone else at Jøtul hope that you will appreciate our broad range of stoves and fireplaces.

“The spirit of Jøtul” was first ignited in 1853 in Norway; it now burns brightly throughout the world. We hope that it will kindle and inspire you too.



Erik Moe, President & CEO

experience the spirit of Jøtul

## Contents

|                                |    |
|--------------------------------|----|
| Jøtul's Warmth Philosophy      | 4  |
| Jøtul GF 100 DV II Nordic QT   | 6  |
| Jøtul GF 200 DV II Lillehammer | 8  |
| Jøtul GF 300 DV/BV Allagash    | 10 |
| Jøtul GF 400 DV/BV Sebago      | 12 |
| Jøtul GF 600 DV II Firelight   | 14 |
| JøtulBurner™/Jøtul Heat Fin™   | 16 |
| Gas Vent Guidelines            | 18 |
| Technical Specifications       | 19 |

# Jøtul's Warmth Philosophy

Where most people consider warmth to mean heating and cosiness, experience has taught us there is much more to it than that. In fact, there are six types of warmth: physical warmth and atmospheric warmth, in addition to visual, convenient, durable and sustainable warmth.

We combine our warmth philosophy, "Warmth in every detail," with a rich tradition of fine craftsmanship. In doing so we design cast iron stoves and fireplaces that create the ultimate warmth experience.

## Physical warmth

To us, heating is not about creating the highest temperature, it is about creating the most comfortable temperature. Due to an optimum combination of convected and radiated heat our products can provide the most comfortable heat, in the most efficient manner. Furthermore, our clean burn technology ensures that practically all the particles and gasses in the smoke are burned.



## Atmospheric warmth

Nothing creates an intimate atmosphere quite like a gently crackling fire. And nothing calms you quite like the image of a flame dancing hypnotically on a glowing log. We have always believed in the seductive powers of the visible flame. For this reason, we have developed pioneering flame technology to achieve the perfect flame at all times.



## Visual warmth

The atmosphere produced by a stove or fireplace is largely dependent on the aesthetic message it sends out. We aim to create a lasting impression in the home and follow our own "design for generations" ideal to give our stoves and fireplaces a timeless appeal. We collaborate with acclaimed design houses in order to design award-winning stoves and fireplaces that outlive trends and retain their timeless beauty for decades.

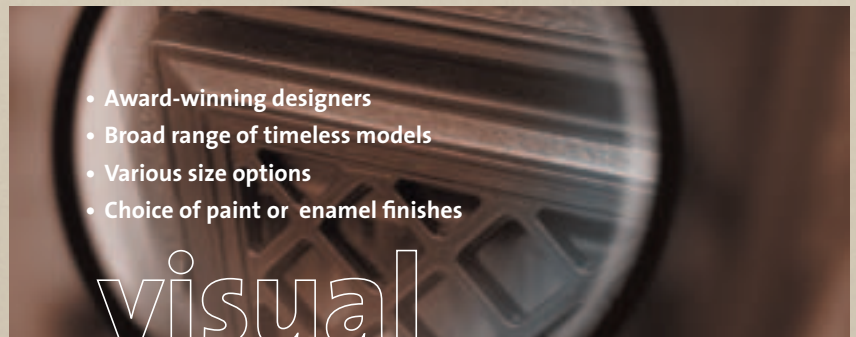

- 
- Easy to operate
  - Problem-free maintenance
  - Wipe-clean glass and enamel surfaces
  - Simple installation and part replacement

# convenient

- 
- Dependable cast iron durability
  - 10-year manufacturing guarantee
  - Minimum 10-year part availability
  - Cast iron heritage since 1853

# durable

- 
- Minimal smoke emissions
  - Recycled materials
  - Clean burn products

# sustainable

#### Convenient warmth

We put an enormous amount of effort into our hearth products so our customers don't have to. The hearth is the center-piece of the home – it is an essential part of everyday life – and for this reason it should represent total functionality. Everything about a Jøtul product is geared towards our customers' convenience: it is easy to install, easy to use, easy to clean and easy to maintain. Life is already complicated enough, so we make its pleasures a little easier to enjoy.

#### Durable warmth

Owning a Jøtul stove or fireplace is a lasting experience. Since 1853 we have employed the finest handcrafting techniques in order to provide our customers with long-lasting, durable warmth. Warmth they can trust. Because where fire is involved, safety and security are vital. Cast iron delivers the highest standard of strength and durability. As one of the world's oldest cast iron stove and fireplace manufacturers, no company delivers a longer lasting promise of quality.

#### Sustainable warmth

Our understanding of warmth enables us to create the ultimate experience of warmth. All the cast iron we use is recycled. And by relying mostly on hydroelectric power to smelt recycled iron, we keep polluting emissions to an absolute minimum. Furthermore, our clean burn technology ensures that our products boast the most efficient use of energy which also reduces the volumes of particles emitted locally. This means our customers can light their hearth products with minimal effect on the environment.

# Jøtul GF 100 DV II Nordic QT

## Direct Vent Gas Stove

Utilizing a traditional Norwegian sweater pattern design, world-renowned Red House Design in conjunction with our well-regarded team of in-house design engineers, developed the first freestanding zero clearance high efficiency gas stove - the Jøtul GF 100 DV II Nordic QT. Designed with easy, low cost installations in mind, this stove is perfect for your bedroom, bathroom or any other smaller living area. Just as important, the Jøtul GF 100 DV II Nordic QT comes equipped with Jøtul's revolutionary cast iron and stainless steel burner, the JøtulBurner™. Popular options include: wall thermostat, mobile home approved floor bracket kit, variable speed blower fan kit, antique brick panel kit, remote control, a choice of enamel colors and our Jøtul Iron™ or Classic Matte Black Paint.



JøtulBurner™

### Options

*Antique brick panel kit (molded from real brick)*

*Wall thermostat*

*Remote control*

*Variable speed blower fan kit*

*Floor bracket kit (for mobile home installations)*

*Choice of six porcelain enamel colors*

*Jøtul Iron™ or Classic Matte Black Paint*

*Leg leveler kit*



### Features

Revolutionary new JøtulBurner™ delivers unsurpassed gas burner technology and flame picture realism (Patent # 7004751)

50% heat control turn down

Handcrafted ceramic fiber log set burns with the glowing warmth of a real wood fire

Durable, furniture quality cast iron construction

No electricity required to operate

Zero clearance rear vent capability

Ability to corner vent without snorkel or tall cap

Large fire viewing area

ON/OFF Thermostat switch

Natural convection for increased air circulation

Vent restrictors included for vertical terminations

Conversion kit included for use with propane gas

Mobile home approved

5 year limited warranty

|                                        |                                                                                     |
|----------------------------------------|-------------------------------------------------------------------------------------|
| <i>Classic Matte Black Paint</i>       |  |
| <i>Jøtul Iron™ Paint</i>               |  |
| <i>Forest Green Porcelain Enamel</i>   |  |
| <i>Jøtul Iron™ Porcelain Enamel</i>    |  |
| <i>Blue/Black Porcelain Enamel</i>     |  |
| <i>Ivory Porcelain Enamel</i>          |  |
| <i>Blue Majolica Porcelain Enamel</i>  |  |
| <i>Brown Majolica Porcelain Enamel</i> |  |



Jøtul GF 100 DV II Nordic QT

*Jøtul GF 100 DV II Nordic QT shown here in Ivory Porcelain Enamel and optional antique brick panel kit*

# Jøtul GF 200 DV II Lillehammer

## Direct Vent Gas Stove

Designed in collaboration with world-renowned Red House Design and our well-regarded in-house design engineering staff, the Jøtul GF 200 DV II Lillehammer brings into your home a touch of Scandinavian charm and warmth reminiscent of the 1994 Winter Olympics in Lillehammer, Norway. We challenge you to find another stove among the competition possessing the same crisp lines and sharp features that define world class craftsmanship and foundry capabilities. Popular options include: variable speed blower fan kit, antique brick panel kit (molded from real brick), screen for open door fire viewing, floor bracket kit (for mobile home installations), wall thermostat, remote control, a choice of enamel colors and our Jøtul Iron™ or Classic Matte Black Paint.



JøtulBurner™

### Options

Antique brick panel kit (molded from real brick)

Wall thermostat

Variable speed blower fan kit

Screen for open door fire viewing

Remote control

Floor bracket kit (for mobile home installations)

Choice of plinth or long legs (8")

Choice of six porcelain enamel colors

Jøtul Iron™ or Classic Matte Black Paint

Leg leveler kit



### Features

Revolutionary new JøtulBurner™ delivers unsurpassed gas burner technology and flame picture realism (Patent #7004751)

50% heat control turn down

Durable, furniture quality cast iron construction

ON/OFF thermostat switch

Handcrafted ceramic fiber log set burns with the glowing warmth of a real wood fire

Ability to corner vent without snorkel or tall cap

Conversion kit included for use with propane gas

No electricity required; easy-to-operate ignition system

Zero clearance rear vent capability

Natural convection for increased air circulation

Vent restrictors included for vertical terminations

Mobile home approved

5 year limited warranty

|                                 |                                                                                     |
|---------------------------------|-------------------------------------------------------------------------------------|
| Classic Matte Black Paint       |  |
| Jøtul Iron™ Paint               |  |
| Forest Green Porcelain Enamel   |  |
| Jøtul Iron™ Porcelain Enamel    |  |
| Blue/Black Porcelain Enamel     |  |
| Ivory Porcelain Enamel          |  |
| Blue Majolica Porcelain Enamel  |  |
| Brown Majolica Porcelain Enamel |  |





*Jøtul GF 200 DV II Lillehammer shown here in Majolica Blue Porcelain Enamel, optional antique brick panel kit, and fire screen*

*Jøtul GF 200 DV II Lillehammer*

# Jøtul GF 300 DV/BV Allagash



*JøtulBurner™*

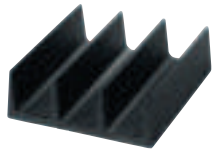

*Jøtul Heat Fin™*

## Direct Vent or B-vent Gas Stove

As rugged as the wilderness waterway that bears its name, world-renowned Red House Design and our team of in-house design engineers made sure that our Jøtul GF 300 DV/BV Allagash presents the perfect union of high efficiency and cast iron beauty. Its classic lines and Gothic arch double doors frame a hand-crafted log set, flame and glowing embers with a realism unrivaled in the hearth industry. Fueled by the quiet durability of our revolutionary new cast iron and stainless steel burner - the JøtulBurner™ - this stove is the best-selling gas stove in the long history of Jøtul. Popular options include: antique brick panel kit, remote control, fire screen for open door viewing, short leg kit for fireplace installations, a choice enamel colors and Jøtul Iron™ or Classic Matte Black Paint.

### Options

*Antique brick panel kit (molded from real brick)*

*Wall thermostat*

*Remote control*

*Floor bracket kit (for mobile home installations)*

*Top plate filler (for B-vent rear exit installations only)*

*Variable speed blower fan kit*

*Screen for open door fire viewing*

*Short leg kit for fireplace installations (reduces height by 2 1/4")*

*Choice of five porcelain enamel colors*

*Jøtul Iron™ or Classic Matte Black Paint*

*Leg leveler kit*



### Features

Revolutionary new JøtulBurner™ delivers unsurpassed gas burner technology and flame picture realism (Patent #7004751)

Handcrafted ceramic fiber log set burns with the glowing warmth of a real wood fire

Standard reversible flue collar for top or rear exit capability

Large fire viewing area with open door capability – an industry pioneer!

Durable, furniture quality cast iron construction

ON/OFF Thermostat switch

Natural convection for increased air circulation

Vent restrictors included for vertical terminations (Direct Vent only)







Jøtul Heat Fin™ technology means great heating capacity with a minimum of heat loss

Pre-wired for blower fan kit

No electricity required to operate stove

Conversion kit included for use with propane gas

5 year limited warranty

|                                        |                                                                                     |
|----------------------------------------|-------------------------------------------------------------------------------------|
| <i>Classic Matte Black Paint</i>       |  |
| <i>Jøtul Iron™ Paint</i>               |  |
| <i>Jøtul Iron™ Porcelain Enamel</i>    |  |
| <i>Blue/Black Porcelain Enamel</i>     |  |
| <i>Ivory Porcelain Enamel</i>          |  |
| <i>Blue Majolica Porcelain Enamel</i>  |  |
| <i>Brown Majolica Porcelain Enamel</i> |  |



*Jøtul GF 300 DV Allagash shown here in Blue/Black Porcelain Enamel with optional antique brick panel kit and fire screen*

*Jøtul GF 300 DV/BV Allagash*

# Jøtul GF 400 DV/BV Sebago



*JøtulBurner™*

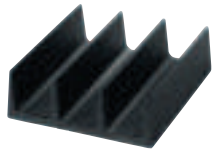

*Jøtul Heat Fin™*

## Direct Vent or B-Vent Gas Stove

Red House Design, in collaboration with our well-regarded in-house design engineers, created this Vesta Design and Technology Award finalist with beauty and high efficiency operation in mind. With its nautical theme that takes your mind off to sea from the shores of Norway or Maine, the Jøtul GF 400 DV or BV Sebago is our latest addition to the Jøtul Family. This stove incorporates our innovative new cast iron and stainless steel JøtulBurner™ - a revolution in gas flame technology. With a hand crafted log set and double door design, this stove demonstrates why Jøtul is widely recognized as the cast iron leader in quality and craftsmanship. Popular options include: antique brick panel kit, screen for open door fire-viewing, remote control and a choice of colors.

### Options

*Antique brick panel kit (molded from real brick)*

*Wall thermostat*

*Remote control*

*Floor bracket kit (for mobile home installations)*

*Variable speed blower fan kit*

*Screen for open door fire viewing*

*Short leg kit for fireplace installations*

*(reduces height by 2 1/4")*

*Choice of six porcelain enamel colors*

*Jøtul Iron™ or Classic Matte Black Paint*

*Leg leveler kit*



### Features

Revolutionary new JøtulBurner™ delivers unsurpassed gas burner technology and flame picture realism (Patent #7004751)

Handcrafted ceramic fiber log set burns with the glowing warmth of a real wood fire

Standard reversible flue collar for top or rear exit capability

Large fire viewing area with open door capability – an industry pioneer!

Durable, furniture quality cast iron construction

ON/OFF Thermostat switch

Vent restrictors included for vertical terminations

Jøtul Heat Fin™ technology means great heating capacity with a minimum of heat loss

Pre-wired for blower fan kit

No electricity required to operate stove

Conversion kit included for use with propane gas

5 year limited warranty

|                                        |                                                                                     |
|----------------------------------------|-------------------------------------------------------------------------------------|
| <i>Classic Matte Black Paint</i>       |  |
| <i>Jøtul Iron™ Paint</i>               |  |
| <i>Forest Green Porcelain Enamel</i>   |  |
| <i>Jøtul Iron™ Porcelain Enamel</i>    |  |
| <i>Blue/Black Porcelain Enamel</i>     |  |
| <i>Ivory Porcelain Enamel</i>          |  |
| <i>Blue Majolica Porcelain Enamel</i>  |  |
| <i>Brown Majolica Porcelain Enamel</i> |  |



Jøtul GF 400 DV/BV Sebago

*Jøtul GF 400 DV Sebago shown here in Majolica Brown Porcelain Enamel with optional antique brick panel kit and fire screen*

# Jøtul GF 600 DV II Firelight

## Direct Vent Gas Stove

A descendent of our signature Jøtul F 600 Firelight CB wood stove, the Jøtul GF 600 DV II Firelight provides the same double door, open fire viewing and classic design that put Jøtul on the wood burning map in North America. Without any doubt, this stove has an unparalleled flame picture fueled by Jøtul's revolutionary cast iron and stainless steel burner, the JøtulBurner™. With its 50% heat control turn down capability, the Jøtul GF 600 DV II Firelight fulfills the heat requirements of a variety of living spaces and can be used as a primary heat source. Popular options include: screen for open door fire viewing, antique brick panel kit, remote control, variable speed blower fan kit, a choice of six enamel colors and Jøtul Iron™ or Classic Matte Black Paint.



JøtulBurner™

### Options

*Screen for open door fire viewing*

*Antique brick panel kit (molded from real brick)*

*Wall thermostat*

*Remote control*

*Floor bracket kit (for mobile home installations)*

*Variable speed blower fan kit*

*Choice of six porcelain enamel colors*

*Jøtul Iron™ or Matte Black Paint*



### Features

Revolutionary new JøtulBurner™ delivers unsurpassed gas burner technology and flame picture realism (Patent #7004751)

50% heat control turn down

Largest fire viewing area available in a freestanding gas stove with open door fire viewing

Hand-crafted ceramic fiber log set burns with the glowing warmth of a real wood fire

Conversion kit included for use with propane gas

No electricity required; easy-to-operate ignition system

ON/OFF Thermostat switch

Standard reversible flue for top or rear exit capability

Vent restrictors included for vertical terminations

Mobile home approved

5 year limited warranty

|                                 |                                                                                     |
|---------------------------------|-------------------------------------------------------------------------------------|
| Classic Matte Black Paint       |  |
| Jøtul Iron™ Paint               |  |
| Forest Green Porcelain Enamel   |  |
| Jøtul Iron™ Porcelain Enamel    |  |
| Blue/Black Porcelain Enamel     |  |
| Ivory Porcelain Enamel          |  |
| Blue Majolica Porcelain Enamel  |  |
| Brown Majolica Porcelain Enamel |  |



Jøtul GF 600 DV II Firelight

*Jøtul GF 600 DV II Firelight shown here in Blue / Black Porcelain Enamel with optional antique brick panel kit and fire screen*

# JøtulBurner™/Heat Fin™ Technology

This cutaway view of the Jøtul GF 300 DV Allagash illustrates the air flow through a direct vent system and also how the fire's heat is transferred into your home. Fresh air enters through the outer vent pipe and is directed to the bottom of the firebox to mix with gas inside and above the JøtulBurner™ (Patent #7004751).

Gas enters the burner through a control valve, mixes with combustion air and passes through the burner porting where it ignites, creating a realistic "wood-burning" flame. Exhaust gas exits out of the system through the inner vent pipe.

All Jøtul gas stoves deliver heat to your home in two ways; radiant and convection air. Radiant heat is given off through the large front glass panel and off of the cast iron plates of the stove itself. Convection heat is produced by air that is heated as it flows around the firebox and over the Jøtul Heat Fins™ at the top of the firebox, before passing through the expansive latticework of the top plate. An optional blower can be added to aid the convection process.

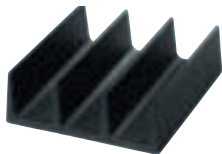

*Jøtul Heat Fin™*

## **Jøtul Heat Fin™**

Jøtul's patented Heat Fin™ technology allows for exceptional heat transference. Made of quality Jøtul materials, the fins create natural heat channels that extract heat from the appliance and into your home.



*JøtulBurner™*

## **JøtulBurner™ (patent #7004751)**

The JøtulBurner™ is constructed of a quality cast iron base mated to a heavy-grade stainless steel porting plate. Our custom machine process "crimps" these parts together allowing the top to "float" on the base, thereby alleviating stress and providing great durability.



- Incoming air
- Gas
- Exhaust
- Convection air (heat)



# Gas Vent Guidelines

## Direct Vent Systems

A direct vent gas appliance is a closed combustion system that takes its combustion air from outside the home. Using either a co-axial pipe (a pipe within a pipe) or a co-linear system to both take air in for combustion and exhaust products of combustion.



## Co-axial Vent

A co-axial vent consists of a smaller pipe within a larger pipe, most commonly a 4-inch pipe inside a 6 5/8 inch pipe. This type of venting pipe is used when the venting runs horizontally and passes through an outside wall, or vertically to penetrate the roof. A specific termination cap is used that separates exhaust gases from the incoming combustion air.

## Co-linear Vent

A co-linear venting system is used for direct vent gas fireplace inserts and freestanding gas stoves when installed in front of existing masonry fireplaces. This venting system consists of two 3-inch flexible liners that are run up a masonry chimney. One liner is used for the air intake and the other for exhaust. The liners are attached to adapters on the unit, run up the flue and then connect to a co-linear adapter on the top of the chimney, to which the direct vent cap is secured. When used with a freestanding stove, a co-linear adapter is also attached to the stove to convert the co-axial pipe to the co-linear venting system.

## B-Vent Systems

A B-vent or natural draft system is often vented into masonry or class A chimney system. Stoves using this type of venting use room air for combustion and exhaust the products of combustion into a chimney. When using a masonry chimney, a 4-inch aluminum gas liner must be installed.



### Jøtul GF 100 DV II Nordic QT

Page 6

#### Venting Options & Specifications

|                               |                                        |
|-------------------------------|----------------------------------------|
| Venting                       | Direct Vent                            |
| Heating Capacity <sup>1</sup> | Up to 600 sq. ft.                      |
| Min/Max Heat Input (BTU/hr)   | 9,900-17,000 (NG)<br>8,700-16,000 (LP) |
| Efficiency <sup>3</sup>       | up to 87% Steady State (A.F.U.E. 73%)  |

|                          |               |
|--------------------------|---------------|
| Safety Features          | Sealed System |
| Optional Blower          | Yes           |
| Optional Wall Thermostat | Yes           |
| Optional Remote control  | Yes           |

#### Dimensions

|                           |                                                    |
|---------------------------|----------------------------------------------------|
| Height                    | 22 1/4"                                            |
| Height w/ opt. short legs | n/a                                                |
| Width                     | 21"                                                |
| Depth <sup>2</sup>        | 16 3/4"                                            |
| Weight                    | 150 lbs.                                           |
| Venting                   | Simpson DuraVent GS/<br>AmeriVent/Security/Selkirk |

#### Clearances

|                    |                     |
|--------------------|---------------------|
| Rear               | 0" (zero clearance) |
| Side               | 3"                  |
| Corner             | 2"                  |
| 9 1/2" deep mantel | 25"                 |

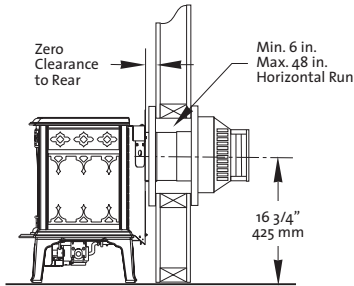

### Jøtul GF 200 DV II Lillehammer

Page 8

|                               |                                         |
|-------------------------------|-----------------------------------------|
| Venting                       | Direct Vent                             |
| Heating Capacity <sup>1</sup> | Up to 800 sq. ft.                       |
| Min/Max Heat Input (BTU/hr)   | 11,400-20,000 (NG)<br>8,440-18,000 (LP) |
| Efficiency <sup>3</sup>       | up to 87% Steady State (A.F.U.E. 73%)   |

|                          |               |
|--------------------------|---------------|
| Safety Features          | Sealed System |
| Optional Blower          | Yes           |
| Optional Wall Thermostat | Yes           |
| Optional Remote control  | Yes           |

#### Dimensions

|                           |                                                    |
|---------------------------|----------------------------------------------------|
| Height                    | 24 3/4"                                            |
| Height w/ opt. short legs | n/a                                                |
| Width                     | 22 3/4"                                            |
| Depth <sup>2</sup>        | 18 1/2"                                            |
| Weight                    | 190 lbs.                                           |
| Venting                   | Simpson DuraVent GS/<br>AmeriVent/Security/Selkirk |

#### Clearances

|                    |                     |
|--------------------|---------------------|
| Rear               | 0" (zero clearance) |
| Side               | 3"                  |
| Corner             | 2"                  |
| 9 1/2" deep mantel | 27 1/4"             |

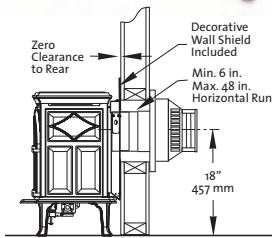

#### Leg Styles & Sizes

<sup>1</sup> Heating Capacity will vary depending on the design of the home, climate, operation and venting configuration.

<sup>2</sup> Depth dimension includes ashlip and flue collar.

<sup>3</sup> With maximum vent configuration

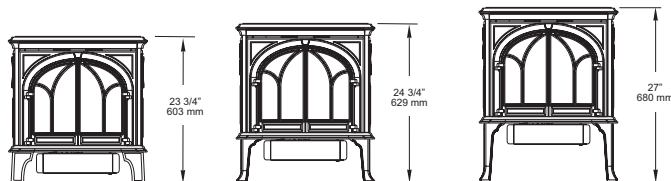

Technical Specifications



## Jøtul GF 300 BV Allagash

Page 10

### Venting Options & Specifications

|                               |                                          |
|-------------------------------|------------------------------------------|
| Venting                       | B-Vent                                   |
| Heating Capacity <sup>1</sup> | Up to 1,300 sq.ft.                       |
| Min/Max Heat Input (BTU/hr)   | 15,000-26,000 (NG)<br>13,500-26,000 (LP) |
| Efficiency <sup>3</sup>       | up to 86% Steady State (A.F.U.E. 73%)    |
| Safety Features               | Sealed System                            |
| Optional Blower               | Yes                                      |
| Optional Wall Thermostat      | Yes                                      |
| Optional Remote control       | Yes                                      |

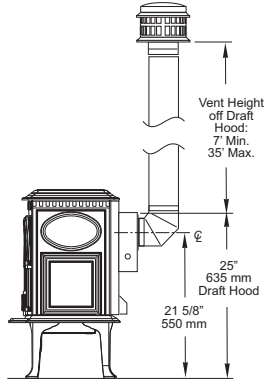

### Dimensions

|                           |           |
|---------------------------|-----------|
| Height                    | 27 3/4"   |
| Height w/ opt. short legs | 25 1/2"   |
| Width                     | 22 3/4"   |
| Depth <sup>2</sup>        | 17 1/2"   |
| Weight                    | 185 lbs.  |
| Venting                   | 4" B-Vent |

### Clearances

|                   |     |
|-------------------|-----|
| Rear              | 2"  |
| Side              | 3"  |
| Corner            | 3"  |
| 11.5" deep mantel | 29" |



## Jøtul GF 300 DV Allagash

Page 10

|                               |                                          |
|-------------------------------|------------------------------------------|
| Venting                       | Direct Vent                              |
| Heating Capacity <sup>1</sup> | Up to 1,300 sq. ft..                     |
| Min/Max Heat Input (BTU/hr)   | 14,000-26,000 (NG)<br>14,000-26,000 (LP) |
| Efficiency <sup>3</sup>       | up to 88% Steady State (A.F.U.E. 72.7%)  |
| Safety Features               | Sealed System                            |
| Optional Blower               | Yes                                      |
| Optional Wall Thermostat      | Yes                                      |
| Optional Remote control       | Yes                                      |

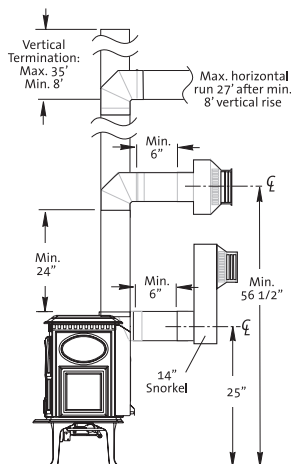

### Dimensions

|                           |                                                    |
|---------------------------|----------------------------------------------------|
| Height                    | 28"                                                |
| Height w/ opt. short legs | 25 3/4"                                            |
| Width                     | 22 3/4"                                            |
| Depth <sup>2</sup>        | 17 1/2"                                            |
| Weight                    | 185 lbs.                                           |
| Venting                   | Simpson DuraVent GS/<br>AmeriVent/Security/Selkirk |

### Clearances

|                 |     |
|-----------------|-----|
| Rear            | 2"  |
| Side            | 3"  |
| Corner          | 2"  |
| 10" deep mantel | 29" |

<sup>1</sup> Heating Capacity will vary depending on the design of the home, climate, elevation, operation and venting configuration.

<sup>2</sup> Depth dimension includes ashlip and flue collar.

<sup>3</sup> With maximum vent configuration



### Jøtul GF 400 BV Seabago

Page 12

#### Venting Options & Specifications

|                               |                                          |
|-------------------------------|------------------------------------------|
| Venting                       | B-Vent                                   |
| Heating Capacity <sup>1</sup> | Up to 2,000 sq. ft.                      |
| Min/Max Heat Input (BTU/hr)   | 22,000-40,000 (NG)<br>20,000-40,000 (LP) |
| Efficiency <sup>3</sup>       | up to 88% Steady State (A.F.U.E. 73.5%)  |

#### Safety Features

|                          |     |
|--------------------------|-----|
| Optional Blower          | Yes |
| Optional Wall Thermostat | Yes |
| Optional Remote control  | Yes |

#### Dimensions

|                           |           |
|---------------------------|-----------|
| Height                    | 28 1/2"   |
| Height w/ opt. short legs | 26 1/4"   |
| Width                     | 26 1/2"   |
| Depth <sup>2</sup>        | 24"       |
| Weight                    | 190 lbs.  |
| Venting                   | 4" B-Vent |

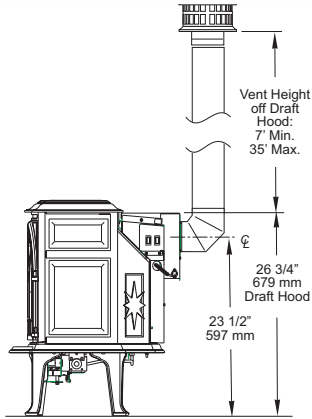

#### Clearances

|                    |         |
|--------------------|---------|
| Rear               | 3"      |
| Side               | 3"      |
| Corner             | 3"      |
| 10.25" deep mantel | 25 1/4" |



### Jøtul GF 400 DV Seabago

Page 12

|                               |                                          |
|-------------------------------|------------------------------------------|
| Venting                       | Direct Vent                              |
| Heating Capacity <sup>1</sup> | Up to 1,500 sq. ft.                      |
| Min/Max Heat Input (BTU/hr)   | 18,000-32,000 (NG)<br>16,000-32,000 (LP) |
| Efficiency <sup>3</sup>       | up to 88% Steady State (A.F.U.E. 73%)    |

#### Safety Features

|                          |     |
|--------------------------|-----|
| Optional Blower          | Yes |
| Optional Wall Thermostat | Yes |
| Optional Remote control  | Yes |

#### Dimensions

|                           |                                                    |
|---------------------------|----------------------------------------------------|
| Height                    | 28 1/2"                                            |
| Height w/ opt. short legs | 26 1/4"                                            |
| Width                     | 26 1/4"                                            |
| Depth <sup>2</sup>        | 26 1/2"                                            |
| Weight                    | 190 lbs.                                           |
| Venting                   | Simpson DuraVent GS/<br>AmeriVent/Security/Selkirk |

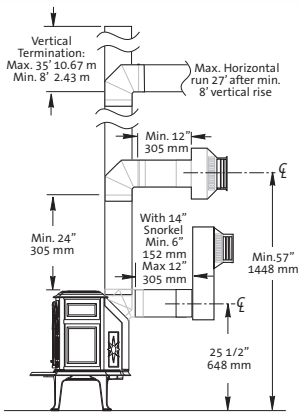

#### Clearances

|                 |     |
|-----------------|-----|
| Rear            | 2"  |
| Side            | 3"  |
| Corner          | 2"  |
| 10" deep mantel | 18" |

<sup>1</sup> Heating Capacity will vary depending on the design of the home, climate, elevation, operation and venting configuration.

<sup>2</sup> Depth dimension includes ashlip and flue collar.

<sup>3</sup> With maximum vent configuration



## Jøtul GF 600 DV II Firelight

Page 14

### Venting Options & Specifications

|                               |                                          |
|-------------------------------|------------------------------------------|
| Venting                       | Direct Vent                              |
| Heating Capacity <sup>1</sup> | Up to 2,000 sq.ft.                       |
| Min/Max Heat Input (BTU/hr)   | 23,900-40,000 (NG)<br>20,300-40,000 (LP) |
| Efficiency <sup>3</sup>       | up to 87% Steady State (A.F.U.E. 73.5%)  |

### Safety Features

|                          |     |
|--------------------------|-----|
| Optional Blower          | Yes |
| Optional Wall Thermostat | Yes |
| Optional Remote control  | Yes |

### Dimensions

|                           |                                                    |
|---------------------------|----------------------------------------------------|
| Height                    | 31"                                                |
| Height w/ opt. short legs | n/a                                                |
| Width                     | 29"                                                |
| Depth <sup>2</sup>        | 24"                                                |
| Weight                    | 260 lbs.                                           |
| Venting                   | Simpson DuraVent GS/AmeriVent/<br>Security/Selkirk |

### Clearances

|                     |     |
|---------------------|-----|
| Rear                | 2"  |
| Side                | 3"  |
| Corner              | 3"  |
| 11 1/2" deep mantel | 11" |

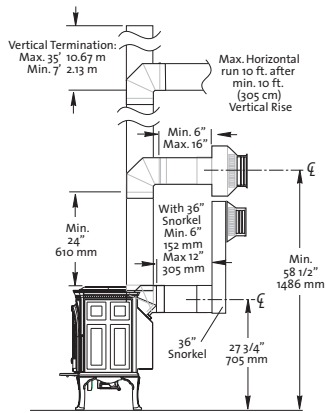

### Hearth Requirements

Jøtul gas stoves cannot be installed directly on carpeting, vinyl, linoleum or Pergo™. If this appliance will be installed on any combustible material other than wood, a floor pad must be installed that is either metal or wood, or a listed hearth pad. This floor protection must extend the full width and depth of the appliance. It is not necessary to remove carpeting, vinyl or linoleum from underneath the floor protection.

<sup>1</sup> Heating Capacity will vary depending on the design of the home, climate, elevation, operation and venting configuration.

<sup>2</sup> Depth dimension includes ashlip and flue collar.

<sup>3</sup> With maximum vent configuration



### **Warranty**

Our 5 year warranty: a cast iron promise of quality. Jøtul guarantees the quality of its cast iron components against any defects in materials or workmanship for five years, subject to the exclusions and limitations noted on our warranty. For complete details, ask your Authorized Jøtul Dealer.

### **Installation**

Specifications and dimensions published in this brochure are intended to be used as guidelines for comparison only. Always consult the owner's manual in planning any installation. Specifications and dimensions are subject to change without notice. Contact local building or fire officials regarding restrictions and installation inspection requirements in your area.

### **Photographs**

Some settings for the photographs are for aesthetic purposes only and may not comply with installation requirements. Materials, specifications, accessories, colors, and models are subject to change without notice. Some models are shown with optional accessories.

BTU ratings are to be used as a guideline only, and do not imply a guarantee of the heating capacity of the unit.



Ask your authorized Jøtul Dealer about our full line of cast iron wood and gas stoves, inserts and fireplaces.



Jøtul North America  
55 Hutcherson Drive  
Gorham, Maine 04038

[www.jotul.us](http://www.jotul.us)

*Jøtul has a policy of constant  
improvement and upgrading.  
Products therefore may differ in  
specification, design, material or  
dimensions at any time  
without prior notice.*

Printed in U.S.A.  
August 2007

Gas Stoves

**JØTUL®**